

Session 17524

z/VM Virtual Switch: The Basics

Alan Altmark

Senior Managing z/VM Consultant

IBM Systems Lab Services



SHARE is an independent volunteer-run information technology association that provides **education, professional networking and industry influence.**

Copyright (c) 2015 by SHARE Inc.  Except where otherwise noted, this work is licensed under <http://creativecommons.org/licenses/by-nc-sa/3.0/>



Note

References to IBM products, programs, or services do not imply that IBM intends to make these available in all countries in which IBM operates. Any reference to an IBM product, program, or service is not intended to state or imply that only IBM's product, program, or service may be used. Any functionally equivalent product, program, or service that does not infringe on any of the intellectual property rights of IBM may be used instead. The evaluation and verification of operation in conjunction with other products, except those expressly designed by IBM, are the responsibility of the user.

IBM, the IBM logo, and ibm.com are trademarks or registered trademarks of International Business Machines Corp., registered in many jurisdictions worldwide. Other product and service names might be trademarks of IBM or other companies. A current list of IBM trademarks is available on the Web at "Copyright and trademark information" at www.ibm.com/legal/copytrade.shtml.

Topics

- Overview
- Multi-zone Networks
- Virtual Switch
- Virtual NIC

Multi-Zone Network

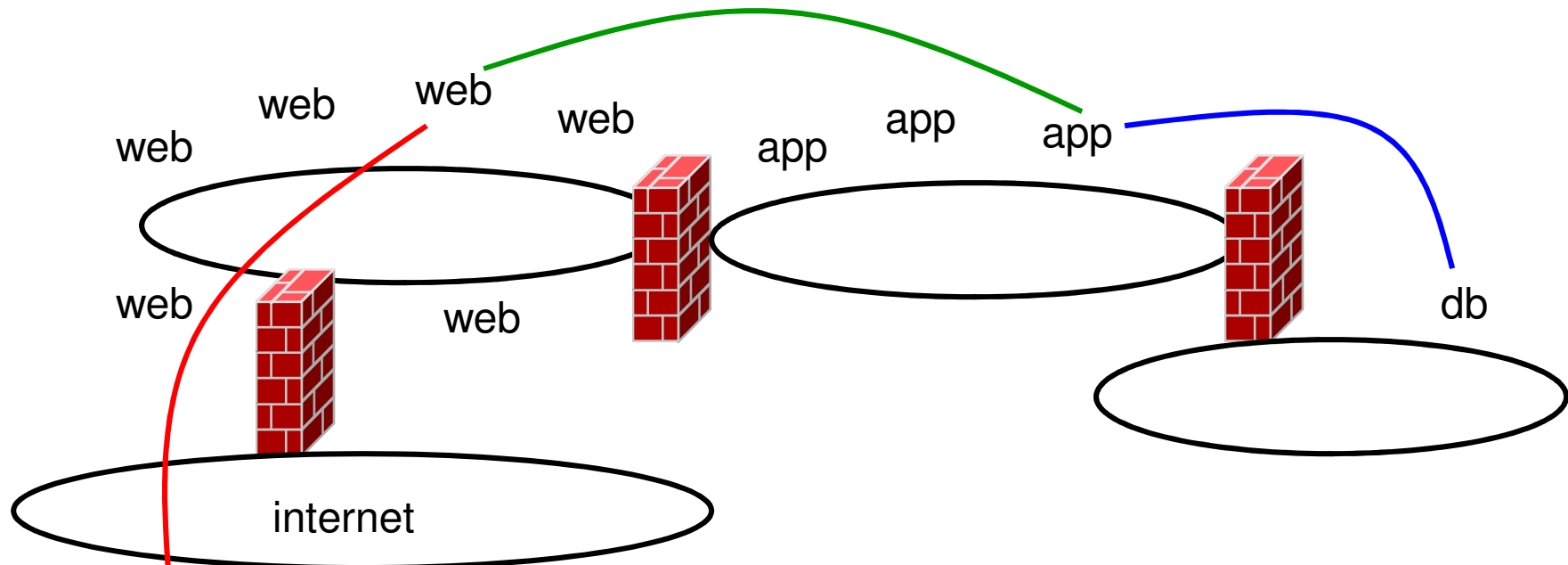

A typical 3-tier application

Multi-zone Network on System z with outboard firewall / router

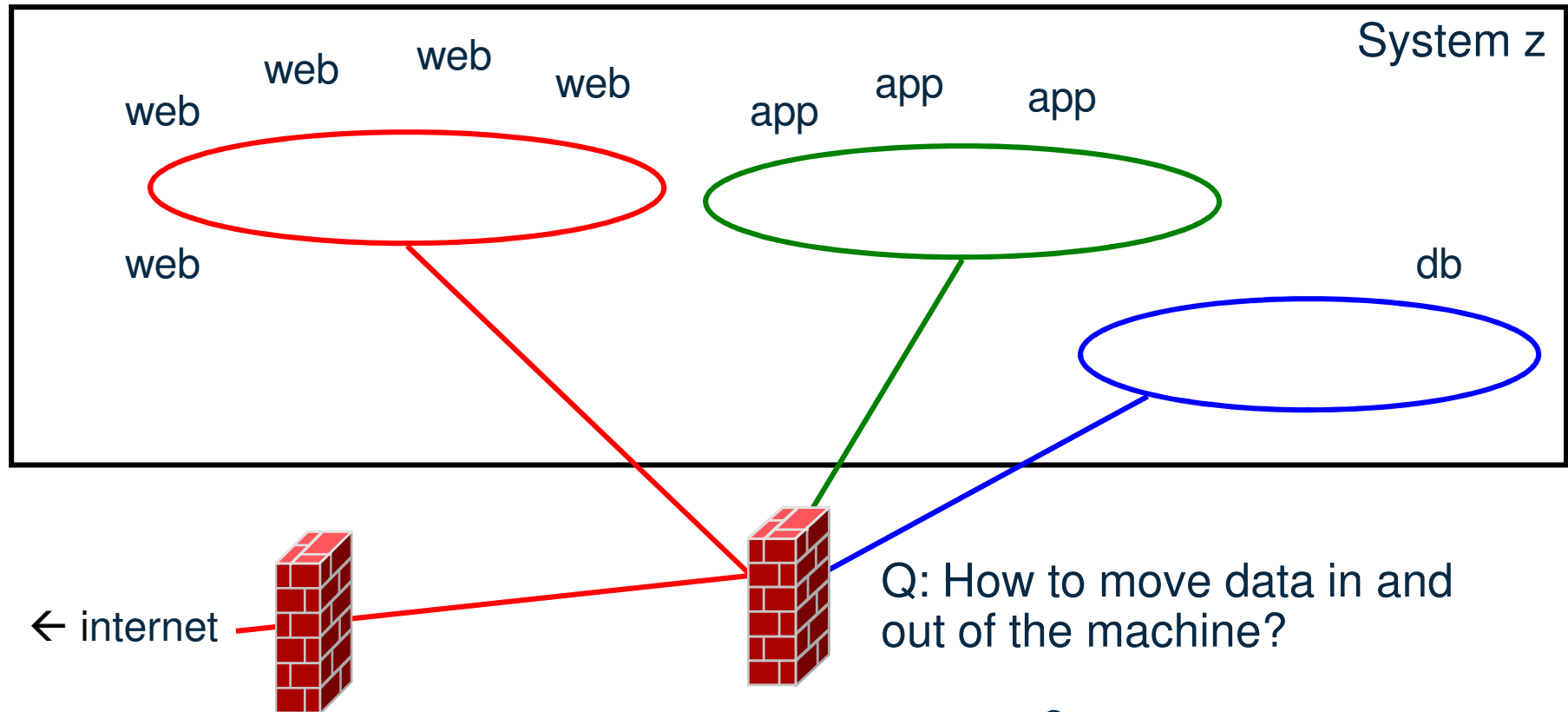

Q: How to move data in and out of the machine?

A: z/VM[®] Virtual Switch

What's a switch?

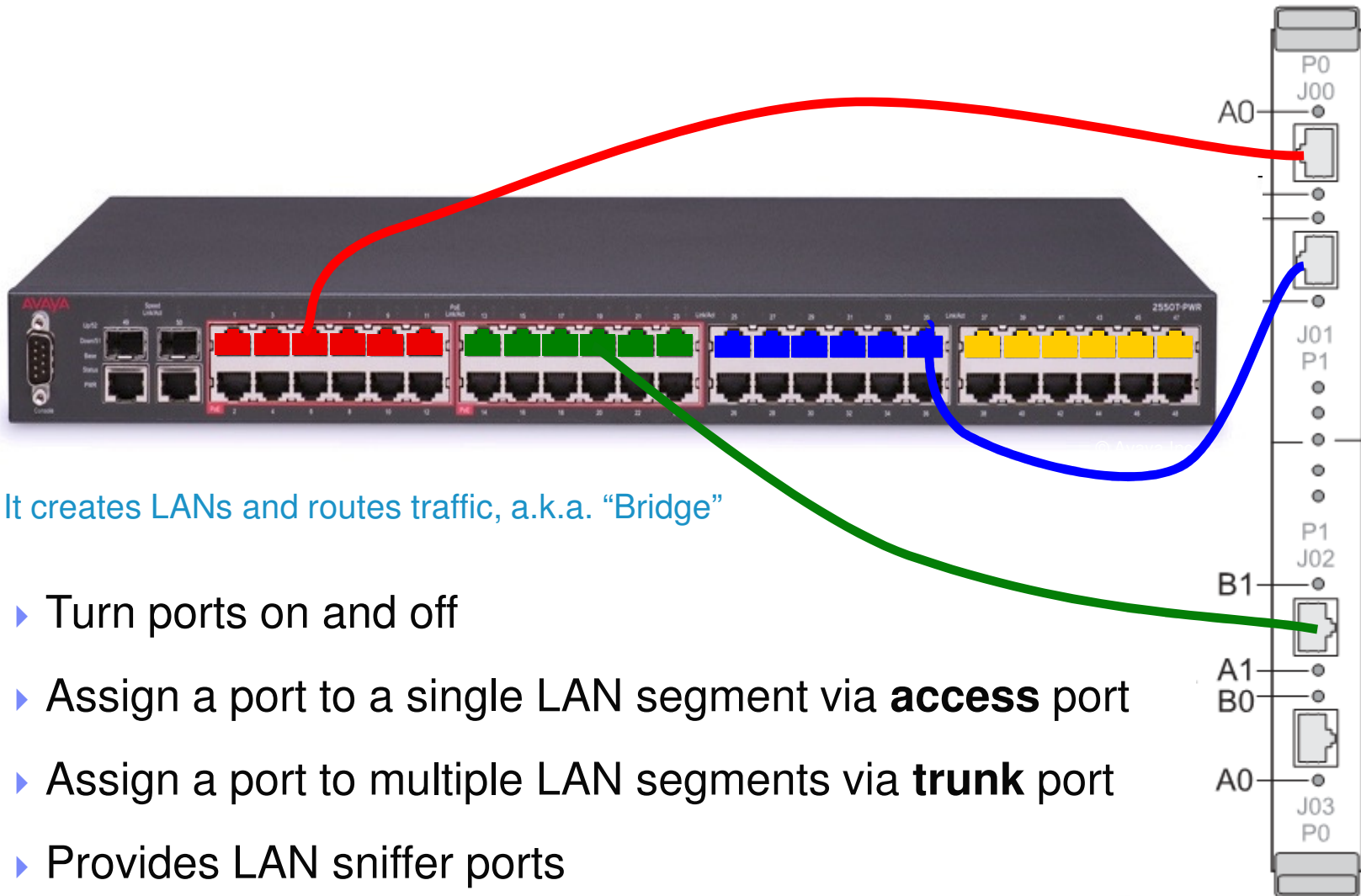

It creates LANs and routes traffic, a.k.a. “Bridge”

- ▶ Turn ports on and off
- ▶ Assign a port to a single LAN segment via **access** port
- ▶ Assign a port to multiple LAN segments via **trunk** port
- ▶ Provides LAN sniffer ports

Complete your session evaluations online at www.SHARE.org/Orlando-Eval

Copyright IBM Corporation, 2003-2015

Imbedded IP router (optional)

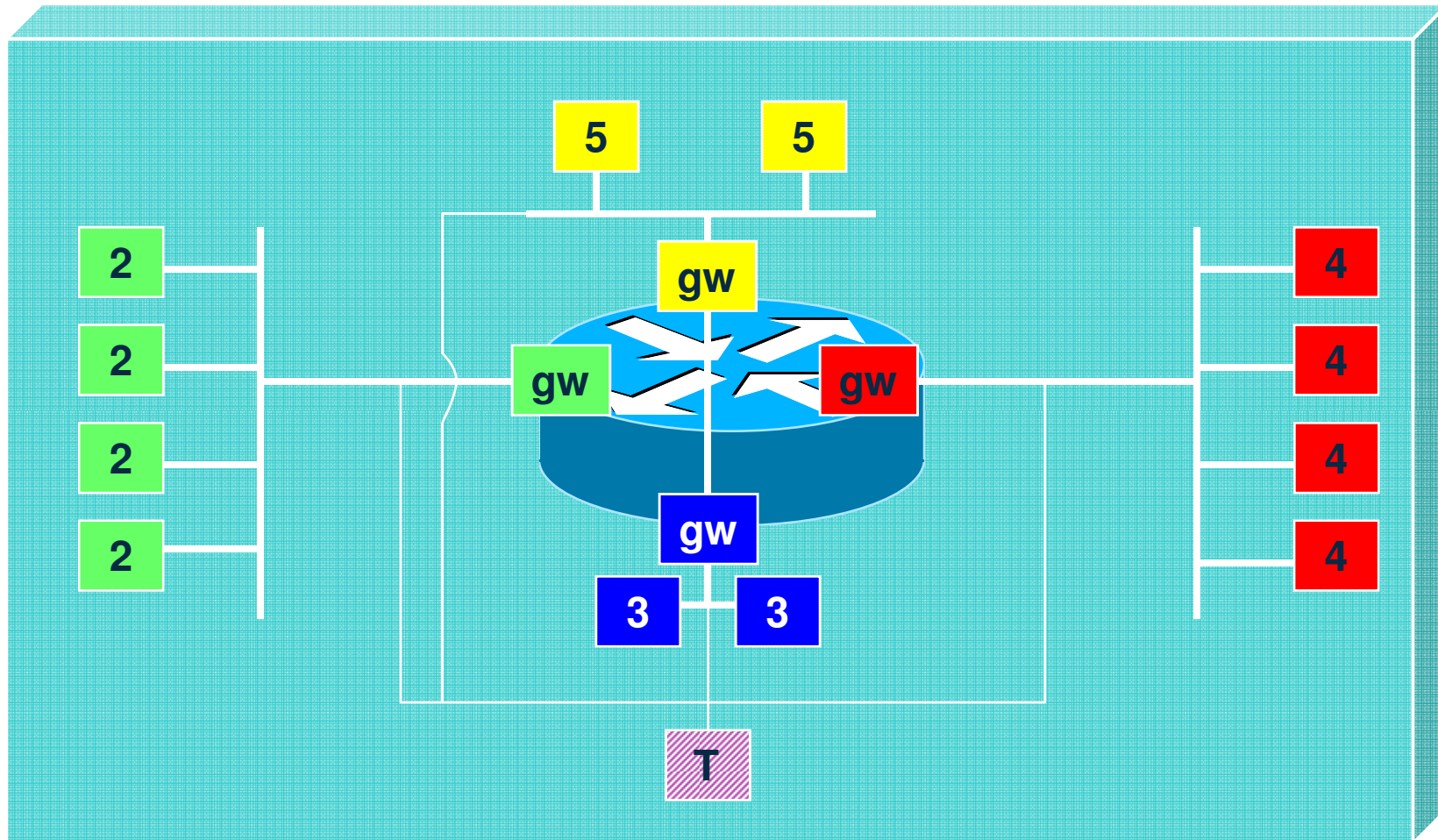

Complete your session evaluations online at www.SHARE.org/Orlando-Eval

Copyright IBM Corporation, 2003-2015

What's a "VLAN"?

- Defined by IEEE 802.1Q standard (not z/VM!)
 - “A subset of the active topology of a bridged LAN.”
- A bridged LAN is what you get when you use a switch instead of a hub
 - Enables the application of ingress and egress rules to the frames that enter and exit the switch ports
- IEEE 802.1Q establishes a new set of rules and frame formats
 - Associated with each VLAN is a VLAN Identifier (VID).
 - VLAN-tagged frames carry the VID within the frame. Allowed only on trunk ports.
 - Untagged frames do not carry the VID, but are instead associated with a VID by the switch and then managed as though they were tagged
- VLAN-aware bridges create logical groups of end stations that can communicate as if they were on the same LAN by associating the physical port used by each of those end stations with the same VID.
- Traffic between VLANs is restricted. Bridges forward unicast, multicast, and broadcast traffic to ports that serve the VLAN to which the traffic belongs.
 - Routers connect to multiple VLANs

VLAN tags

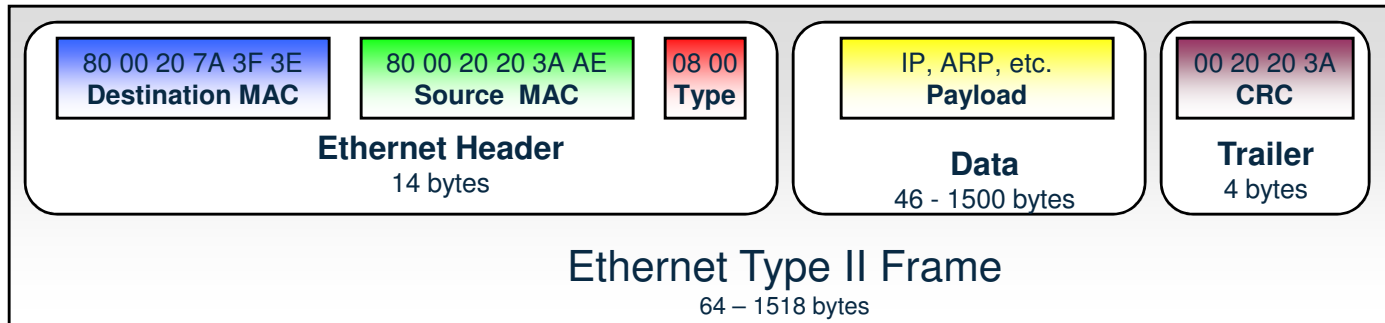

Access port and Trunk port

When used on a trunk port, the switch will associate (but not tag) it with the **native** VID.

Type/length 0800 means IPv4 (IETF RFC 894)

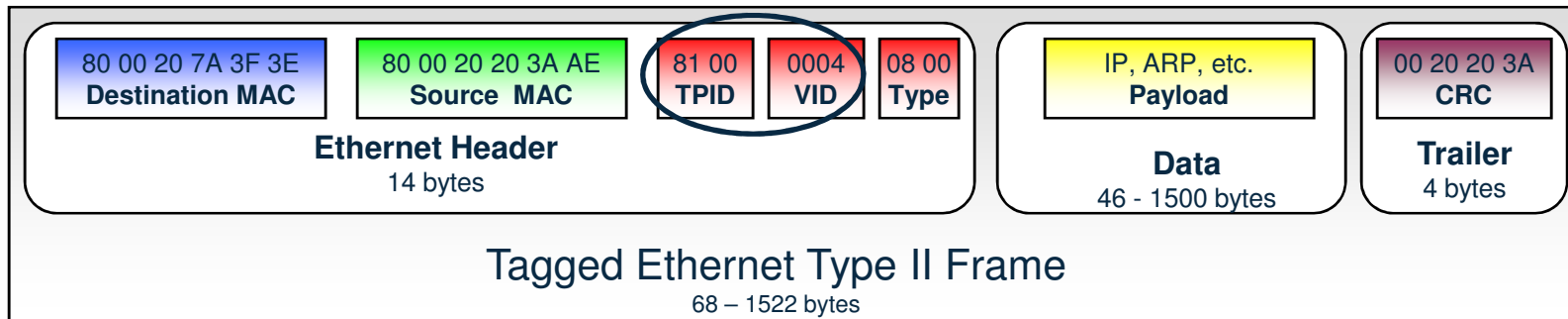

Trunk port only

Value 8100 in the Type field means a VLAN tag follows, followed by the actual type/length field

VLAN unaware sees only a single LAN segment

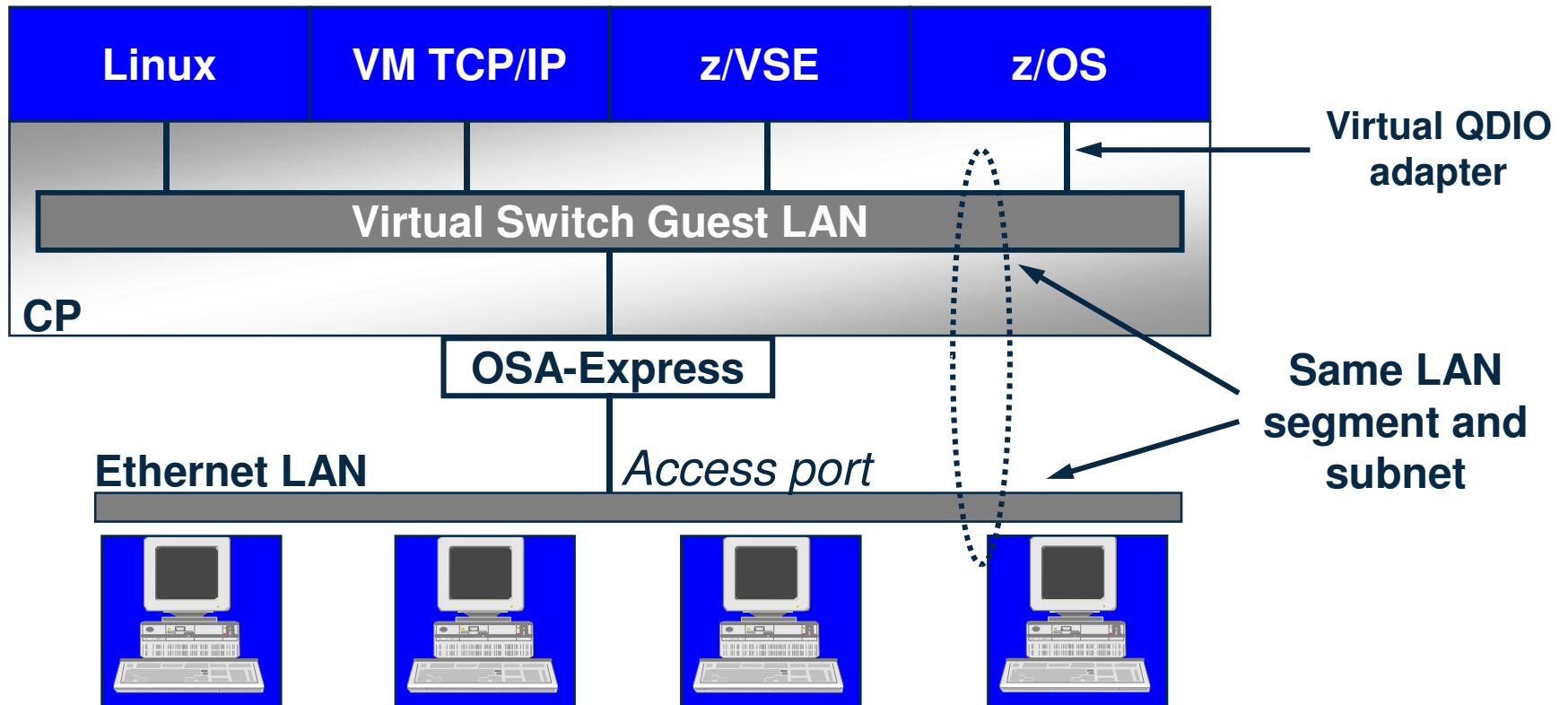

One VSWITCH per LAN segment

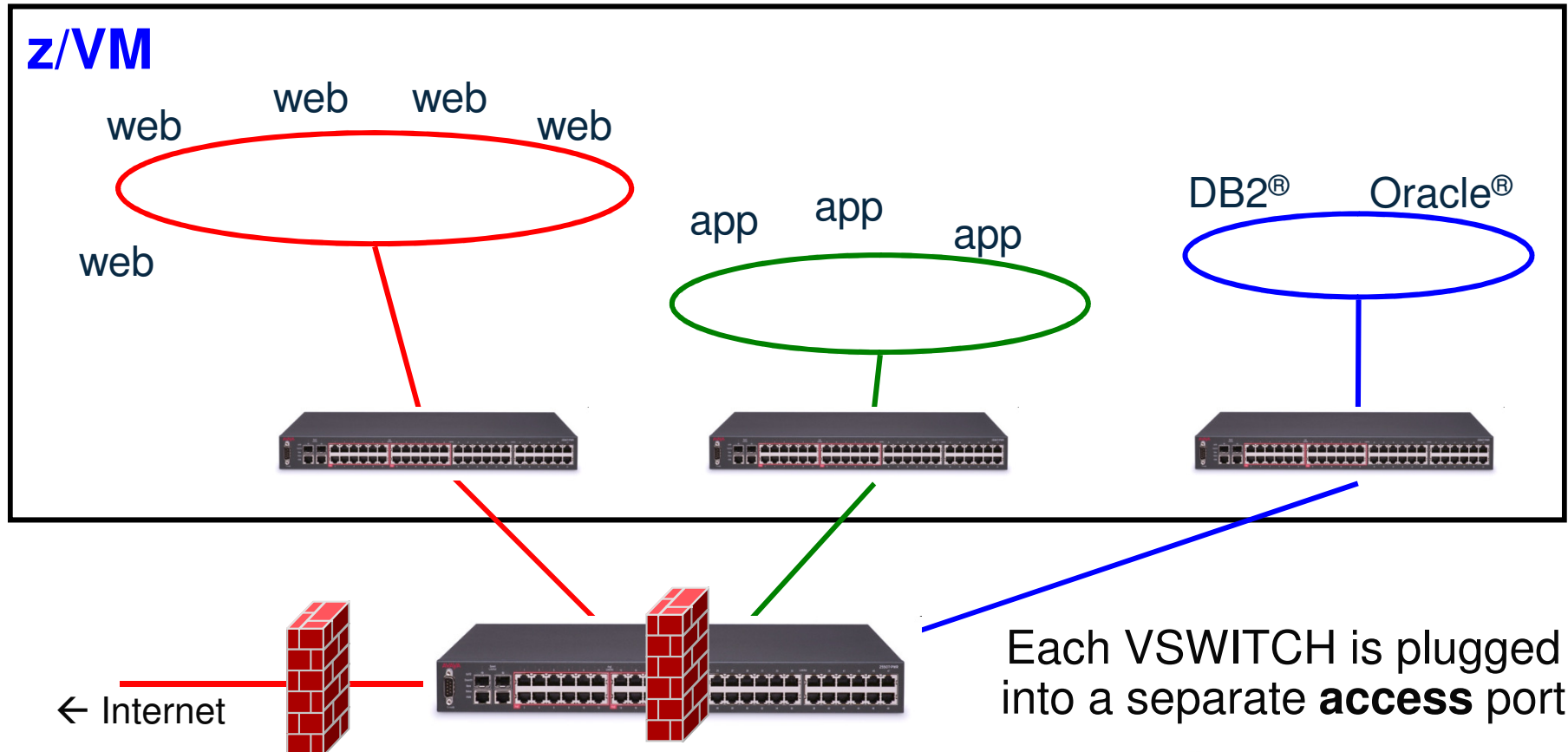

Complete your session evaluations online at www.SHARE.org/Orlando-Eval

Copyright IBM Corporation, 2003-2015

IEEE VLANs using a Trunk port

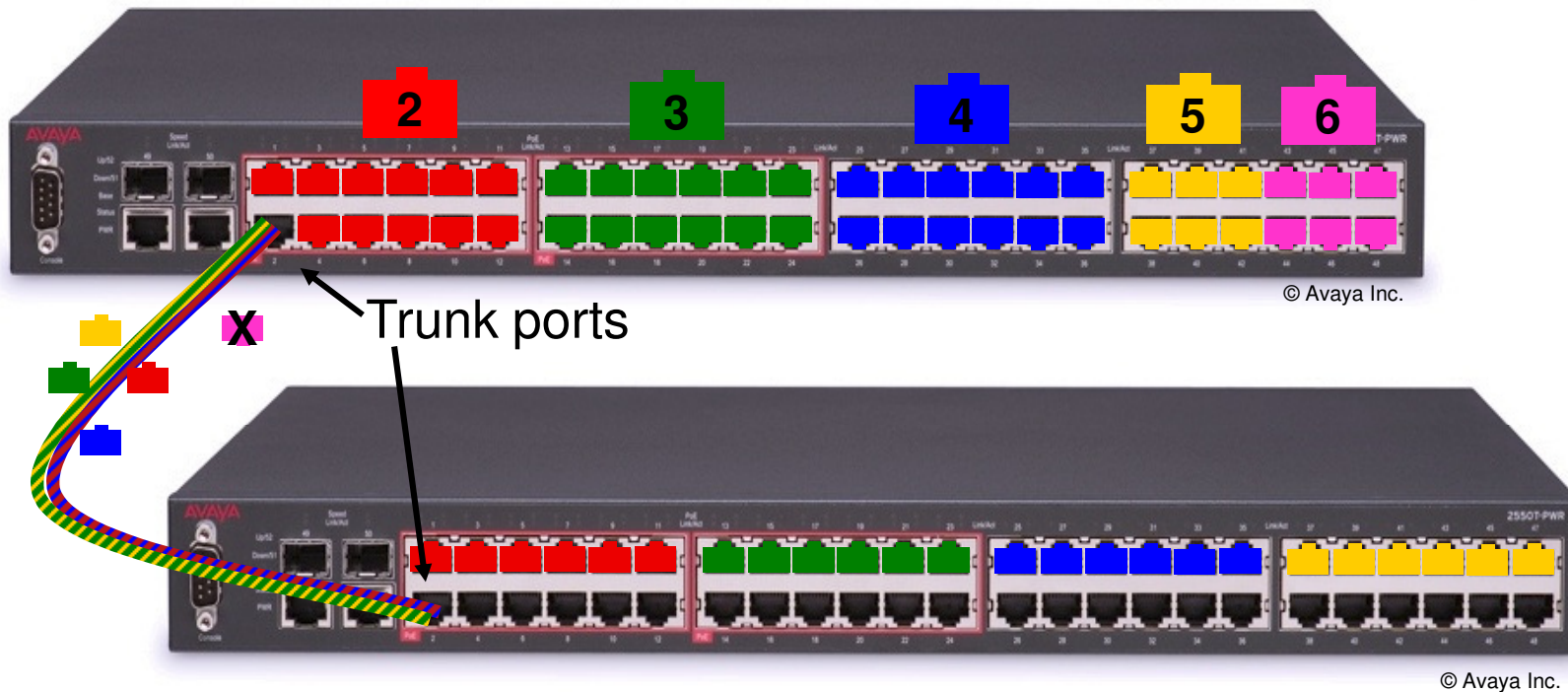

- ▶ If you run out of ports, you don't throw it away, you "trunk" it to another switch
- ▶ VLAN tags enable the trunk ports to identify the LAN segment to which a frame belongs.
- ▶ Single cable carries frames for multiple LAN segments

Complete your session evaluations online at www.SHARE.org/Orlando-Eval

Copyright IBM Corporation, 2003-2015

What is a native VLAN?

- When an untagged frame is received on a trunk port the switch will associate the frame with the local default or native VID (usually VLAN 1)
 - Identified by the NATIVE keyword on the DEFINE VSWITCH command
 - All inbound and outbound untagged frames are associated with this value for authorization purposes
 - Outbound frames tagged with the native VID will have the tag removed
- All switches should be configured with the same native VID
 - NATIVE NONE is preferred!

VLAN-aware Virtual Switch

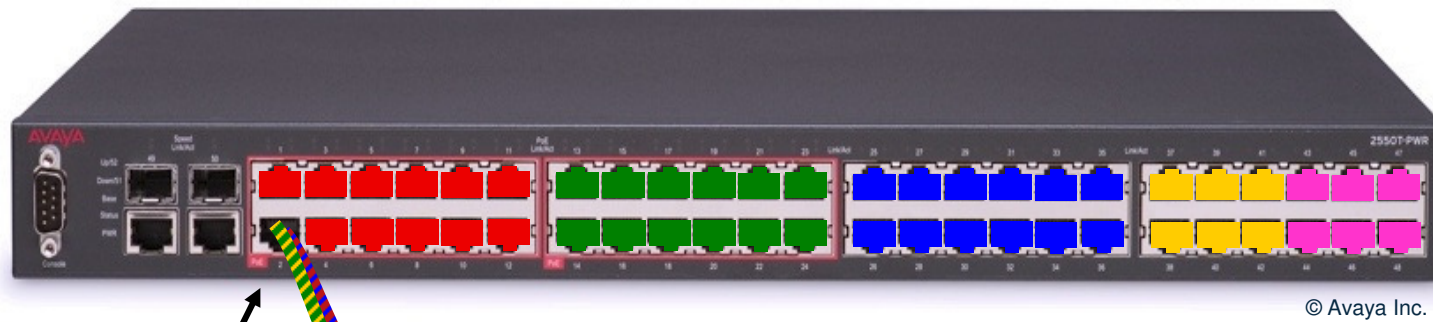

Trunk port

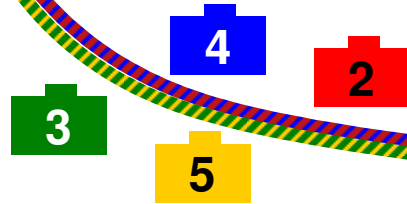

▶ Instead of a physical switch, plug in a virtual switch!

Multiple LAN segments per VSWITCH

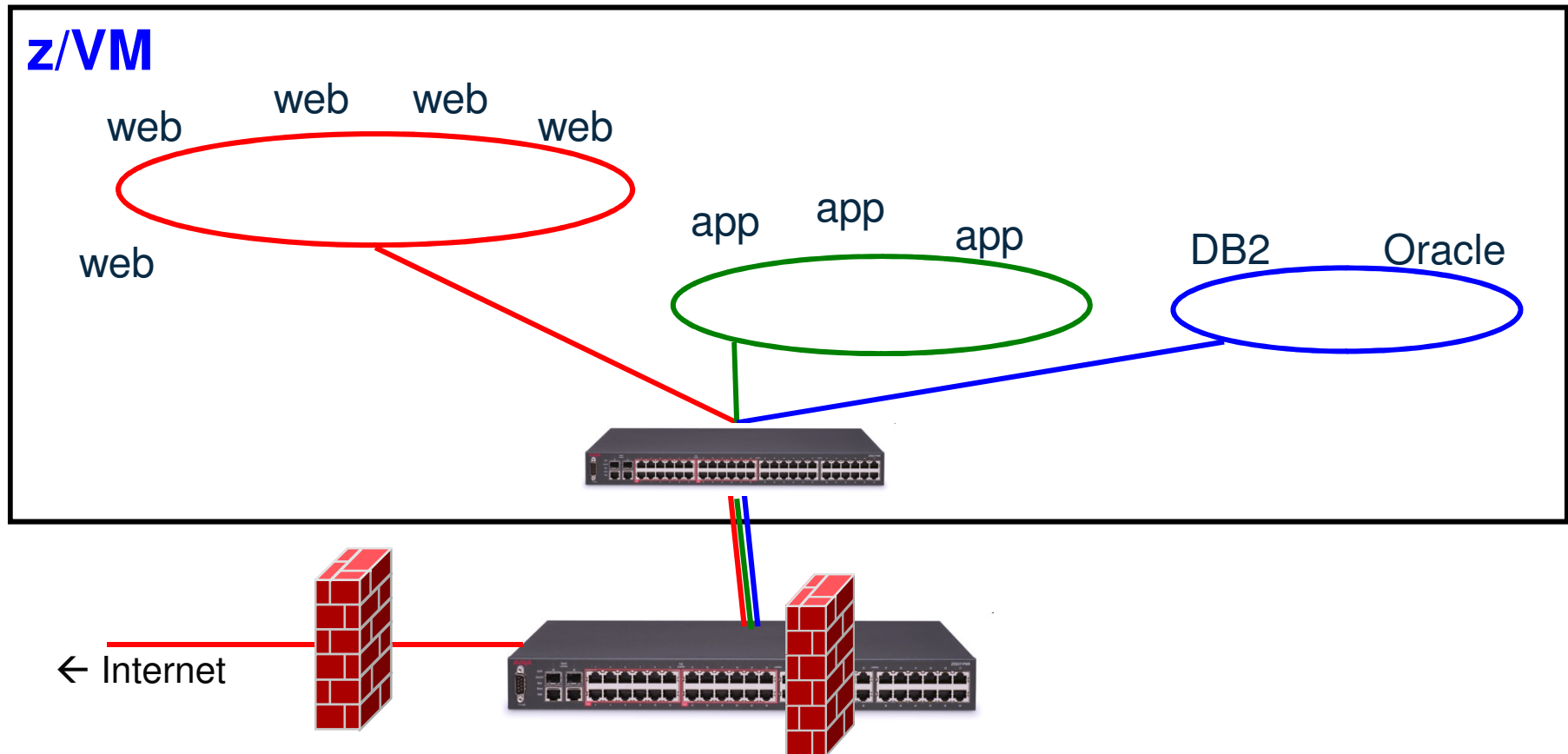

Single VSWITCH plugged into a trunk port

VLAN-aware Virtual Switch Sees all authorized LAN segments

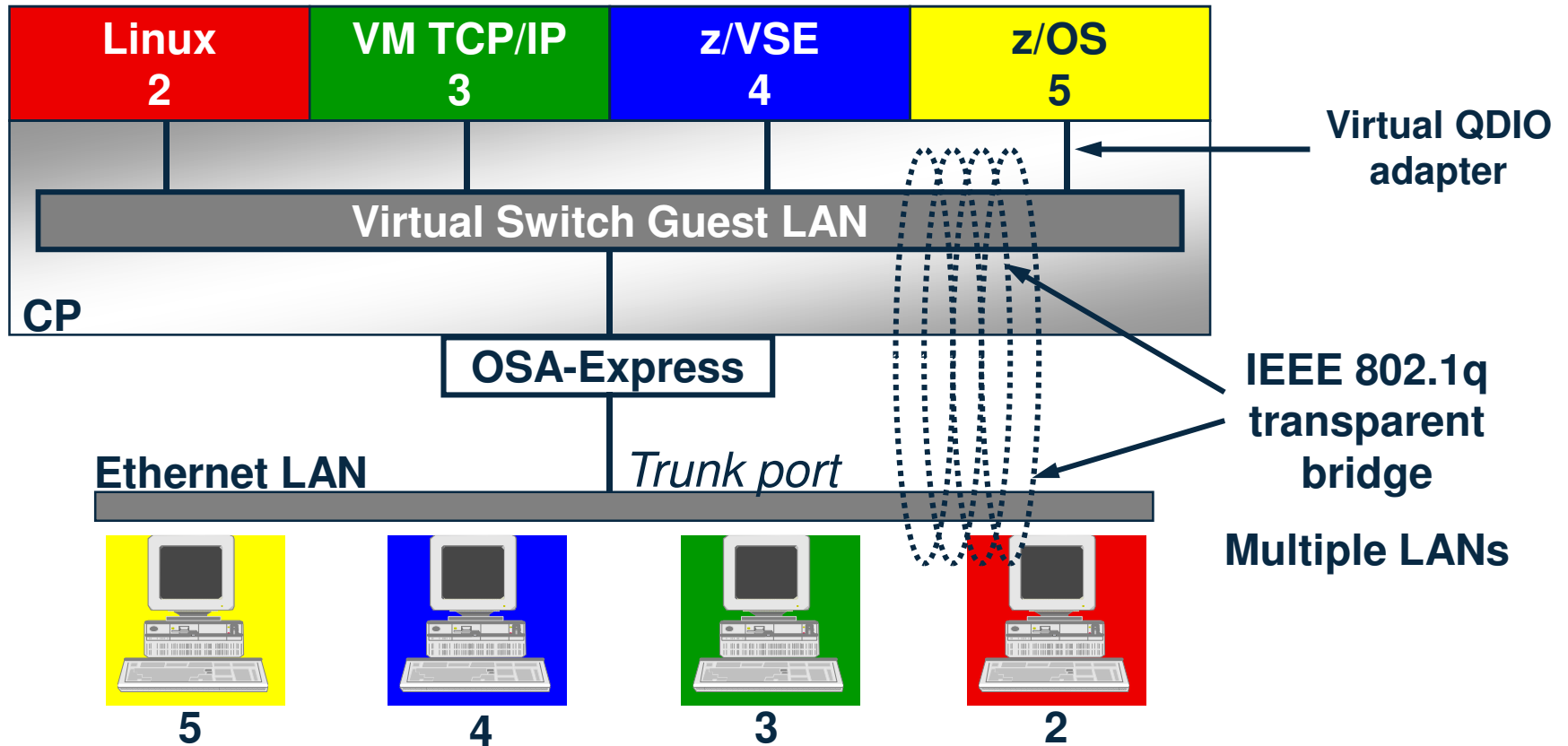

Complete your session evaluations online at www.SHARE.org/Orlando-Eval

Copyright IBM Corporation, 2003-2015

Primary Virtual Switch Attributes

- An associated controller virtual machine
- Mode of operation: Layer 2 or Layer 3
- Access list
 - Permitted user IDs
 - VLAN assignments
- Associated uplink: individual OSAs, link aggregation port group, virtual NIC, or none
- Unless otherwise configured, traffic remains as close to the virtual machines as possible
 - Within the VSWITCH
 - Within the OSA
 - Within the physical switch

VSWITCH Controller

- Virtual machine that handles OSA housekeeping duties
 - Specialized VM TCP/IP stack to start, stop, monitor, and query OSA
 - Not involved in data transfer
- IBM provides DTCVSW1 and DTCVSW2
 - No need to create more unless directed by Support Center
 - Leave them both logged on for redundancy
 - Monitor with system automation!
 - Automatic failover
- Do not ATTACH or DEDICATE devices
 - Handled by CP

Layer 2 and Layer 3

An OSA Point of View



- Layer 2 – Host sends/receives raw ethernet frames to OSA
 - Any protocol: IP, SNA, NETBIOS, AppleTalk, experimental, ...
 - CP registers virtual NIC MAC addresses with OSA so it can route inbound frames appropriately
 - Burned-in MAC address not used
 - Guest sends raw frame with its origin and target MAC address
 - Guest handles ARP
- Layer 3 – Host transfers only IP packets to OSA
 - CP registers guest IP addresses with OSA so it can route inbound packets properly
 - OSA places outbound packet in ethernet frame using burned-in MAC address
 - OSA handles ARP

Layer 2 and Layer 3 A Network Engineer's Point of View



- Layer 2 – Ethernet
 - Protocol agnostic
 - Knows which MACs are associated with which ports
 - Filters based on unicast v. multicast v. broadcast
- Layer 3 – Network Protocol
 - All the functions of a layer 2 switch
 - PLUS understands network (not just port-level) addressing
 - PLUS provides interconnect function among attached networks
 - “default gateway”
 - Which means it understands the protocol: IP, SNA, ...

Complete your session evaluations online at www.SHARE.org/Orlando-Eval

Copyright IBM Corporation, 2003-2015

Setting defaults and limits

- Global attributes in the VMLAN statement in SYSTEM CONFIG:

VMLAN

LIMIT TRANSIENT INFINITE | *maxcount* 

MACPREFIX *prefix1*

– For CP-assigned MACs

USERPREFIX *prefix2*

– For user-assigned MACs

MACIDRANGE SYSTEM *x-y* [USER *a-b*]

MACPROTECT OFF | ON 

- LIMIT TRANSIENT 0 prevents dynamic definition of Guest LANs by class G users – Don't use Guest LANs
- MACPROTECT ON prevents guests from changing their assigned MAC address

Virtual MAC Addresses

- MAC prefix = high-order 3 bytes of MAC address
 - 02:00:01
- MAC ID = low-order 3 bytes of MAC address
 - 00:01:23
- Concatenate to create virtual MAC address
 - 02:00:01:00:01:23

Virtual MAC Addresses

- VMLAN MACPREFIX in SYSTEM CONFIG
 - Set MAC prefix for CP-generated MAC addresses
 - Defaults to 02:00:00
 - Each instance of CP should have a different MACPREFIX
 - Must be different for Single System Image (enforced)
 - Avoids duplicate MAC addresses
- VMLAN USERPREFIX in SYSTEM CONFIG
 - Set MAC prefix for user-defined MAC addresses
 - Defaults to MACPREFIX value
 - Must be the same as MACPREFIX in a Single System Image cluster so that user-defined MAC addresses cannot overlap within the cluster

Virtual MAC Addresses

- VMLAN MACIDRANGE controls allocation of static (USER) and dynamic (SYSTEM) MAC addresses
 - Ensure no conflicts
 - USER range is a subset of SYSTEM range
 - Static MAC IDs must come from USER range
 - Not applicable to SSI
 - Default is entire range

- VMLAN MACIDRANGE SYSTEM 000001-002FFF
USER 002000-002FFF

Create a Layer 2 Virtual Switch

- SYSTEM CONFIG or CP command:

```
DEFINE VSWITCH name ETHERNET

    [RDEV NONE | cuu [cuu [cuu]] ]
    [GROUP group_name]
    [BRIDGEPORT cuu [PRIMARY] ]
    [USERBASED | PORTBASED]

    [MACPROTECT UNSPECIFIED | ON | OFF]

    [VLAN UNAWARE | VLAN AWARE | VLAN vid]
    [NATIVE 1 | NATIVE vid / NATIVE NONE]

    [CONNECT | DISCONNECT | NOUPLINK]
    [PORTTYPE ACCESS | PORTTYPE TRUNK]

MODIFY VSWITCH name ISOLATION OFF | ON
SET
```



Create a Layer 3 Virtual Switch

- SYSTEM CONFIG or CP command:

```
DEFINE VSWITCH name IP
MODIFY      [RDEV NONE | cuu [cuu [cuu]] ]
SET        [GROUP group_name

           [NONROUTER | PRIROUTER]

           [VLAN UNAWARE | VLAN AWARE | VLAN vid]
           [NATIVE 1 | NATIVE vid / NATIVE NONE]

           [ISOLATION OFF | ON]

           [CONNECT | DISCONNECT | NOUPLINK]
           [PORTTYPE ACCESS | PORTTYPE TRUNK]
           [CONTROLLER * | CONTROLLER userid]
```

User-based Virtual Switch access list

- Specify after DEFINE VSWITCH statement in SYSTEM CONFIG to add users to access list

```
MODIFY VSWITCH name GRANT userid VLAN vid ...  
SET [PORTTYPE ACCESS | TRUNK]  
[PRomiscuous | NOPROmiscuous]
```

```
SET VSWITCH name REVOKE userid
```

Examples:

```
MODIFY VSWITCH SWITCH12 GRANT LNX01 VLAN 3  
CP SET VSWITCH SWITCH12 GRANT LNX02 PORTTYPE TRUNK  
VLAN 4 20-22 29 302
```

```
CP SET VSWITCH SWITCH12 GRANT LNX02 PROMISCUOUS
```

User-based VSWITCH access list

- Implicit port definition
 - Ephemeral port number
 - Assigned in order defined
- VLAN assignment applies to all coupled NICs for the authorized user
- Port type applies to all coupled NICs for the authorized user
- SET VSWITCH GRANT
 - ESM controls override CP
 - If ESM defers, default VLAN ID will be used!

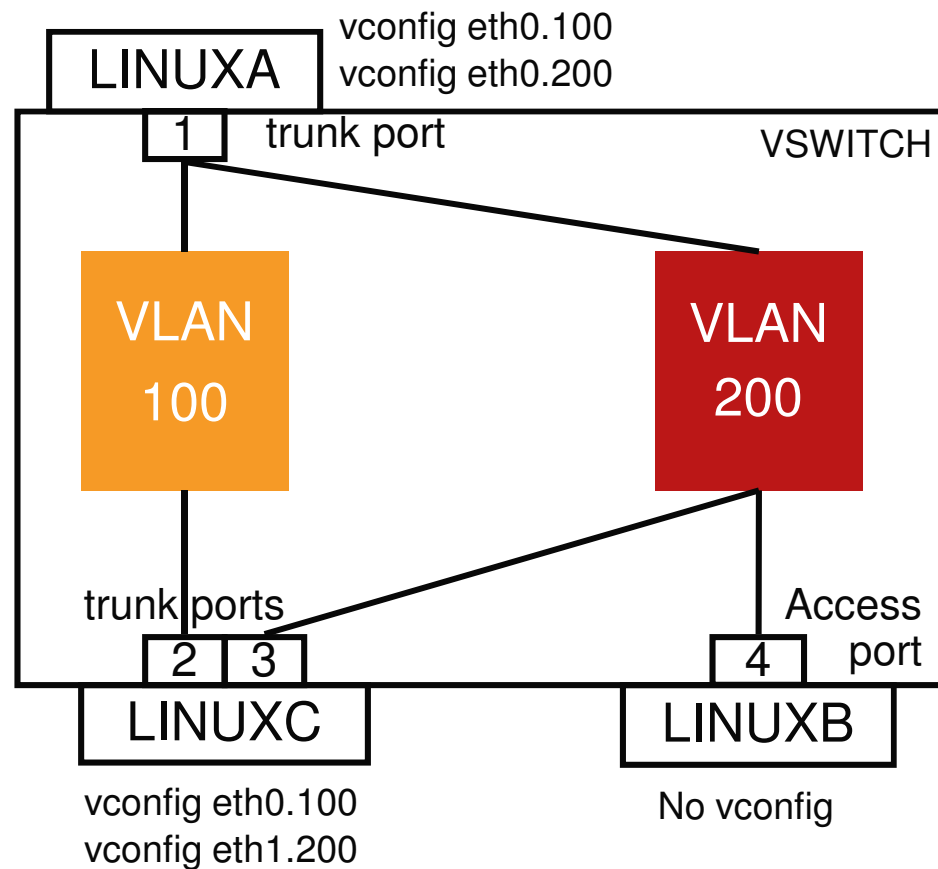

User-based VSWITCH access list

- define vswitch vsw1 vlan aware native none
- set vswitch vsw1 grant LINUXA porttype trunk VLAN 100 200
- set vswitch vsw1 grant FIREWALL porttype trunk VLAN 100 200
- set vswitch vsw1 grant LINUXB VLAN 200

- LINUXA: NICDEF 4E0 TYPE QDIO LAN SYSTEM VSW1
 - + vconfig eth0.100
 - + vconfig eth0.200

- LINUXB: NICDEF 4E0 TYPE QDIO LAN SYSTEM VSW1

- FIREWALL: NICDEF 4E0 TYPE QDIO LAN SYSTEM VSW1
 - NICDEF 5E0 TYPE QDIO LAN SYSTEM VSW1
 - + vconfig eth0.100
 - + vconfig eth1.200

Additional security controls

- Virtual Sniffers
 - Guest must be authorized via SET VSWITCH or security server
 - Guest enables promiscuous mode using CP SET NIC or via device driver controls
 - E.g. tcpdump -P
 - Guest receives copies of all frames sent or received for all authorized VLANs
 - Not needed when VEPA is used since frame goes to switch
- Port Isolation (aka “QDIO connection isolation”)
 - Stop guests from talking to each other, even when in same VLAN
 - Shut off OSA “short circuit” to other users (LPARs or guests) of the same OSA port or VSWITCH

Virtual Network Interface Card (NIC)

- A simulated network adapter
- 3 or more devices per NIC
 - More than 3 to simulate port sharing on 2nd-level system or for multiple data channels
- Provides access to Virtual Switch
- Created by NICDEF or CP DEFINE NIC command

Virtual NIC - User Directory

- One per interface in USER DIRECT file:

```
NICDEF vdev TYPE QDIO
      [LAN SYSTEM switch]
      [DEVICES nn]           Combined with VMLAN
      [MACID xyyyzz]       USERPREFIX to create
                           virtual MAC
```

Example:

```
NICDEF 1100 TYPE QDIO LAN SYSTEM SWITCH1 MACID B10006
```

Virtual NIC - CP Command

- May be interactive with CP DEFINE NIC and COUPLE commands:

```
CP DEFINE NIC vdev TYPE QDIO
```

```
CP COUPLE vdev [TO] owner name
```

Example:

```
CP DEFINE NIC 1200 TYPE QDIO
```

```
CP COUPLE 1200 TO SYSTEM SWITCH12
```

SET NIC

- SET NIC [USER userid] vdev ...
 - PROMISCUOUS | NOPROMISCUOUS (class G)
 - MACID SYSTEM (class B)
 - MACID USER hhhhhh (class B)
 - MACPROTECT UNSPECIFIED | OFF | ON (class B)

Best Practices

- Use ETHERNET (layer 2) VSWITCH
- Do not specify CONTROLLER
- Do not specify PORTTYPE TRUNK on DEFINE VSWITCH
 - This controls the default guest port type, not the OSA!
- Do not put CONTROLLER ON in your own TCP/IP stacks
- Specify MACPROTECT ON and LIMIT TRANSIENT 0 on VMLAN statement in SYSTEM CONFIG

Best Practice for VLAN-aware VSWITCH

- DEFINE VSWITCH
VLAN AWARE
NATIVE NONE
PORTTYPE ACCESS (or do not specify)
- Explicitly GRANT guest to a particular VLAN ID
- Guest that has not been given access will get errors
- Use ESM and groups to manage VLAN assignments
 - Simplifies VLAN changes

Additional Virtual Switch Technologies

- Link aggregation (channel bonding)
- Shared Link Aggregation port groups
- HiperSocket Bridge
- Virtual Ethernet Port Aggregator (VEPA)
- Port-based authorization
- SNMP MIB

Stay tuned!

Complete your session evaluations online at www.SHARE.org/Orlando-Eval

Copyright IBM Corporation, 2003-2015

Diagnostics

- CP QUERY VMLAN
 - to get global VM LAN information (e.g. limits)
 - to find out what service has been applied
- CP QUERY VSWITCH ACTIVE
 - to find out which users are coupled
 - to find out which IP addresses are active
- CP QUERY NIC DETAILS
 - to find out if your adapter is coupled
 - to find out if your adapter is initialized
 - to find out if your IP addresses have been registered
 - to find out how many bytes/packets sent/received

Summary

- VSWITCHes make it easy to control access to the network and simplify server cloning
- Use IEEE VLANs to simplify configuration
- Use Link Aggregation for best availability
- Integrate into SNMP-based monitoring solutions

Support Timeline

z/VM 6.3	<ul style="list-style-type: none"> ▪ Shared link aggregation port groups ▪ VEPA ▪ SET VSWITCH SWITCHOVER
z/VM 6.2	<ul style="list-style-type: none"> ▪ Port-based configuration provides separate VLAN per virtual access port ▪ HiperSocket bridge
z/VM 6.1	<ul style="list-style-type: none"> ▪ Uplink port can be OSA or guest ▪ zEnterprise ensembles (IEDN and INMN) [deprecated] ▪ VLAN UNAWARE, NATIVE NONE
z/VM V5	<ul style="list-style-type: none"> ▪ Virtual and physical port isolation ▪ z/VM TCP/IP support for Layer 2 ▪ Link aggregation ▪ SNMP monitor ▪ Virtual SPAN ports for sniffers ▪ Virtual trunk and access port controls ▪ Layer 2 (MAC) frame transport ▪ External security manager access control
z/VM V4	<ul style="list-style-type: none"> ▪ Layer 3 (IPv4 only) Virtual Switch with IEEE VLANs ▪ Guest LAN with OSA and HiperSocket simulation

Complete your session evaluations online at www.SHARE.org/Orlando-Eval

Copyright IBM Corporation, 2003-2015

References

- Publications:
 - z/VM CP Planning and Administration
 - z/VM CP Command and Utility Reference
 - z/VM Connectivity

Contact Information



Alan C. Altmark

Senior Managing z/VM Consultant

z Systems Delivery Practice
IBM Systems Lab Services

IBM

*1701 North Street
Endicott, NY 13760*

Mobile 607 321 7556

Fax 607 429 3323

Email: alan_altmark@us.ibm.com



Mailing lists: IBMTCP-L@vm.marist.edu
IBMVM@listserv.uark.edu
LINUX-390@vm.marist.edu

See <http://ibm.com/vm/techinfo/listserv.html> for details.

Complete your session evaluations online at www.SHARE.org/Orlando-Eval

Copyright IBM Corporation, 2003-2015

