



| z Systems

Introduction to Virtualization

SHARE Orlando
Linux and VM Program

Romney White, IBM

romneyw@us.ibm.com
z Systems Architecture and Technology



- **Introduction to Virtualization**
 - Concept
 - Server Virtualization Approaches
 - Hypervisor Implementation Methods
 - Why Virtualization Matters
- **Virtualization on z Systems**
 - Logical Partitions
 - Virtual Machines

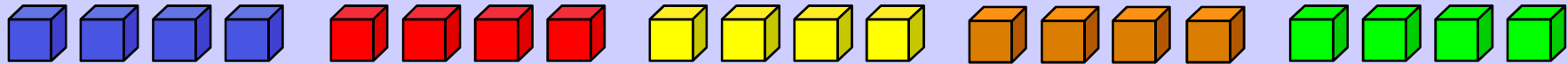

Virtual Resources

- Proxies for real resources: **same interfaces/functions, different attributes**
- May be part of a physical resource or multiple physical resources

Virtualization

- Creates virtual resources and "maps" them to real resources
- Primarily accomplished with software or firmware

Resources

- Components with **architecturally-defined interfaces/functions**
- May be centralized or distributed - usually physical
- Examples: memory, disk drives, networks, servers

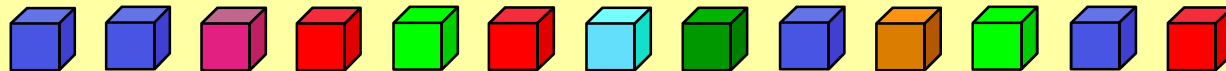

- **Separates presentation of resources to users from actual resources**
- **Aggregates pools of resources for allocation to users as virtual resources**

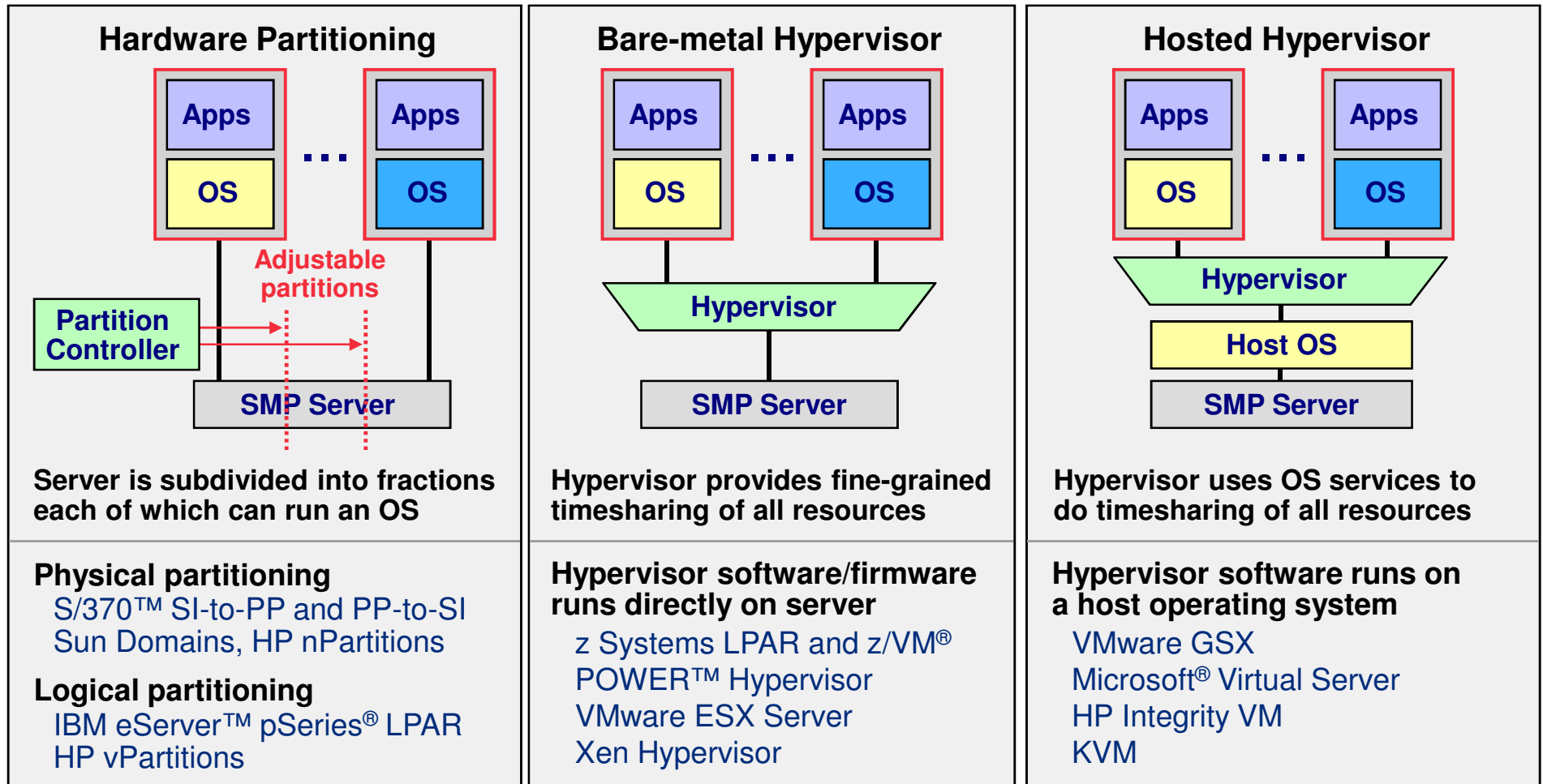

Characteristics:

- Bare-metal hypervisors offer high efficiency and availability
- Hosted hypervisors are useful for clients where host OS integration is important
- Hardware partitioning is less flexible than hypervisor-based solutions

Trap and Emulate

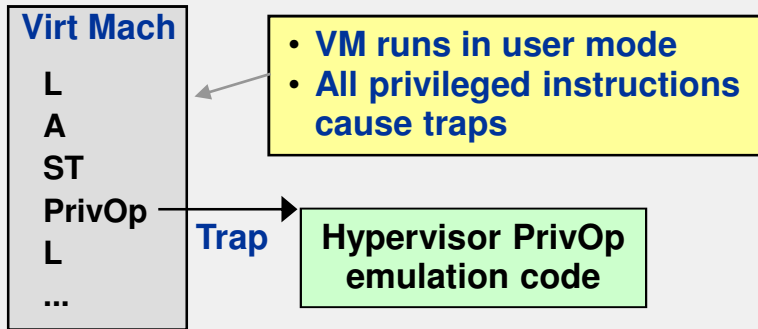

Examples CP-67, VM/370
 Benefits Runs unmodified OS
 Issues Substantial overhead

Translate, Trap, and Emulate

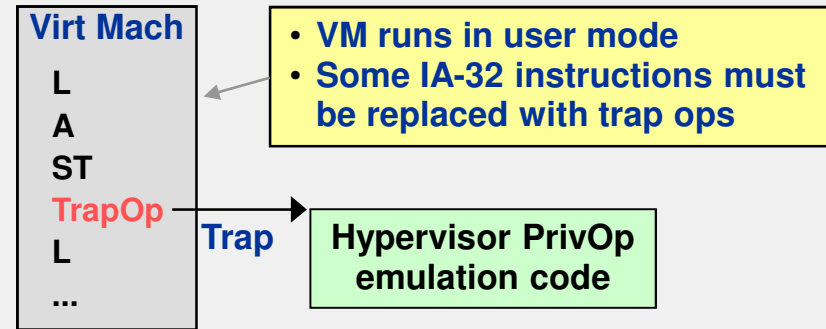

Examples VMware, Microsoft VS
 Benefits Runs unmodified, translated OS
 Issues Substantial overhead

Hypervisor Calls (“Paravirtualization”)

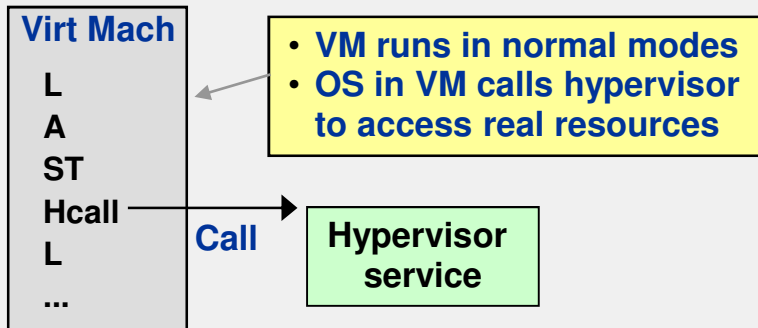

Examples POWER Hypervisor, Xen
 Benefits High efficiency
 Issues OS must be modified to issue Hcalls

Direct Hardware Virtualization

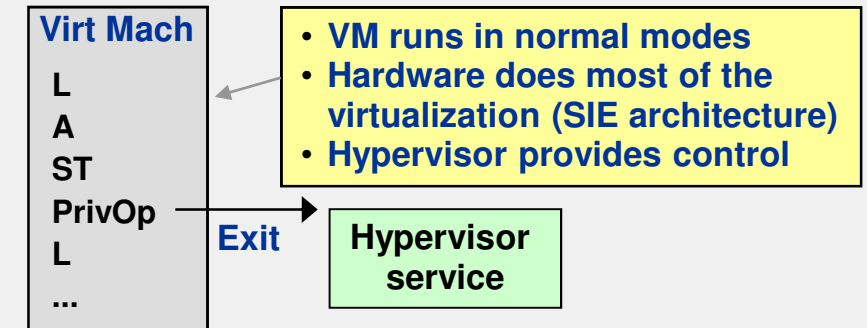

Examples z Systems LPAR, z/VM, Xen
 Benefits High efficiency, runs unmodified OS
 Issues Requires underlying hardware support

Roles:

- Consolidations
- Dynamic provisioning / hosting
- Workload management
- Workload isolation
- Software release migration
- Mixed production and test
- Mixed OS types/releases
- Reconfigurable clusters
- Low-cost backup servers

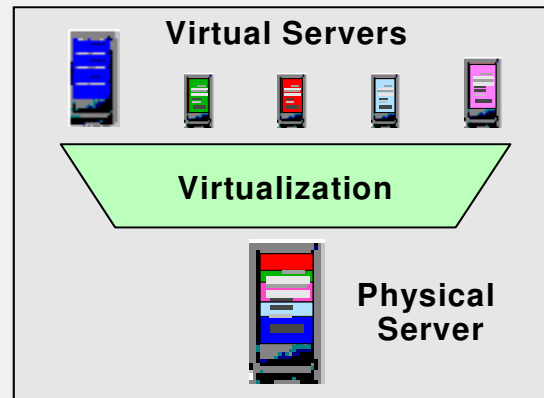

Possible Benefits:

- High resource utilization
- Great usage flexibility
- Enhanced workload QoS
- High availability / security
- Low cost of availability
- Low management costs
- Enhanced interoperability
- Legacy compatibility
- Investment protection

Virtualization can fill many roles and provide many benefits
In the final analysis, its potential benefits take three forms:

- **Help reduce hardware costs**
 - Help increase physical resource utilization
 - Small footprints
- **Can improve flexibility and responsiveness**
 - Virtual resources can be adjusted dynamically to meet new or changing needs and to optimize service level achievement
 - Virtualization is a key enabler of on demand operating environments such as cloud
- **Can reduce management costs**
 - Fewer physical servers to manage
 - Many common management tasks become much easier

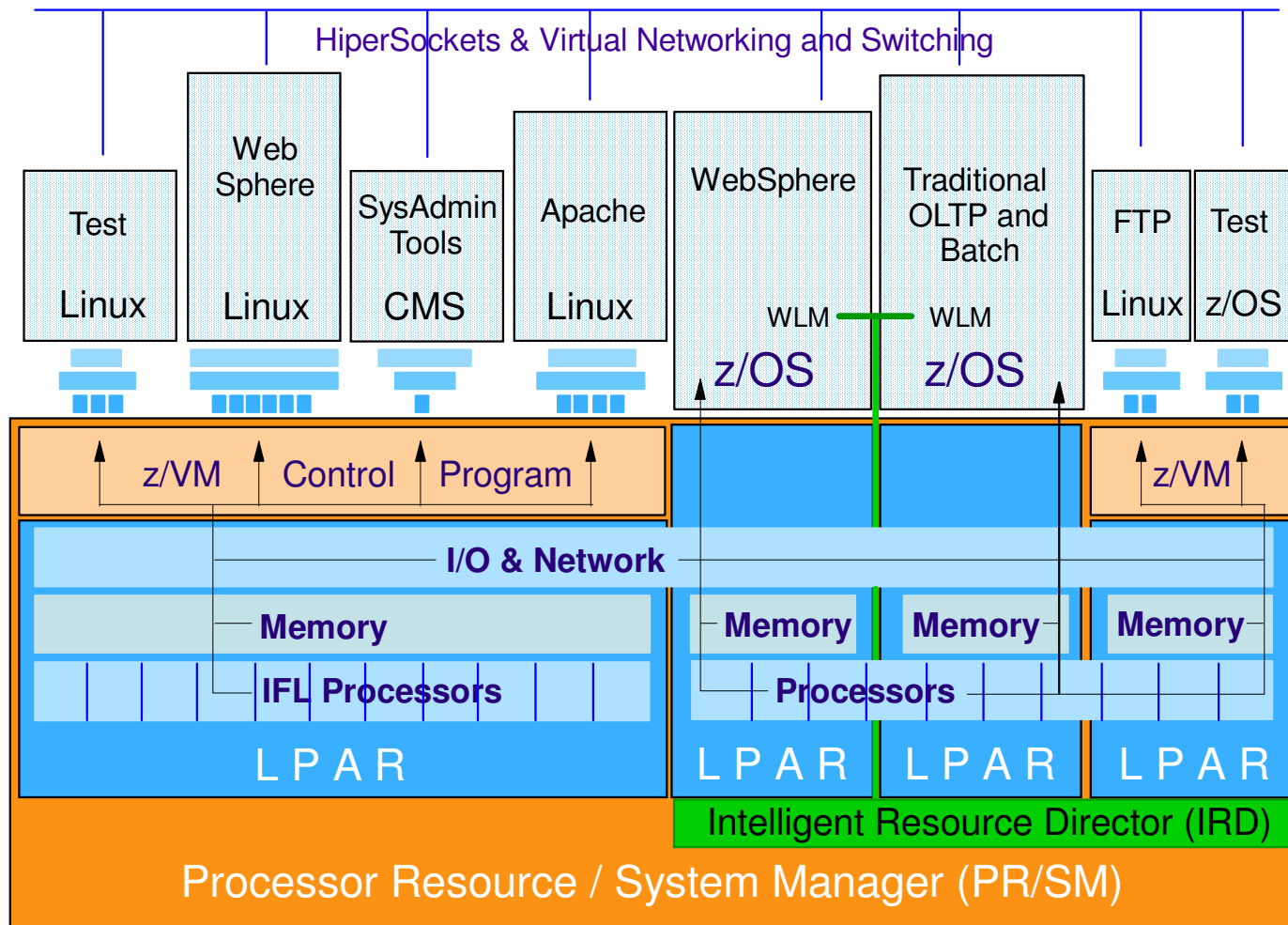

Multi-dimensional virtualization technology

- z Systems provides logical (LPAR) and software (z/VM) partitioning
- PR/SM enables highly scalable virtual server hosting for LPAR *and* z/VM virtual machine environments
- IRD coordinates allocation of CPU and I/O resources among z/OS and non-z/OS® LPARs*

* Excluding non-shared resources like Integrated Facility for Linux processors

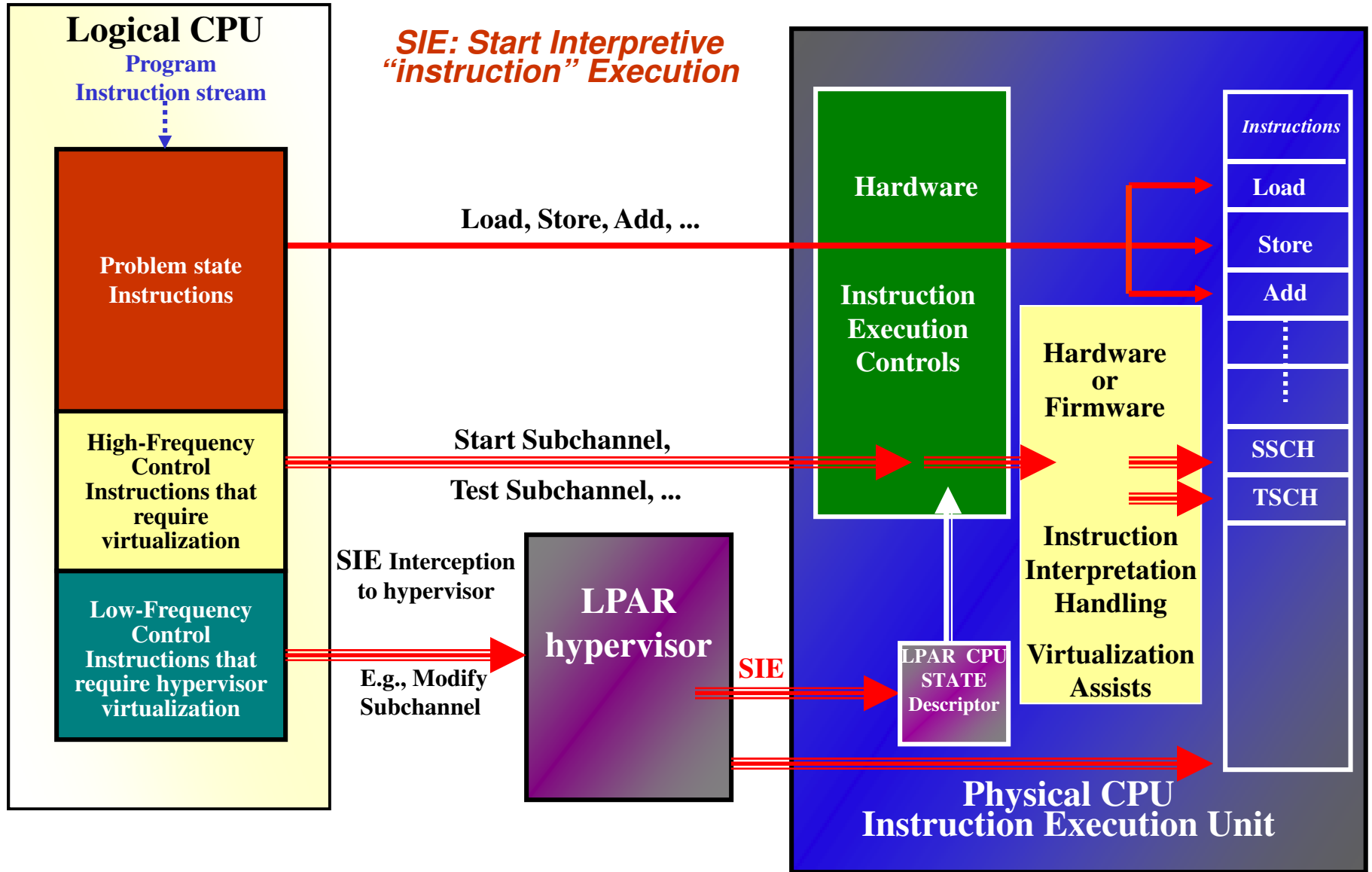

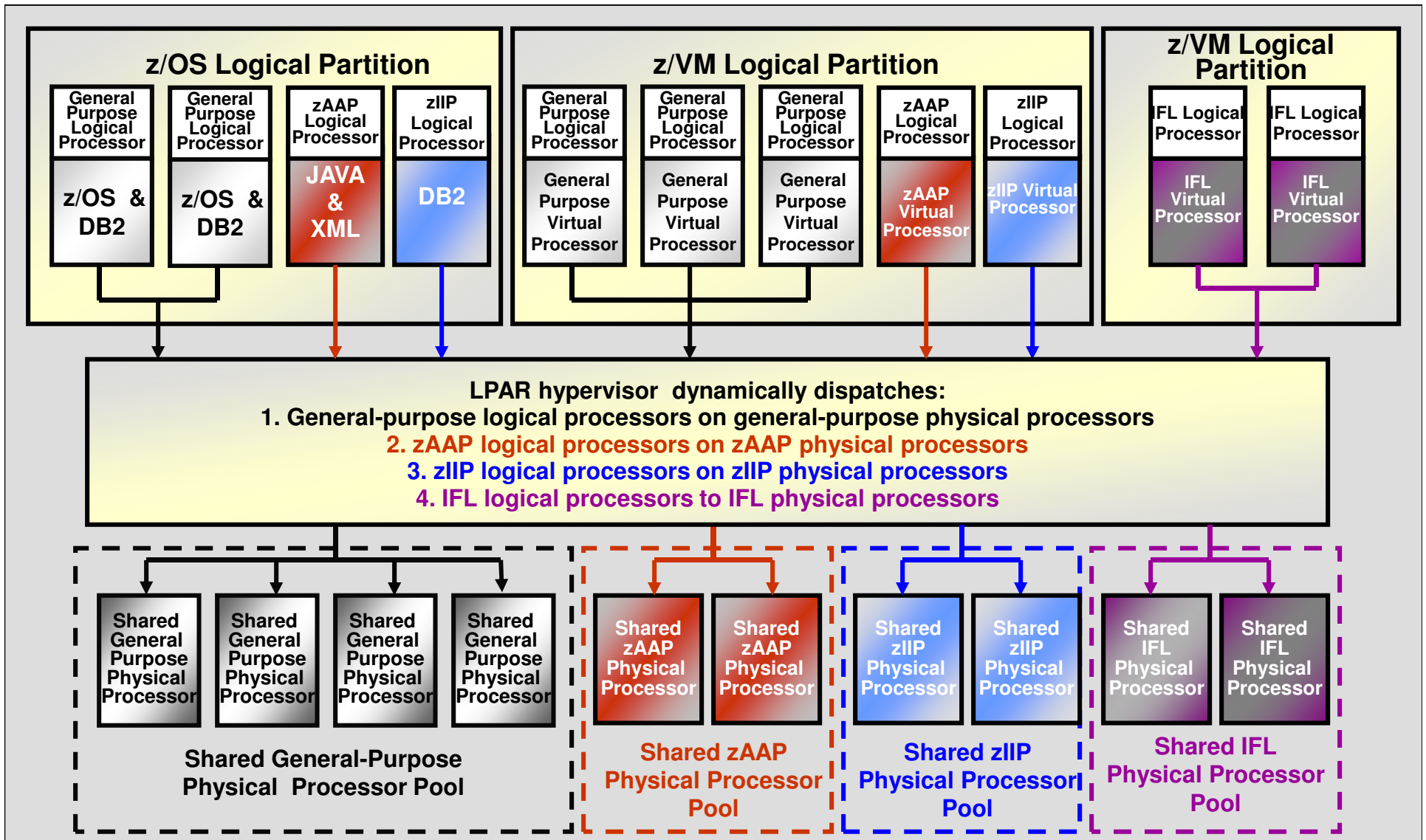

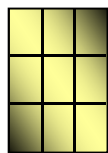
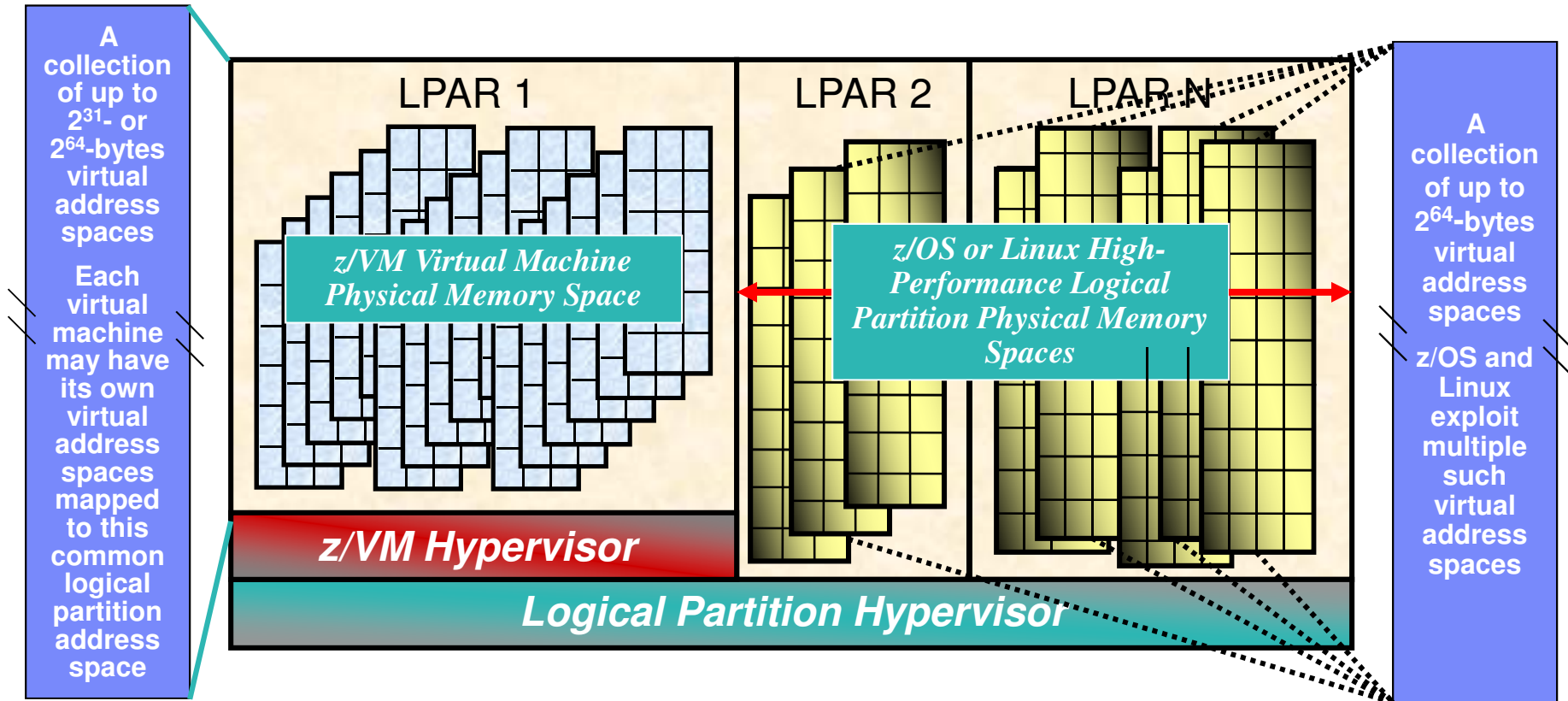

= the real partition memory pages associated with a virtual address space; that is, the sets of dynamically-allocated physical memory pages necessary to run a z/OS task or a Linux process



= the real partition memory pages associated with a virtual machine; that is, the sets of dynamically-allocated physical memory pages necessary to run a guest operating system in a virtual machine

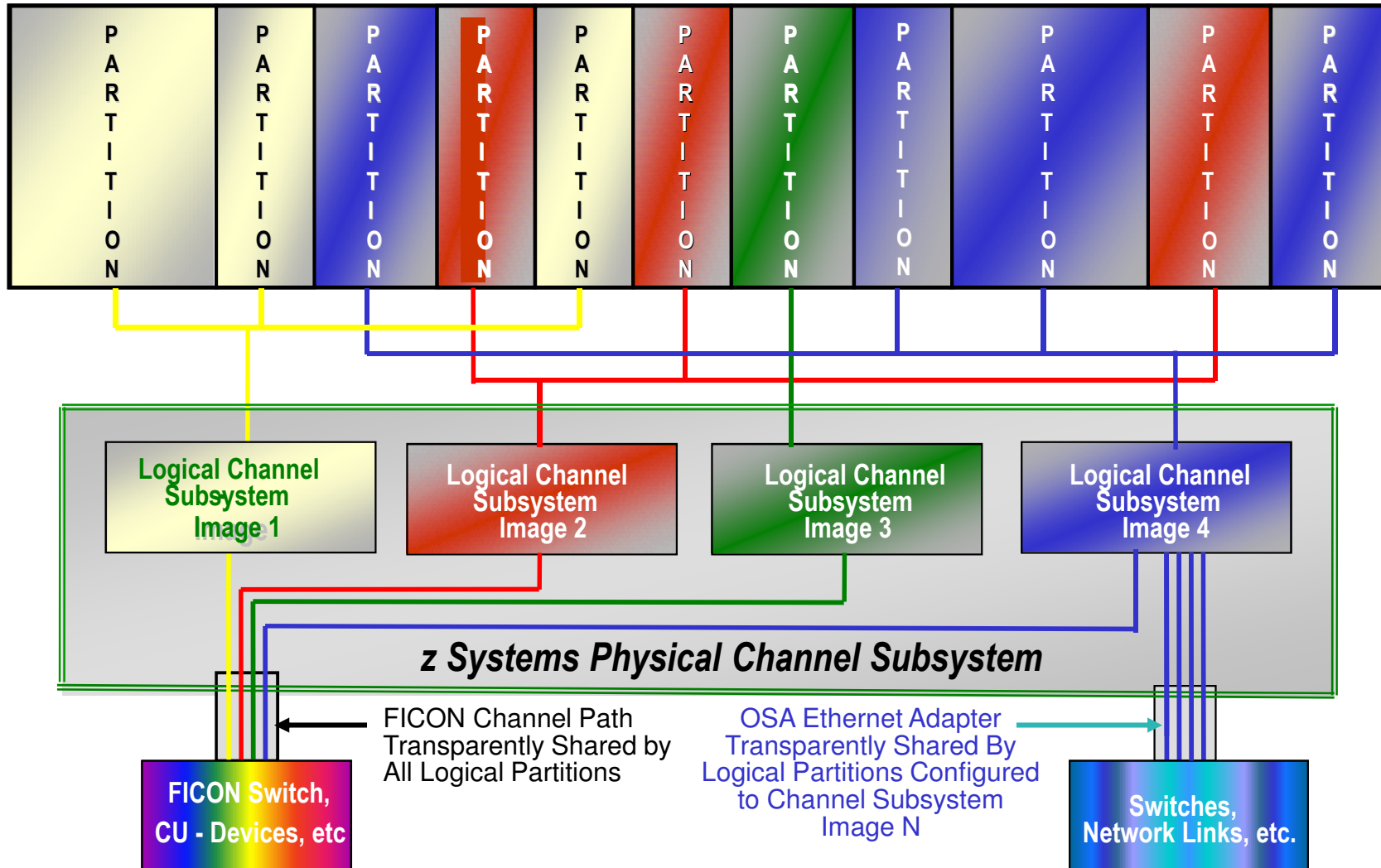

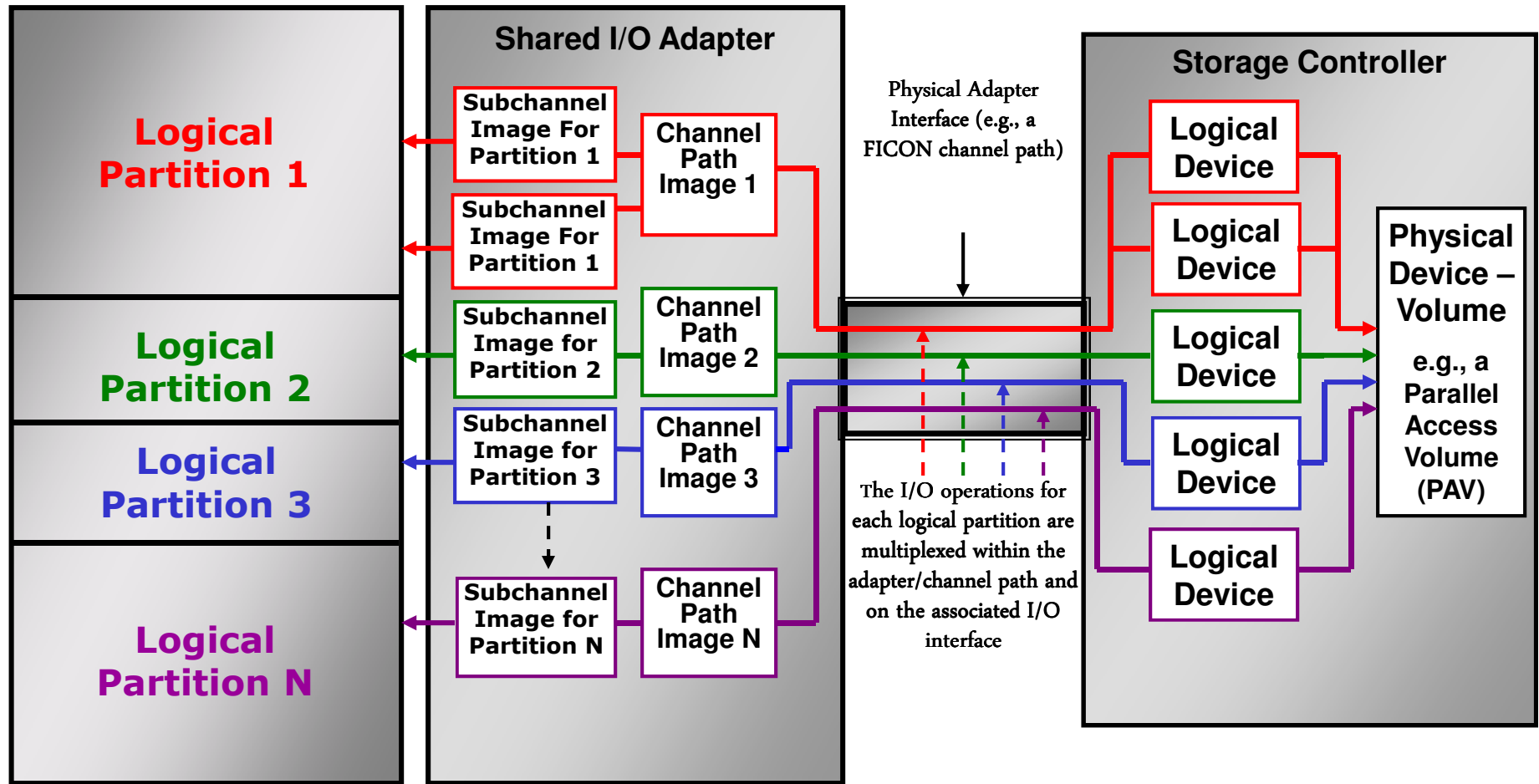

- The I/O infrastructure (adapters/channels, their transmission links, and attached I/O resources) are shared by LPARs at native speeds (without hypervisor involvement)
 - I/O requests, their associated data transfers, and I/O interruptions flow between each OS instance and the shared I/O components, just as if the I/O components were physically dedicated to a single OS instance

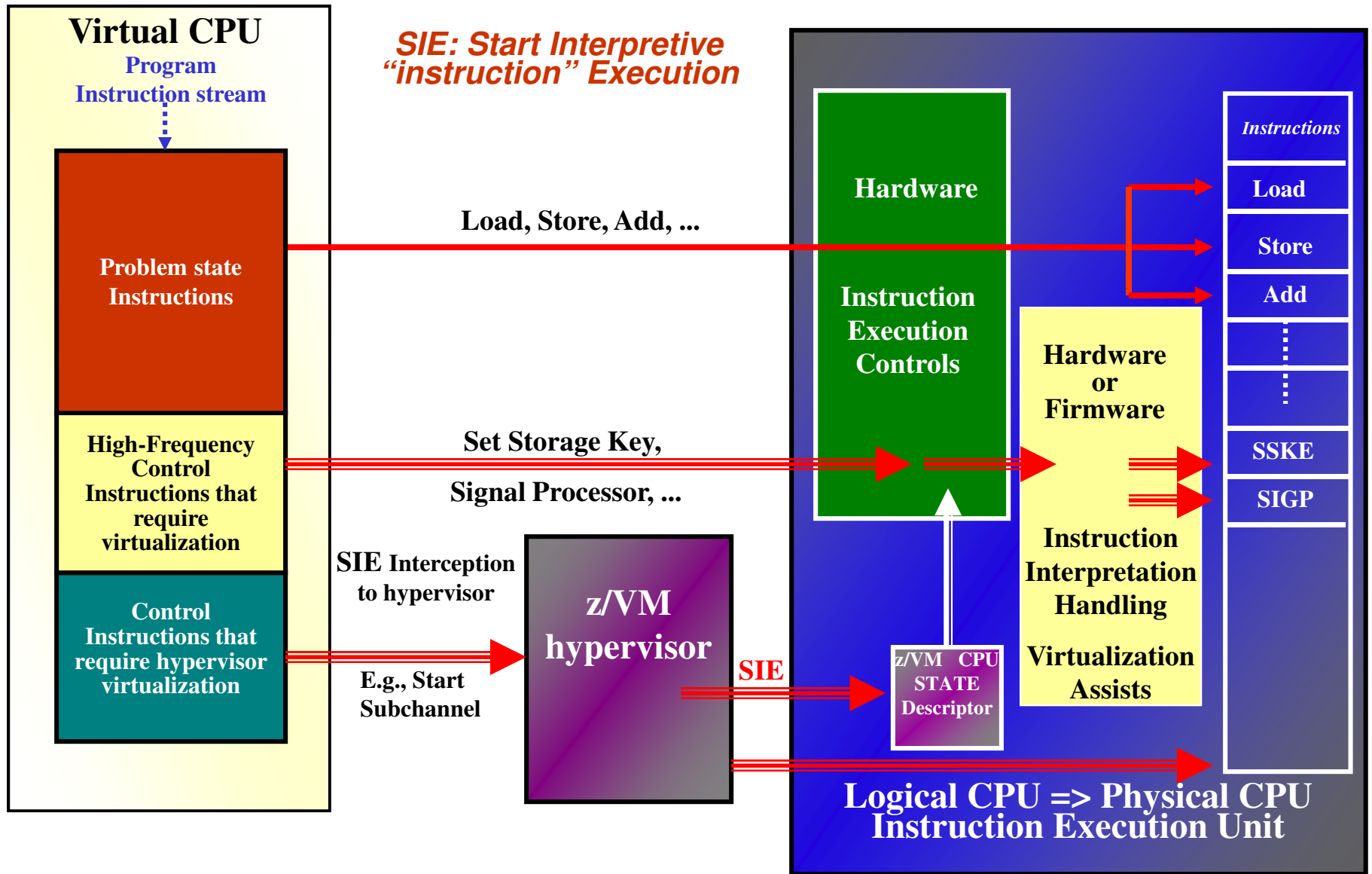

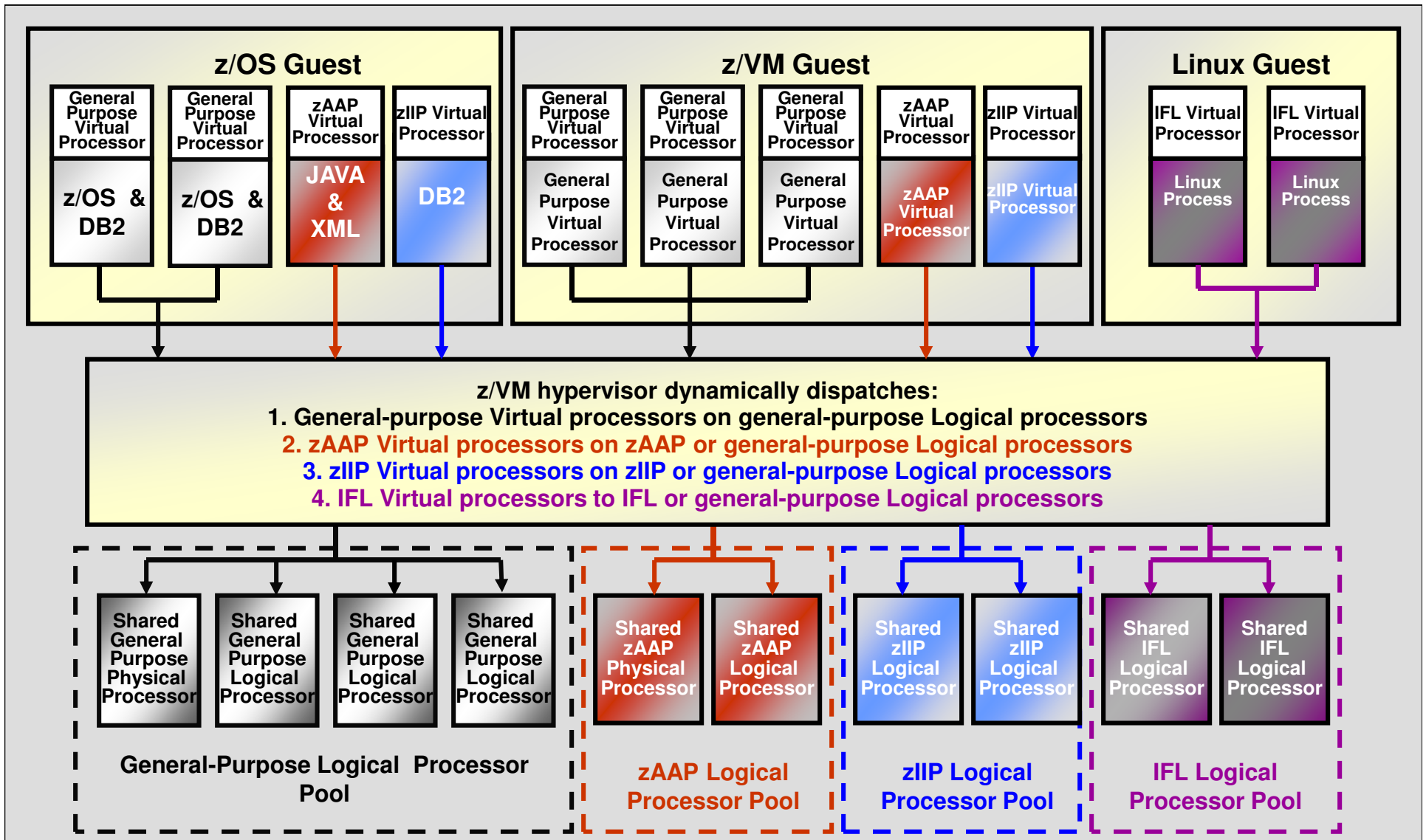

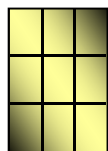
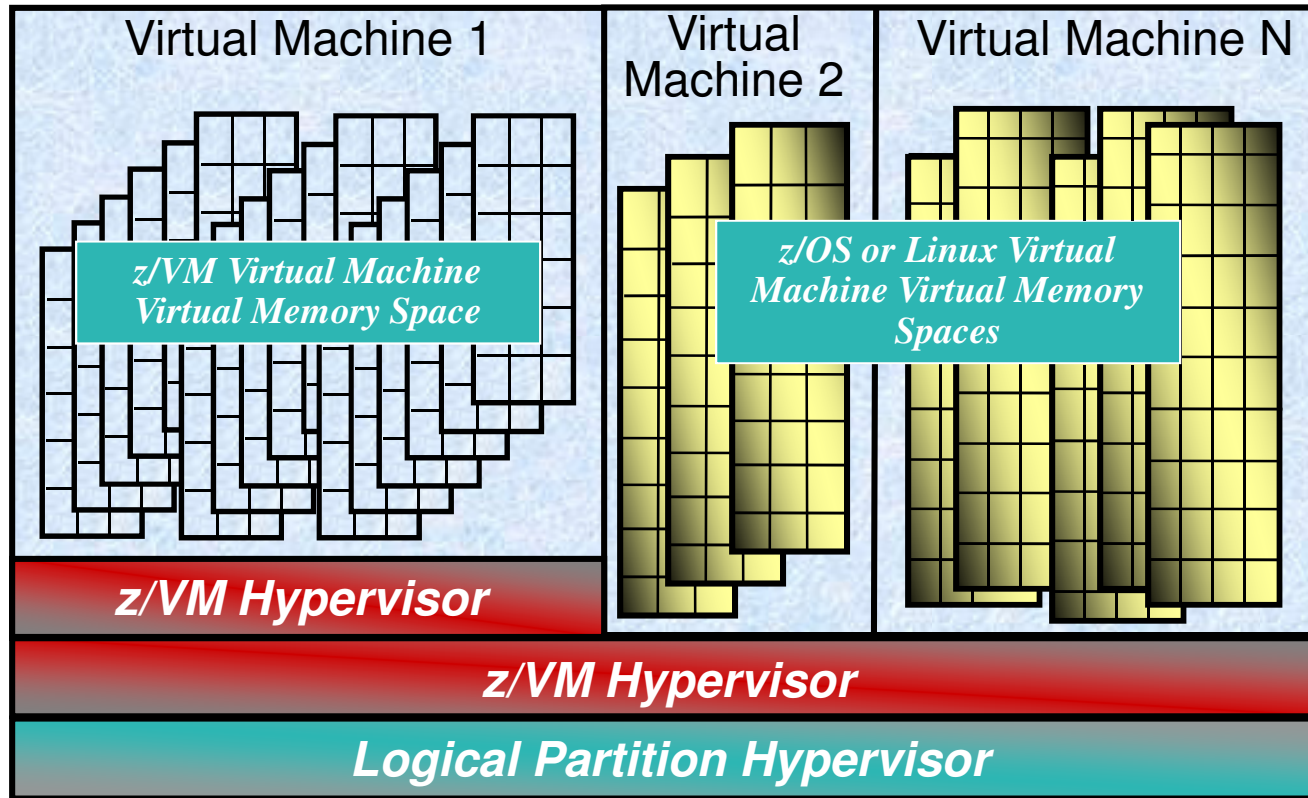

= the guest real memory pages associated with a virtual address space; that is, the sets of dynamically-allocated host virtual memory pages necessary to run a z/OS task or a Linux process



= the guest real memory pages associated with a virtual machine; that is, the sets of dynamically-allocated host virtual memory pages necessary to run a guest operating system in a virtual machine

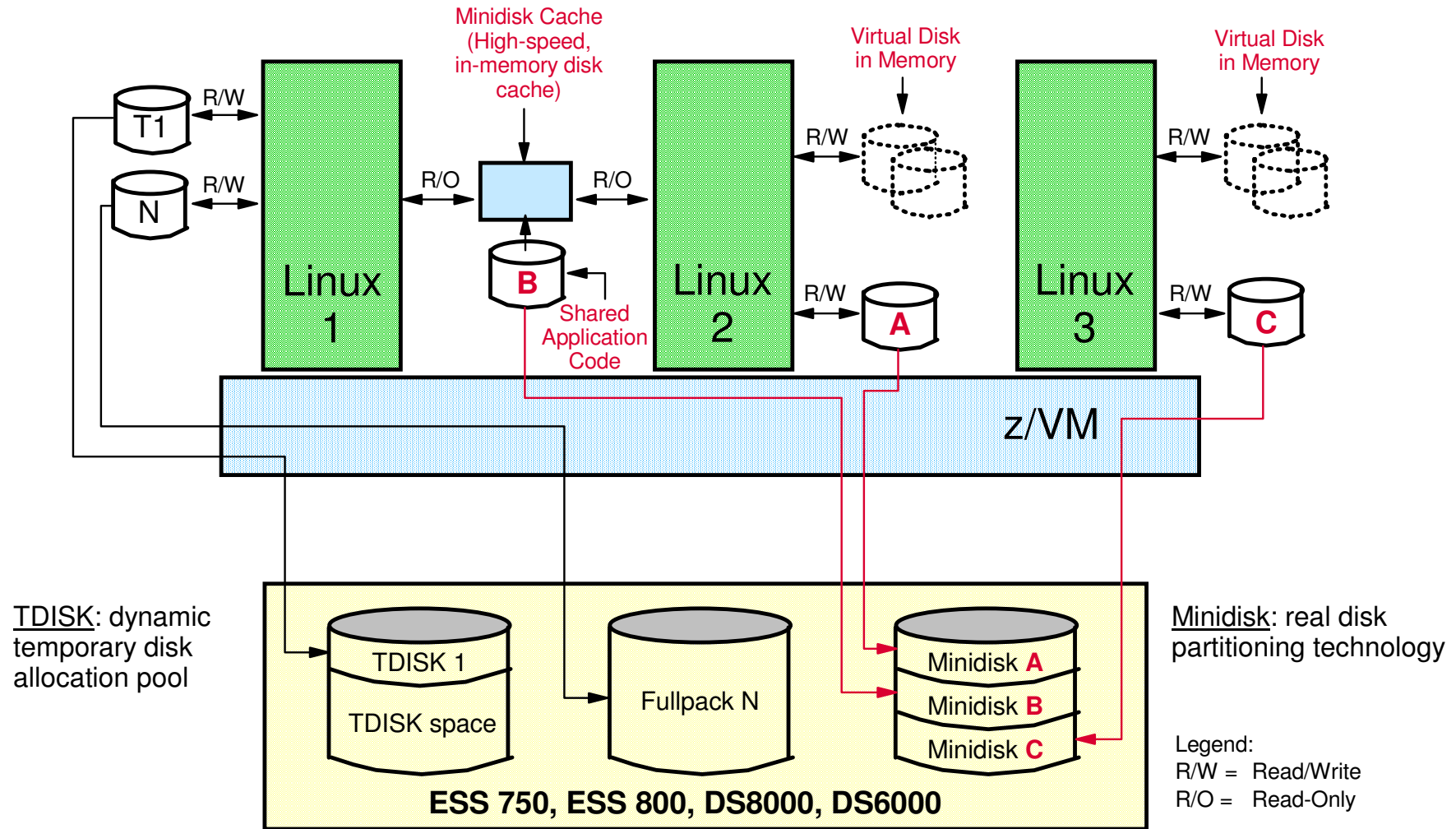

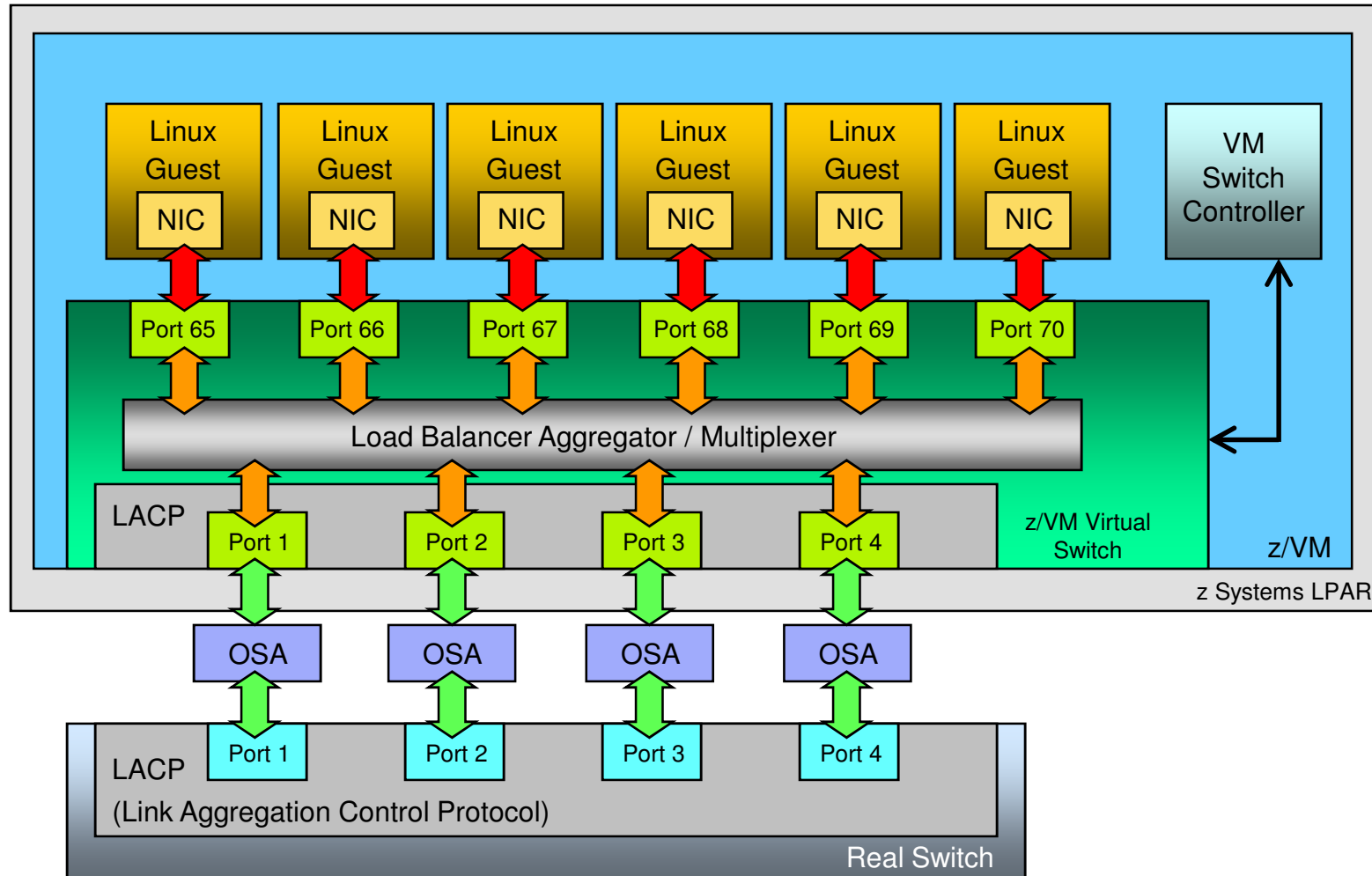

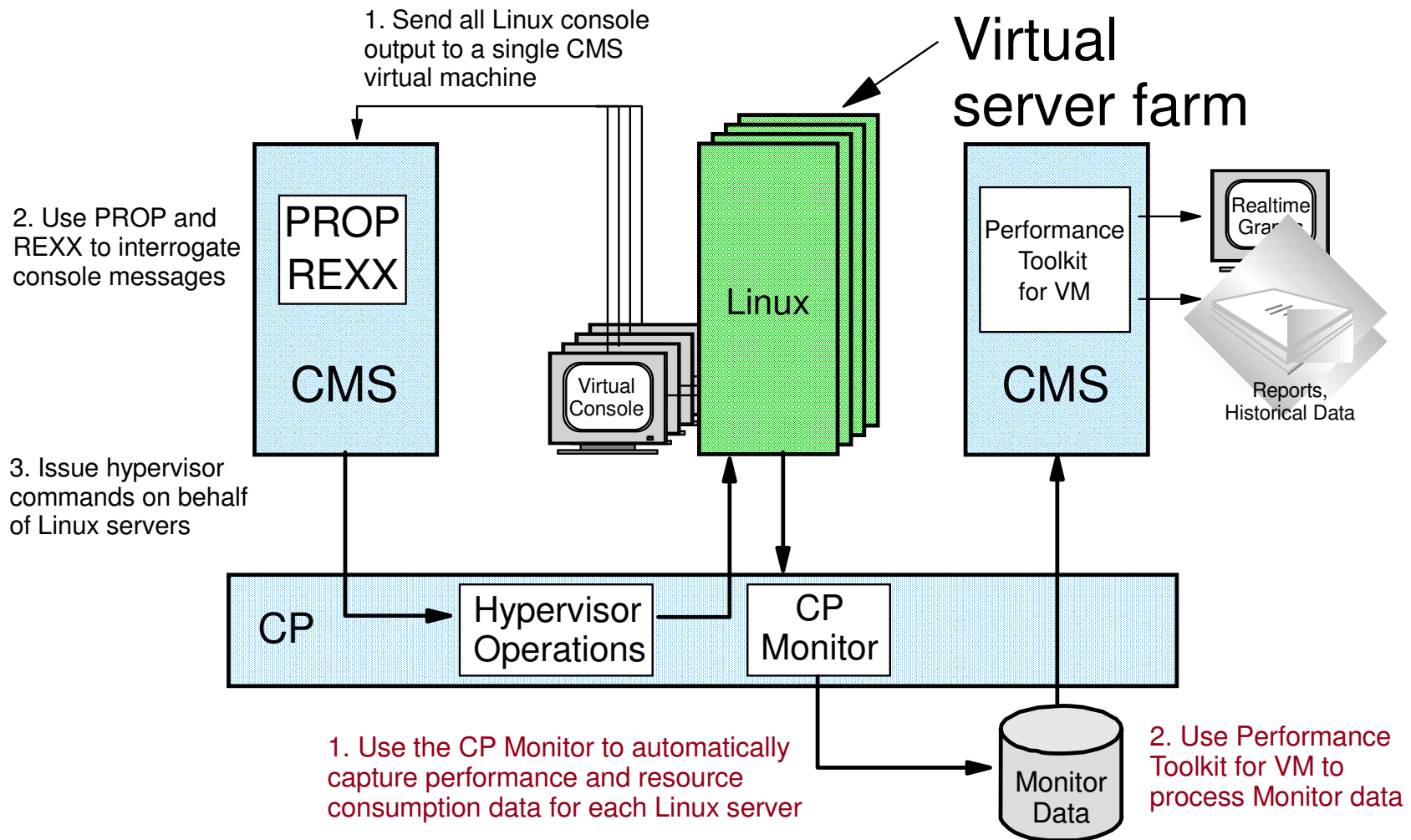

Over 45 years of continual innovation in virtualization

- Refined to support modern business requirements
- Exploiting hardware technology for economical growth

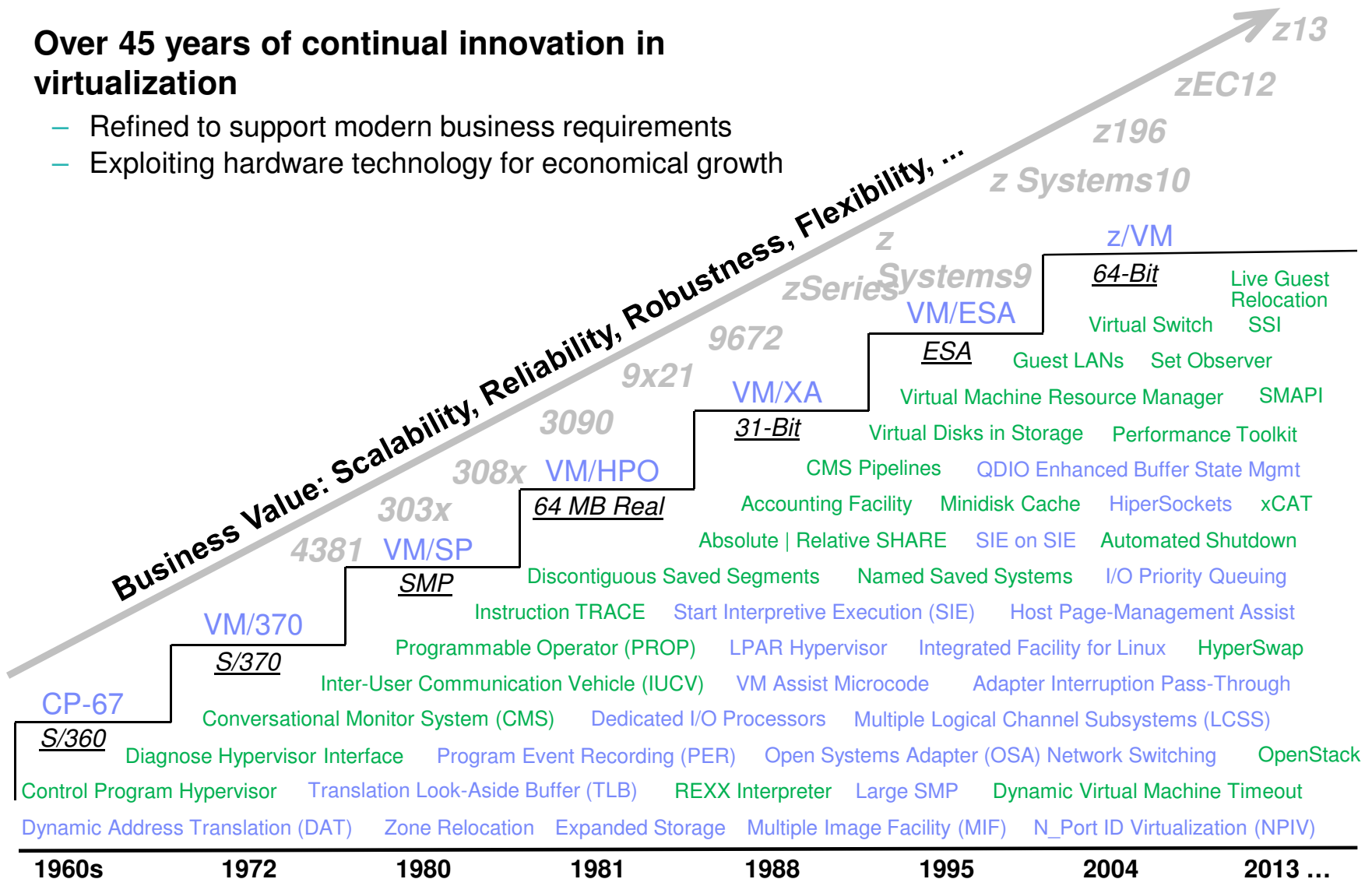

IBM z Systems – a comprehensive and sophisticated suite of virtualization function