

Taking a Look Inside the DFSMSHsm Control Data Sets

Session 10915
Michael E. Friske



Trademarks

The following are trademarks of the IBM Corporation.

DFSMSHsm z/OS

The following is a registered trademark of Merrill Consulting, Inc.

MXG

The following is a registered trademark of SAS Institute, Inc.

SAS

Information in the HDS CDS's

- Reporting
- Diagnosing problems
- Fixing errors
- Recovering “deleted” data

HSM Control Data Sets

- MCDS – Migration Control Data Set
- BCDS – Backup Control Data Set
- OCDS – Offline Control Data Set

MCDS Records

| Record ID | Record Type | Description |
|-----------|-------------|---|
| A | MCA | Alias entry record |
| D | MCD | Data set record |
| N | VAC | JES3 Volume Activity Count record |
| O | MCO | VSAM associations record for VSAM objects |
| S | L2CR | Migration Level 2 Control Record |
| | MCR | Management Control Record |
| | DSR | Daily Statistics Record |
| | MHCR | Multiple HSM Host Control Record |
| | VSR | Volume Statistics Record |
| U | MCU | User record |
| V | MCV | Migration Control Volume record |
| 1 | MC1 | Migration Level 1 free space record |

BCDS Records

| Record ID | Record Type | Description |
|-----------|-------------|---|
| B | MCB | Backup Control data set record |
| C | MCC | Backup version record |
| G | DGN | Dump Generation record |
| L | MCL | Backup changed migrated data set record |
| M | MCM | Move backup version record |
| P | MCP | Backup eligible volume record |
| Q | ABR | Aggregate Backup and Recovery record |
| R | BCR | Backup Control Record |
| | BVR | Backup cycle Volume Record |
| | DCR | Dump Control Record |
| W | DCL | Dump Class Record |
| X | MCT | Backup volume record |
| Y | DVL | Dump volume record |

BCDS Records for Fast Replication

| Record ID | Record Type | Description |
|-----------|-------------|---------------------------------------|
| F | FRB | Fast Replication Backup record |
| I | FRTV | Fast Replication Target Volume record |
| J | FRSV | Fast Replication Source Volume record |
| K | FRD | Fast Replication Dump control block |

OCDS Records

| Record ID | Record Type | Description |
|-----------|-------------|-------------------------------|
| E | TCN | Tape Copy Needed Record |
| T | TTC | Tape Table of Contents record |

MCDS MCD Record – Migrated Data Set Record

| Field Name | Field Length | Field Description | Points to | Usage | Note |
|------------|--------------|--------------------------------|-----------|------------------------|------|
| MCD | 44 | User data set name | | Key of MCD record | |
| MCDVSN | 6 | Volser of migration volume | MCV | Build key of ML MCV | 1 |
| MCDFRVSN | 6 | User volume | MCV | Build key of LO MCV | 1 |
| MCDUCBTY | 4 | Device type of the user volume | | Determine track size | 1 |
| MCDMCANM | 44 | Migration data set name | MCA | Key of MCA record | 2 |
| MCDFBID | 4 | File block ID | CDD | Tape data set position | 3 |
| MCDTERN | 4 | TTOC extension record | TTOC | Relative TTOC record | 4 |

1. This field is required to recall the data set.
2. This field is required to recall the data set from disk (ML1).
3. This field is required to recall the data set from tape (ML2).
4. This is used to improve the performance of recalls.

MCDS MCA Record – Alias Entry Record

| Field Name | Field Length | Field Description | Points to | Usage | Note |
|------------|--------------|---|-----------|-------------------|------|
| MCA | 44 | Migration data set name or VSAM object name (data, index, aix, aix data, aix index, or path name) | | Key of MCA record | 1 |
| MCAINTTP | 1 | Record type flag | | | 2 |
| MCAINTNM | 44 | User data set name | MCD | Key of MCD record | |

1. This record is only required for:
 - Tape RECYCLE
 - RECALL of a VSAM cluster using other than the cluster name
2. Record types:
 - D – Data component
 - I – Index component
 - R – Path
 - G – AIX
 - M – Generated name of the migration data set

MCDS MCO Record – VSAM Association Record

| Field Name | Field Length | Field Description | Points to | Usage | Note |
|------------|--------------|--------------------------|-----------|-------------------|------|
| MCO | 44 | | | Key of MCO record | 1 |
| MCOORGNM | 44 | Cluster name | MCD | Key of MCD record | 2 |
| MCOCDDSN | 44 | Data component name | MCA | Key of MCA record | 2 |
| MCOCIDSN | 44 | Index component name | MCA | Key of MCA record | 2 |
| MCOCPH | 44 | Path name | MCA | Key of MCA record | 2 |
| MCOGDSN | 44 | AIX name | MCA | Key of MCA record | 2 |
| MCOGDDSN | 44 | AIX data component name | MCA | Key of MCA record | 2 |
| MCOGIDSN | 44 | AIX index component name | MCA | Key of MCA record | 2 |
| MCOGPTH | 44 | AIX path name | MCA | Key of MCA record | 2 |

1. The key of the MCO record is the same as the key of the MCA record except the first character is replaced with X'12'.
2. The keys of all the MCA records other than the one chained from the MCD record are the same as the VSAM component names.

BCDS MCB Record – Backup Control Data Set Record

| Field Name | Field Length | Field Description | Points to | Usage | Note |
|------------|--------------|--------------------|-----------|-------------------|------|
| MCB | 44 | User data set name | | Key of MCB record | 1 |
| MCBBDSN | 44 | Backup copy name | MCC | Key of MCC record | 2 |
| MCBBDSN | 44 | Backup copy name | MCC | Key of MCC record | 2 |
| MCBBDSN | 44 | Backup copy name | MCC | Key of MCC record | 2 |

1. This field is required to recover any backup for this data set.
2. This field is required to recover this specific backup version for the user data set.

BCDS MCC Record – Backup Version Record

| Field Name | Field Length | Field Description | Points to | Usage | Note |
|------------|--------------|------------------------------|-----------|------------------------------|------|
| MCC | 44 | Backup copy name | | Key of MCC record | 1 |
| MCCADSN | 44 | User data set name | MCB | Key of MCB record | |
| MCCVSN | 6 | Volser of backup volume | MCT | Used to build the MCT record | 1 |
| MCCGEN | 2 | Backup version number | | Absolute version number | |
| MCCFLGS | 2 | Data set type and other info | | | 2 |
| MCCFRVOL | 6 | User volume | MCV | Used to build the MCV key | 1 |
| MCCFRUCB | 4 | Device type of user volume | | Determine the track size | 1 |
| MCCTERN | 4 | TTOC extension record | TTOC | Relative TTOC ext. | 3 |
| MCCFBID | 4 | File Block ID | CDD | Relative block on tape | 4 |

1. This field is required to recover a backup copy.
2. This field is used to recover the correct data set in the event there is an uncataloged data set.
3. This field is required for recovery of a backup copy from tape.
4. This is a performance enhancement.

MCDS MCV Record – Migration Control Volume Record

| Field Name | Field Length | Field Description | Points to | Usage |
|------------|--------------|---------------------------------|-----------|---------------------|
| MCV | 44 | X'04', then volser, then padded | | Key of MCV record |
| MCVUNIT | 8 | Unit name | | Name used in ADDVOL |
| MCVUCBTY | 4 | Device type of volume | | |

There must be an MCV record for every volume used during the recall.

BCDS MCT Record – Backup Volume Record

| Field Name | Field Length | Field Description | Points to | Usage |
|------------|--------------|---------------------------------|-----------|---------------------|
| MCT | 44 | X'2C', then volser, then padded | | Key of MCT record |
| MCTUNIT | 8 | Unit name | | Name used in ADDVOL |
| MCTFLGS | 2 | SP, UN, or nn and other info | | |

There must be an MCT record for every backup volume used during a recovery operation.

OCDS TTOC Record – Tape Table of Contents

| Field Name | Field Length | Field Description | Points to | Usage | Note |
|------------|--------------|--|------------|--------------------|------|
| TTCKEY | 44 | | | Key of TTOC record | 1 |
| TTCDSN | 44 | Migration or backup copy data set name | MCA or MCC | Key of MCA or MCC | |
| TTCDSN | 44 | Migration or backup copy data set name | MCA or MCC | Key of MCA or MCC | |

- TTOC record key
 - X'32', + SP, UN, dd, or L2, + "-", + volser, + "-", and then a 4-byte sequence number
- TTOC records are not required for RECALL or RECOVER commands.
- TTOC records are required for RECYCLE.

BCDS BVR Record – Backup Cycle Volume Record

| Field Name | Field Length | Field Description | Points to | Usage |
|------------|--------------|---|-----------|----------------------------------|
| BVRKEY | 44 | X'30', + "BVR", + SP, UN, or nn, + "-", + sequence number | | Key of BVR record |
| BVRNVOLS | 2 | Volume count | | Number of volumes in this record |
| BVRVSN | 6 | Volser | | |
| "" | 6 | Volser | | |

BVR records are only necessary for backup volume selection or deletion.

CDD Record

| Field Name | Field Length | Field Description | Points to | Usage | Note |
|------------|--------------|-----------------------------|-----------|------------|------|
| CDDDSN | 44 | Data set name | | | 1 |
| CDDDSCB | 71 | Format 1 DSCB from the VTOC | | | |
| CDDID | 6 | C'*CDD**' | | Eyecatcher | |

- CDDDSN is equal to:
 - Original data set name for non-VSAM migration or backup copy
 - Cluster name for VSAM backup copy
 - Data component for VSAM migration copy
- The CDD record is the first record for every HSM migration or backup copy, and it is never compacted

Record Chains for Migrated Data Set

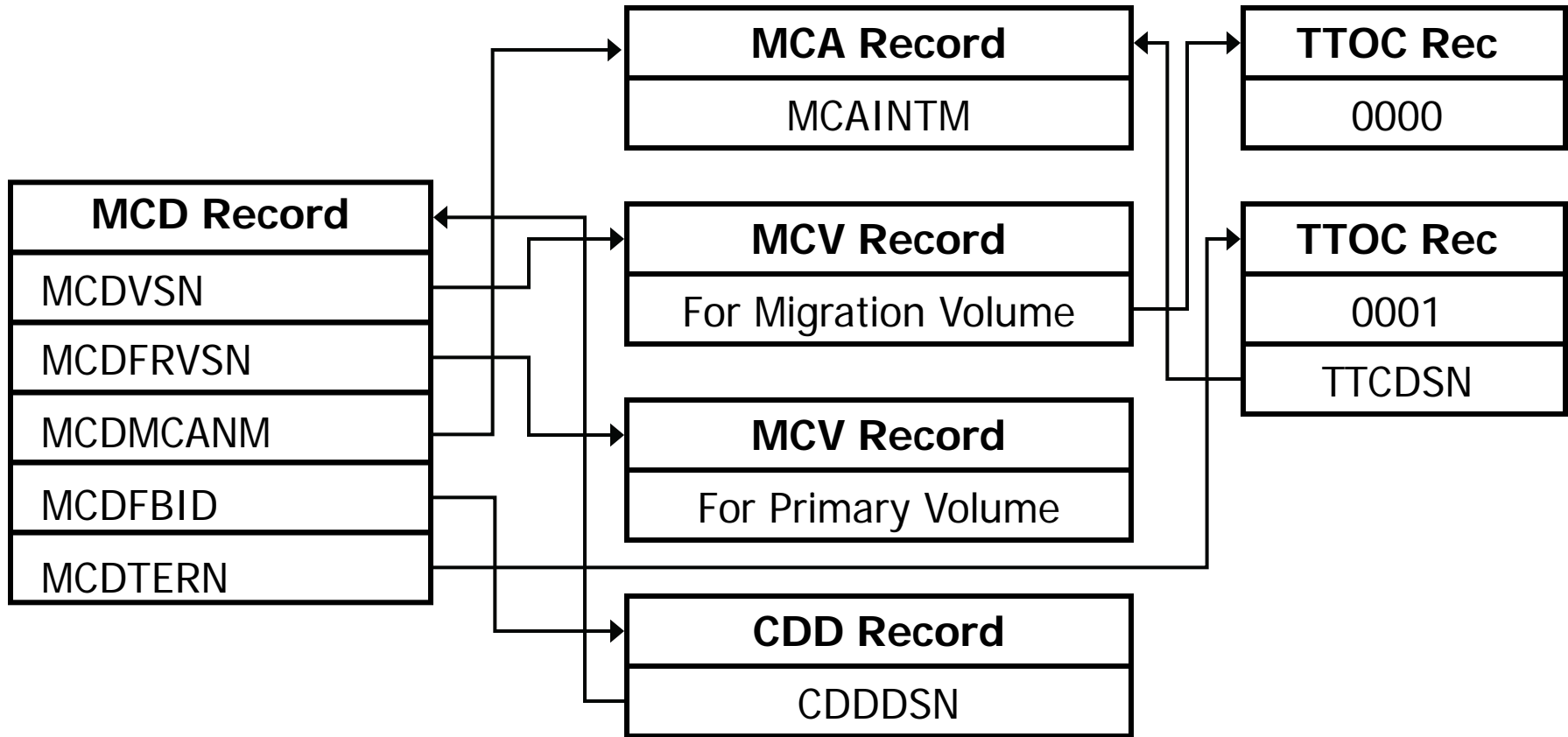

Record Chains for Migrated VSAM Data Sets

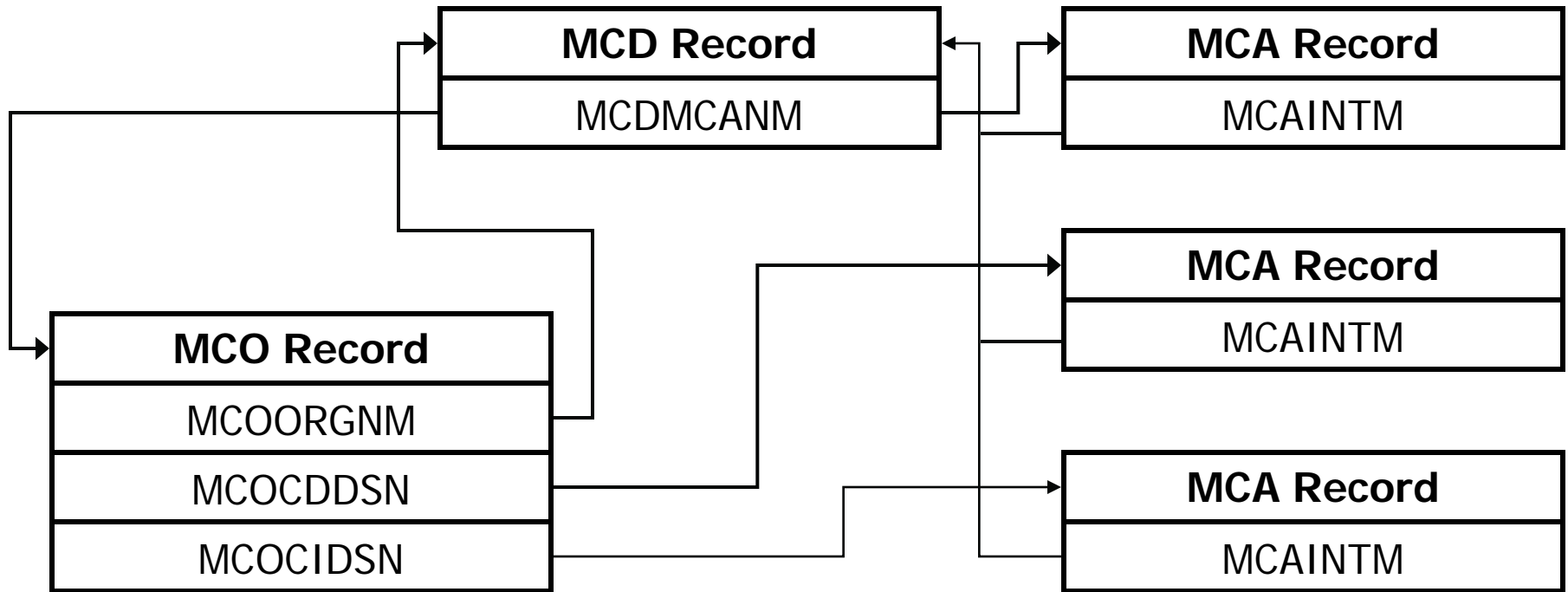

Records Needed to Recall a Migrated Data Set from DASD

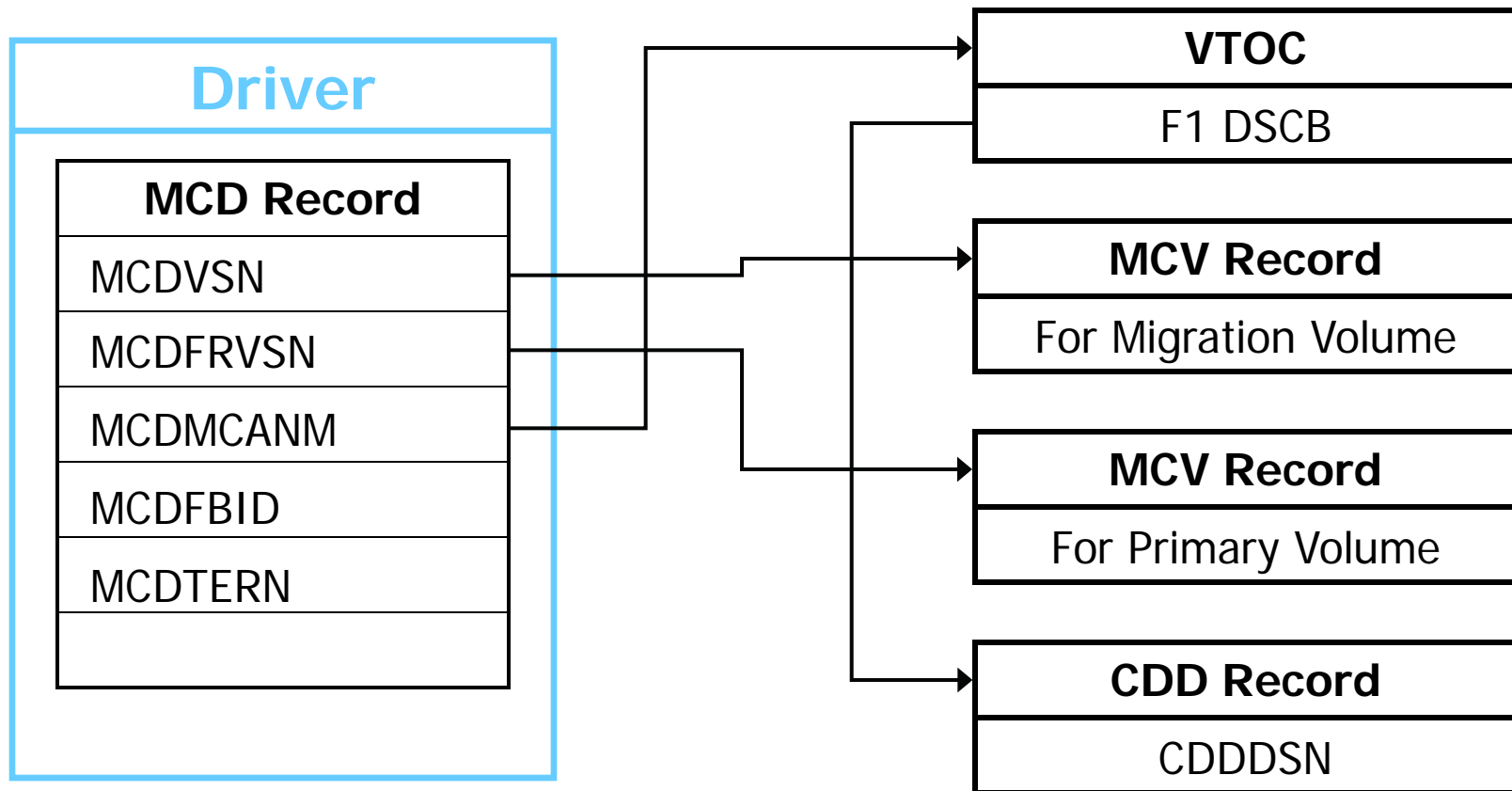

Records Needed to Recall a Migrated Data Set from Tape

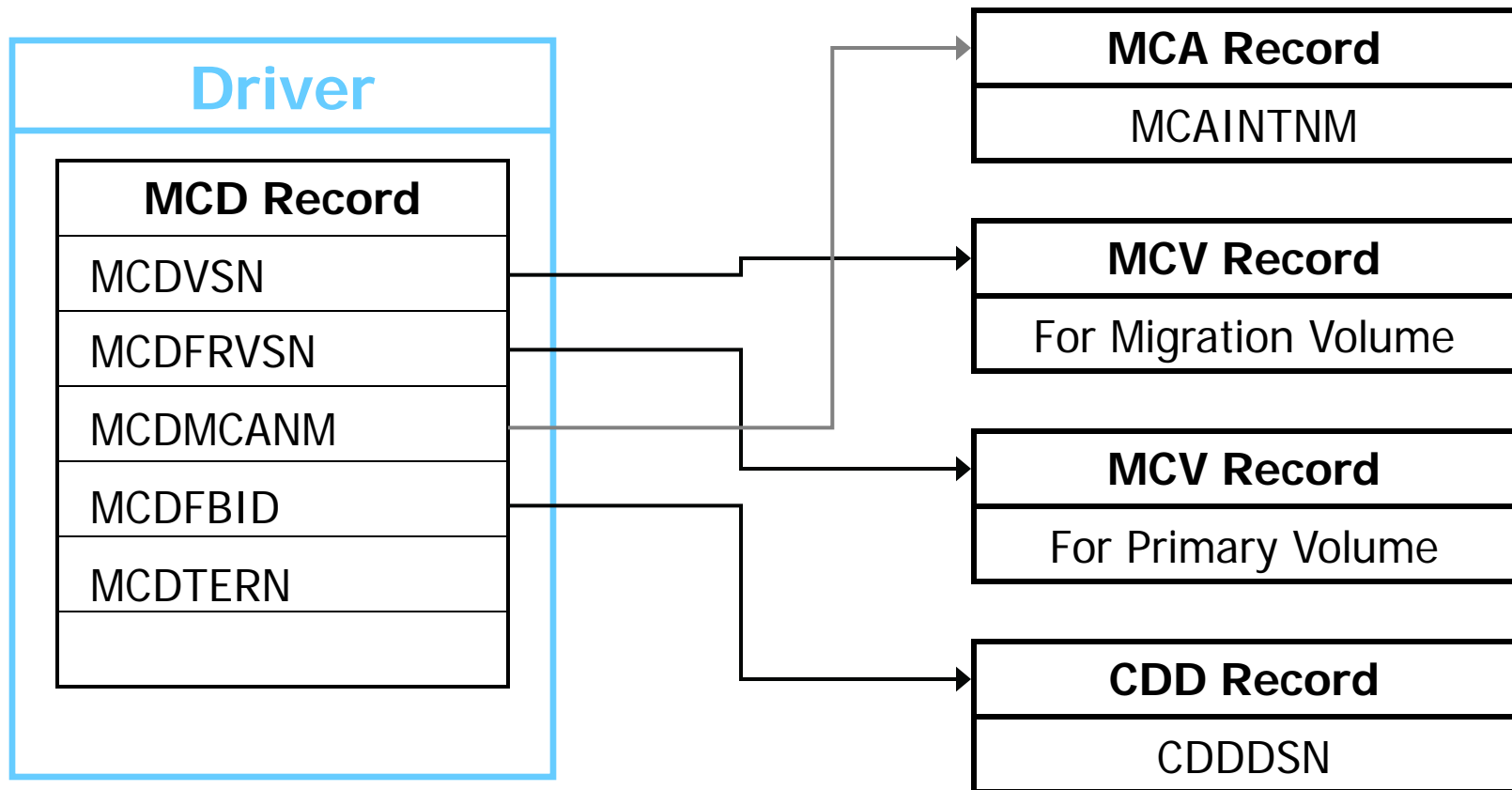

Record Chains for Backup Copies

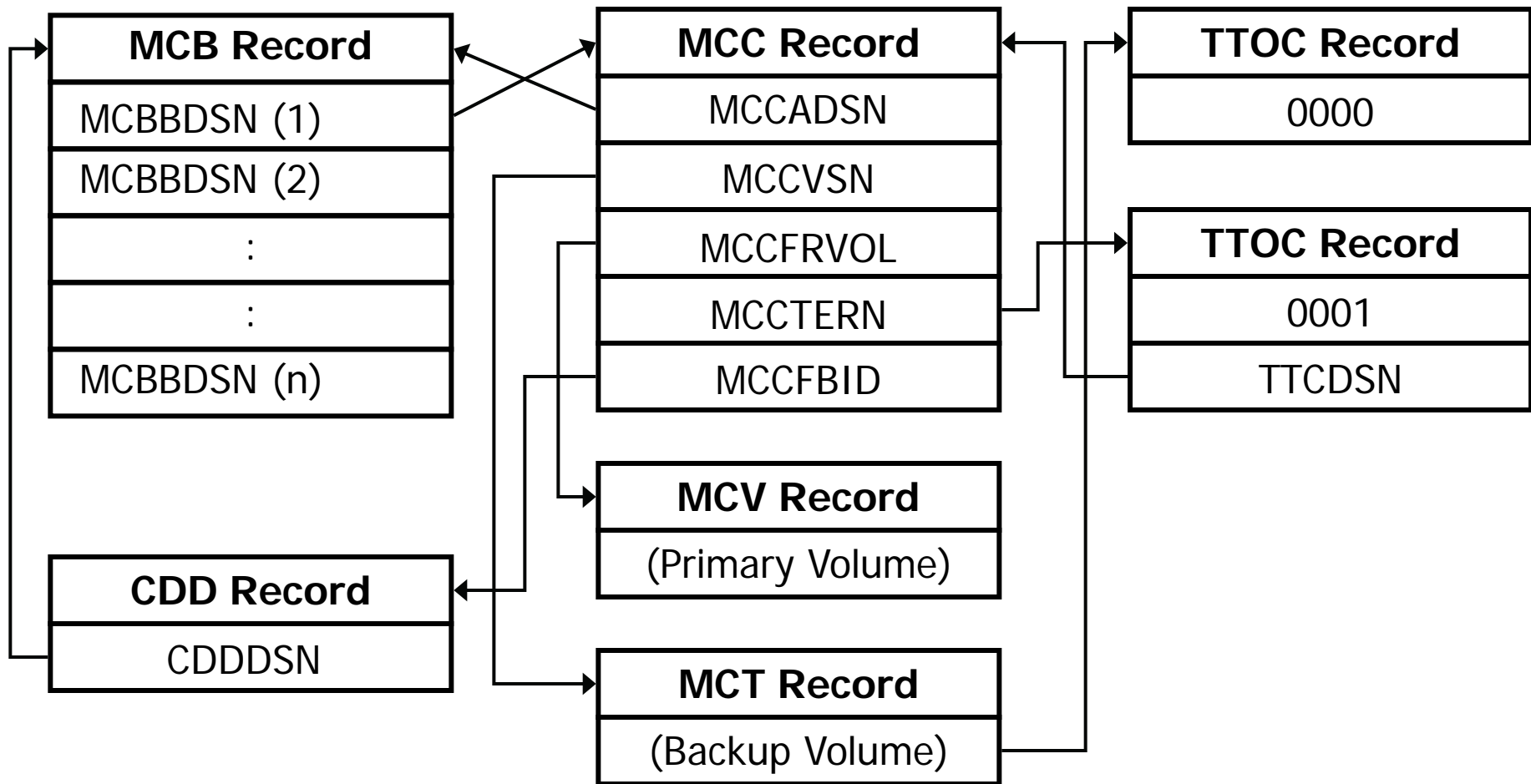

Records Needed to Recover a Backup Copy

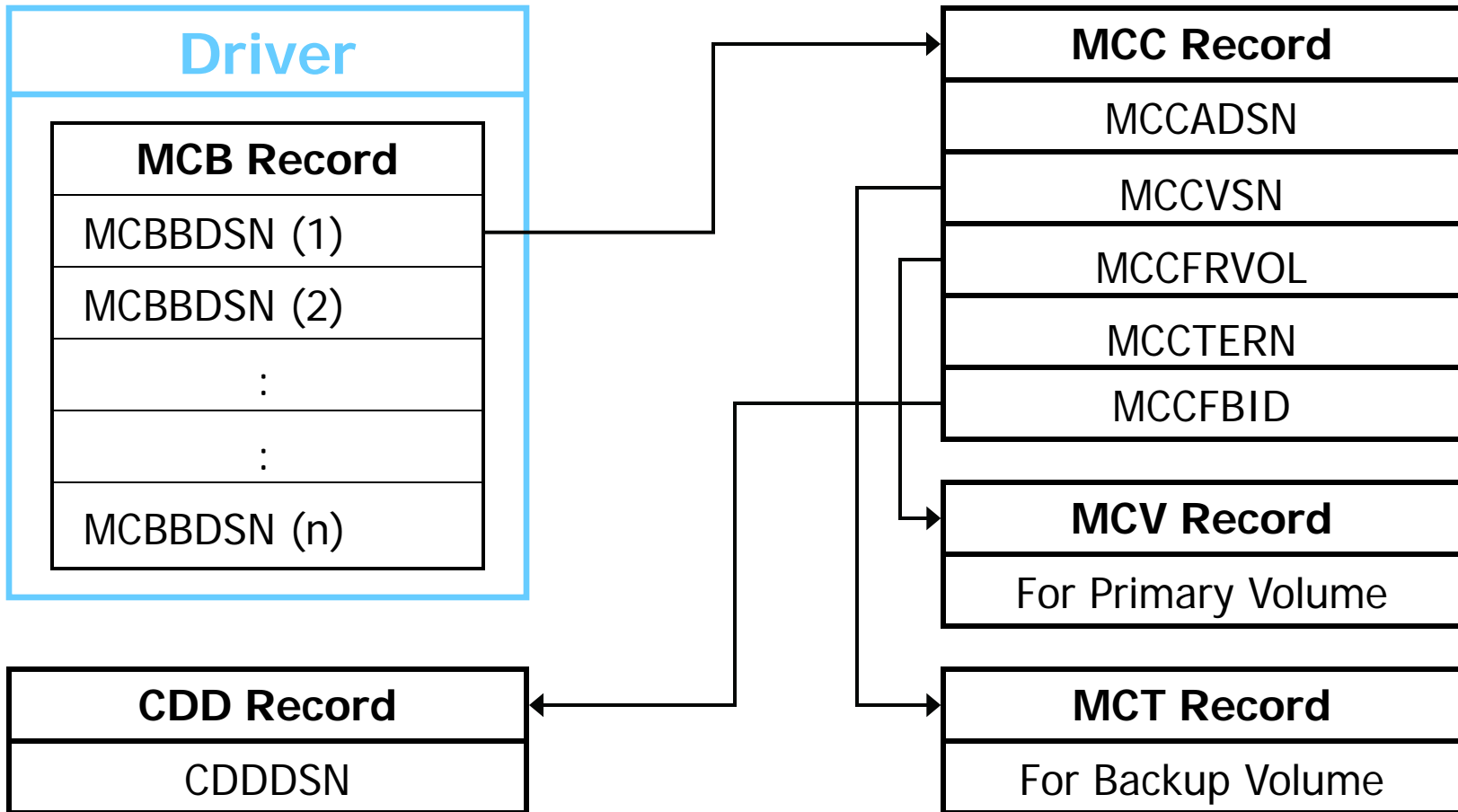

Records Needed for RECYCLE ALL of Migration Volumes

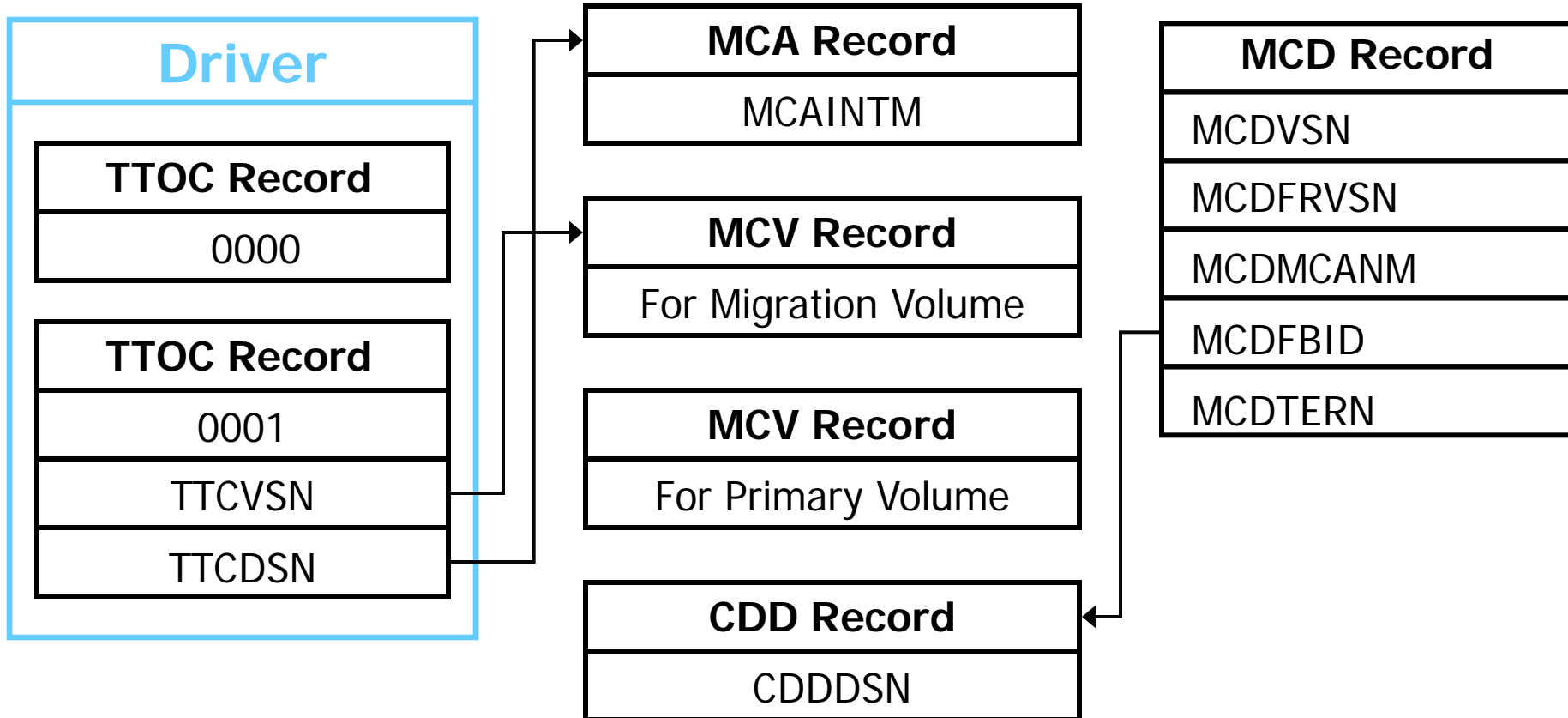

Records Needed for RECYCLE VOLUME of Migration Volumes

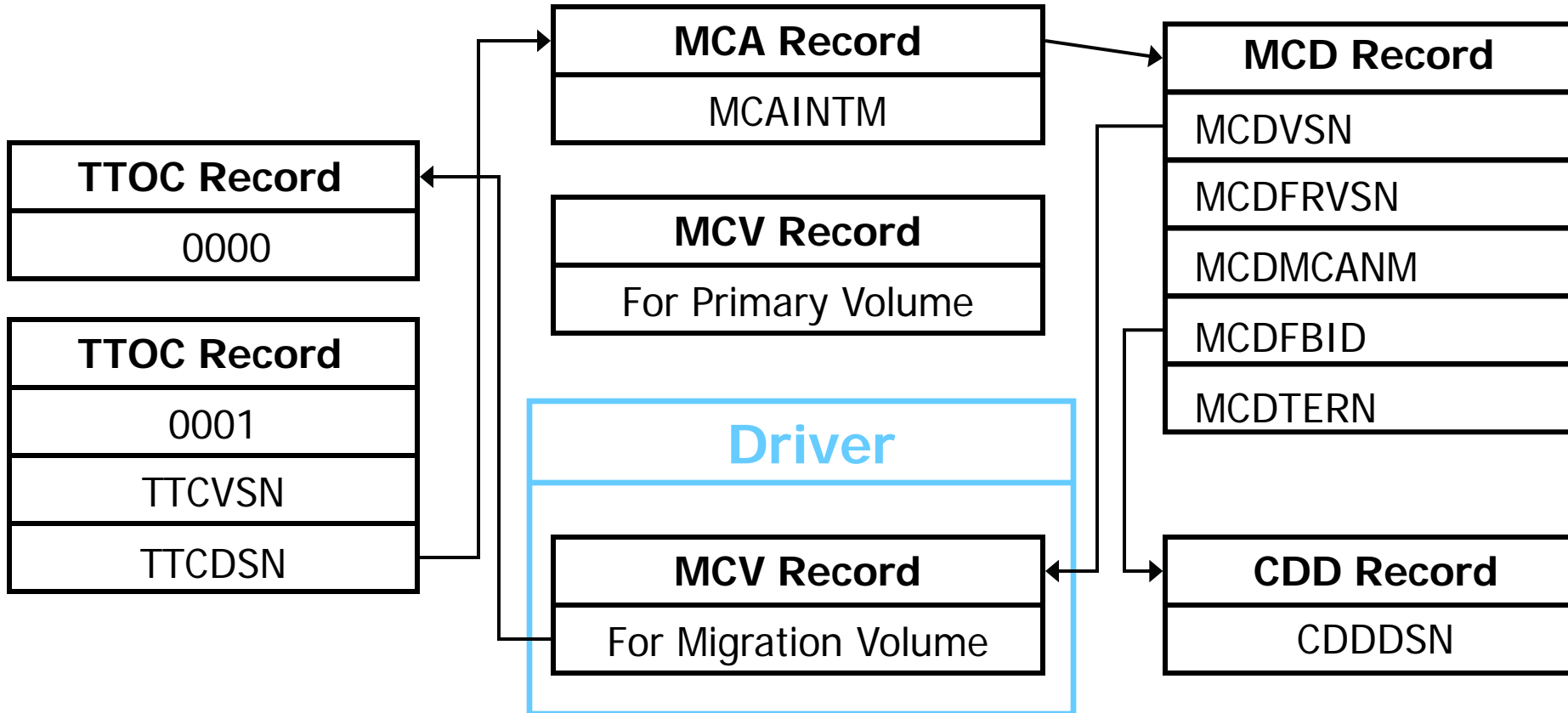

Records Needed for RECYCLE ALL of Backup Volumes

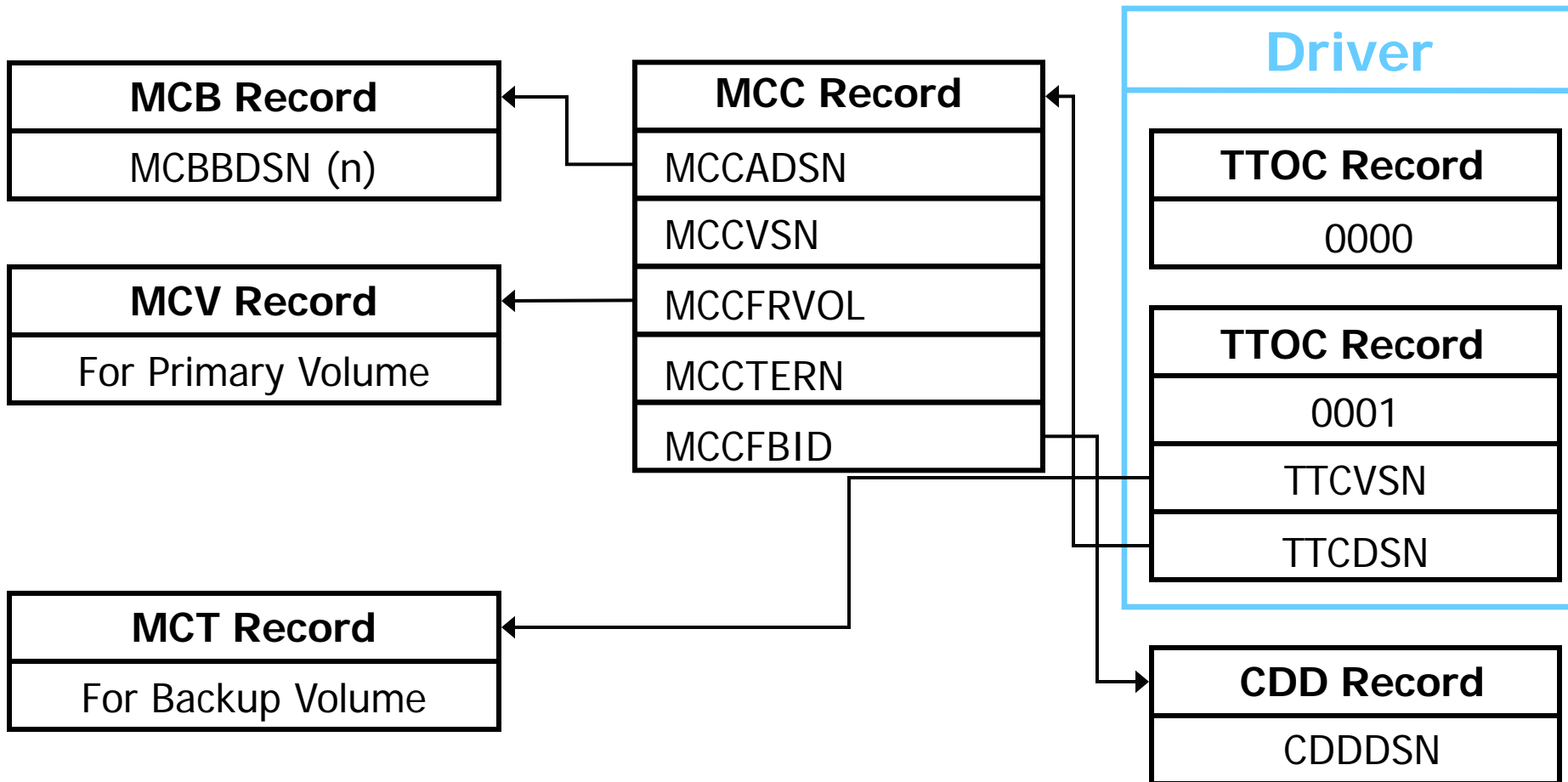

Records Needed for RECYCLE VOLUME of Backup Volumes

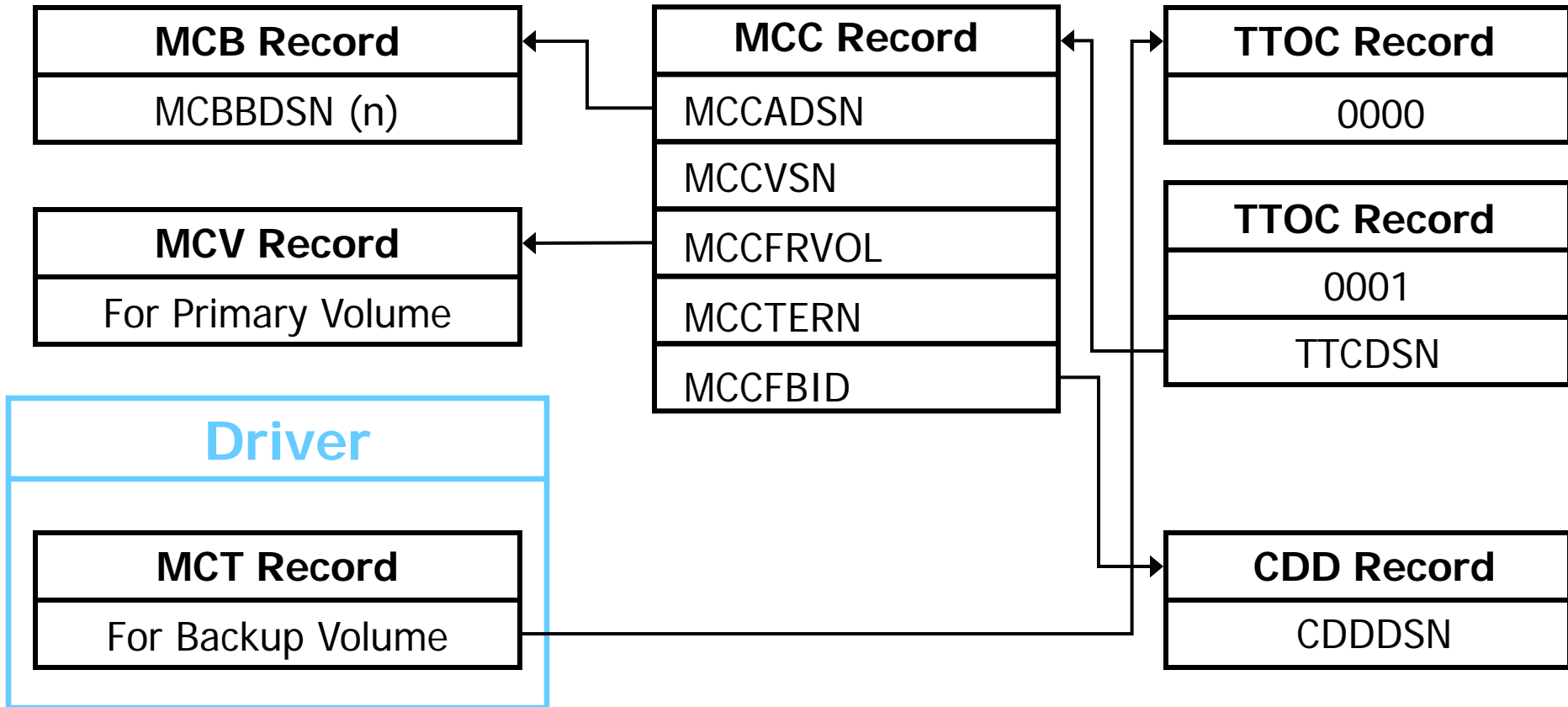

Fixing CDS Records Using the Audit Command

- AUDIT ABARSCONTROLS FIX – Used for fix ABR records
- AUDIT COPYPOOLCONTROLS FIX – Used to fix problems with the Copy Pool records
- AUDIT DATASETCONTROLS FIX – Used to fix problems with the MCDS and/or BCDS records associated with migrated data sets or backup copies
- AUDIT DIRECTORYCONTROLS FIX – Used to compare VTOC or TTOC information with information in MCD and MCC records and to fix discrepancies
- AUDIT MEDIACONTROLS FIX – Used for fix discrepancies between what is on ML1 or ML2 and what HSM has in its CDS
- AUDIT VOLUMECONTROLS FIX – Used to fix volume records in the HSM CDS

Displaying and Fixing CDS Records Using FIXCDS

- HSEND FIXCDS command
 - Displays records (the record header, the first 64 bytes of the record known as the MCK, is not displayed with the FIXCDS command)
 - Changes records
 - Creates records
 - Deletes records
- The syntax of the FIXCDS command is documented in the DFSMSHsm Diagnosis manual

Sample FIXCDS Commands

- HSEND FIXCDS D MYID.JCL.LIB
- HSEND FIXCDS D MYID.JCL.LIB VERIFY(X'06' -
BITS(0..1.....) PATCH(X'06' BITS(1..0..10.)
- HSEND FIXCDS S MCR3 CREATE(64 X'8010' -
LENGTH(512)
- HSEND FIXCDS P TSO012 DELETE
- HSEND FIXCDS T 01-100225-0000 DELETE

FIXCDS D Output

```

MCH= 01D40000 B8AA20D6 6EE05022 B7529397 815D3542
* M O *
+0000 F7F0F0F9 F2F98401 51340000 0102057F 00000000
0102259F 00000000 00000000
*700929 *
+0020 12055592 0102274F 02007FD0 00908000 00000003
0001F3EE 0000000C 00030000
* 3 *
+0040 E3E2D6F0 F0C30A00 C7C5D540 3030200F 11394905
0102259F 78048081 00000000
*TSO00C GEN *
+0060 00000000 00000000 00000000 00000000 00000000
00000000 00000000 00000000
* *
+0080 00000000 00000000 00000000 00000000 00000000
00000000 0000000F C8E2D44B
* HSM.*
+00A0 C8D4C9C7 4BE3F0F3 F1F8F1F1 4BC1F0F5 F7F9F6F1
4BD3C2C9 4BD1F2F2 F8F94040
*HMIG.T031811.A057961.LBI.J2289 *
+00C0 40404040 40404040 00000000 00000000 8E00C613
00000000 00000002 F0F0F0F4
* F 0004*
+00E0 00130000 00004040 40404040 40404040 40404040
40404040 40404040 40404040
* *
+0100 40404040 0006D5D6 D9D4C1D3 40404040 40404040
40404040 40404040 40404040
* NORMAL *
+0120 40404040 0005E3C5 E2E3F240 40404040 40404040
40404040 40404040 40404040
* TEST2 *
+0140 40404040 B73FFD4A 5BF0F487 00800000 00000000
00000000 00000000 00000000

```

Useful FIXCDS Commands to Recover from System Crashes

- To turn off the system identifier for a TTOC record
 - `FIXCDS T L2-900123-000 VERIFY(X'00' X'F4') PATCH(X'00' X'00')`
- To turn off the “volume in-use flag” for an ML2 volume
 - `FIXCDS V 900123 PATCH(X'09' BITS(...0....))`
 - `FIXCDS V 900123 VERIFY(X'58' X'F4') PATCH (X'58' X'00')`
- To turn off the “SDSP in-use flags”
 - `FIXCDS V ML1008 VERIFY(X'59' BITS(....10..)) PATCH(X'59' BITS(....00..))`
 - `FIXCDS V ML1008 VERIFY(X'59' BITS(....01..)) PATCH(X'59' BITS(....00..))`

Other Volume In-use Flags in the MCV record

- MCVFCOPY – Volume in-use by TAPECOPY
- MCVFSELD – Tape volume in-use
- MCVFMIGD – Volume in-use by data set migration
- MCVFMIGV – Volume in-use by volume migration
- MCVFRECL – Volume in-use by recall
- MCVFRCYS – Volume in-use as input to RECYCLE
- MCVFRCYT – Volume in-use as output to RECYCLE
- MCVFDBAU – Volume in-use by DBA
- MCVFAUD – Volume in-use by AUDIT
- MCV_ARECOVER – Volume in-use by ARECOVER
- MCV_ABACKUP – Volume in-use by ABACKUP

Recall a Previously Deleted ML2 Migrated Data Set

- Issue a “DEFINE NONVSAM” command to catalog the data set to MIGRAT
- Use the “FIXCDS D dsn DISPLAY” command to determine if a “D” record exists
 - “D” record exists – Issue the “FIXCDS D dsn ASSIGNEDBIT(ON)” command
 - “D” record does not exist – Issue the “AUDIT MEDCTL VOLUMES(ml2vol) FIX” command
- Recall the data set

Recovery Scenarios

This and many other recovery scenarios can be found in the DFSSMShsm Storage Administration manual (SC35-0421)

- Damaged CDS, full journal
- Damaged journal, undamaged CDS
- Full journal, undamaged CDS
- Structurally damaged CDS, missing journal records
- Time sequence gaps in CDS records, journal records also missing
- Overwritten migration tape
- Overwritten backup tape
- Damaged ML1 volumes
- Reestablish access to previously deleted migrated data sets (no backup exists, ML2 only)
- Correcting errors within the common recall queue
- Recovering a deleted ML1 data set without a backup

To Create a Volume Record

- Issue the appropriate ADDVOL command
 - ADDVOL PRIMARY creates an MCV record
 - ADDVOL MIGRATION creates an MCV record
 - ADDVOL BACKUP creates an MCT record
 - ADDVOL DUMP creates a DVL record

Other Methods To Read Information from the HSM CDS's

- DCOLLECT
 - Specify MIGRATEDATA to obtain information from the MCD records about migrated data sets
 - Specify BACKUPDATA to obtain information from the MCB and MCC records about backup data
 - Specify CAPPLANDATA to obtain information from the MCV and TTOC records
- SORT
- SAS
- REXX

Sample SORT Job Reading the BCDS

```
//STEP001 EXEC PGM=SORT
//SYSOUT DD SYSOUT=*
//SORTIN DD DSN=HSM.BCDS,DISP=SHR,AMP='BUFND=50'
//SORTOUT DD DSN=HSM.TEMP.VOLRPT.V220225,DISP=(NEW,CATLG),
//
//          AVGREC=K,SPACE=(440,(4,1),RLSE),
//          DSORG=PS,RECFM=VB,LRECL=2048,BLKSIZE=0
//SYSIN DD *
SORT FIELDS=(COPY)
INCLUDE COND=(51,1,BI,EQ,X'24',AND,113,6,CH,EQ,C'220225')
```

Sample SAS Job to Read the BCDS

```
//STEP001 EXEC SAS
//SYSOUT DD SYSOUT=*
//INBCDS DD DSN=HSM.BCDS,DISP=SHR,AMP='BUFND=50'
//COMMANDS DD DSN=HSM.TEMP.HBDELETE,DISP=(NEW,CATLG),
//          AVGREC=K,SPACE=(80,(4,1),RLSE),
//          DSORG=PS,RECFM=FB,LRECL=80,BLKSIZE=0
//SYSIN DD *
DATA CDSIN;
  INFILE INBCDS;
  INPUT @1 MCK $44.
        @47 MCKTYPE $CHAR1. @;
  IF MCKTYPE='24'X;
    INPUT @65 USERDSN $44.
          @109 BKUPVOL $6.
          @155 ORIGVOL $6.;
    IF BKUPVOL='220225';
  QUOTEDSN="( ' " || TRIM(USERDSN) || " ' )";
  FILE COMMANDS;
  PUT @1 'HSEND BDELETE ' @16 QUOTEDSN @62 '- ' /
      @3 'FROMVOL(' @11 ORIGVOL @17 ')';
```

Sample SAS Job to Read the MCDS, Part 1

```
//STEP010 EXEC SAS
//INMCDS DD DSN=HSM.PROD.MCDS,DISP=SHR,AMP='BUFND=18'
//SYSIN DD *
DATA MCDS;
  INFILE INMCDS;
  INPUT @47 MCDSTYPE $CHAR1. @;
  IF MCDSTYPE='00'X;
  INPUT @71 MCDSFLAG $CHAR1. @;
  IF MCDSFLAG='1..0....'B;
  INPUT @1 DSNAME $44.
        @65 MIGVOL $6.
        @117 USEDSP PIB4.
        @155 LVLFLAG $CHAR1.
        @291 MCDFLGS2 $CHAR1.;
```

Sample SAS Job to Read the MCDS, Part 2

```
IF MCDFLGS2 = '.....1.'B THEN USERSIZE=USEDSP*1024;
  ELSE USERSIZE=USEDSP;
SELECT;
  WHEN (LVLFLAG='1.....'B)
    MLEVEL='2';
  WHEN (LVLFLAG='..1.....'B)
    MLEVEL='1';
  OTHERWISE
    MLEVEL='U';
END;
HLQ=SCAN(DSNAME,1, '. ');
PROC SORT;
  BY HLQ MLEVEL;
PROC SUMMARY;
  BY HLQ MLEVEL;
  VAR USERSIZE;
  OUTPUT OUT=TOTHLQ SUM=USERSIZE;
```

Sample SAS Job to Read the MCDS, Part 3

```
PROC PRINT SPLIT='*' UNIFORM;  
  VAR HLQ MLEVEL _FREQ_ USERSIZE;  
  SUM USERSIZE;  
  TITLE1 'MIGRATED DATA BY HIGH LEVEL QUALIFIER';  
  LABEL HLQ=HIGH*LEVEL*QUALIFIER  
         _FREQ_=TOTAL*DATA*SETS  
         MLEVEL=MIGRATION*LEVEL  
         USERSIZE=USED*SPACE;  
  FORMAT _FREQ_ COMMA11. ;  
  FORMAT USERSIZE COMMA19. ;
```

Formatting DCOLLECT Data

- Use MXG from Merrill Consultants, Inc
 - <http://www.mxg.com>
- Use Your Own SAS program
- Use a REXX program
 - Sample in SYS1.SAMPLIB(ARCTOOLS)
 - File #206 at <http://www.cbttape.org/cbtdowns.htm>

Recommended Documentation

- DFSMSHsm Data Areas (Licensed Manual)
- DFSMSHsm Diagnosis
- DFSMSHsm Storage Administration

Summary



- Knowing what records are in the HSM CDS's and how they relate to each other can speed up diagnosing and fixing problems
- There is a wealth of information in the HSM CDS's that can be used for a variety of purposes