

# Hitachi Virtual Storage Platform Update

William Smith  
Hitachi Data Systems (HDS)

Tuesday, August 13, 2013  
Session Number 13978





- Virtual Storage Platform – Quick Technology Update

Storage Virtualization in the Mainframe Environment

Dynamic Provisioning – Mainframe Environment

Dynamic Tiering – Mainframe Environment

Virtual Storage Platform (VSP) – Other NEW Features

Summary

# Virtual Storage Platform - Architecture

- 5<sup>th</sup> generation multi-dimensional internal crossbar switch
- Native 6G SAS backend
- 192 x FC, 96 x FICON / FCoE
- Independent Scale up, scale out, scale deep growth path
- 1TB Global Cache
- 3<sup>rd</sup> generation imbedded virtualization (Open Systems and Mainframe)
- Granular non-disruptive upgrade paths
- 100% non-disruptive maintenance

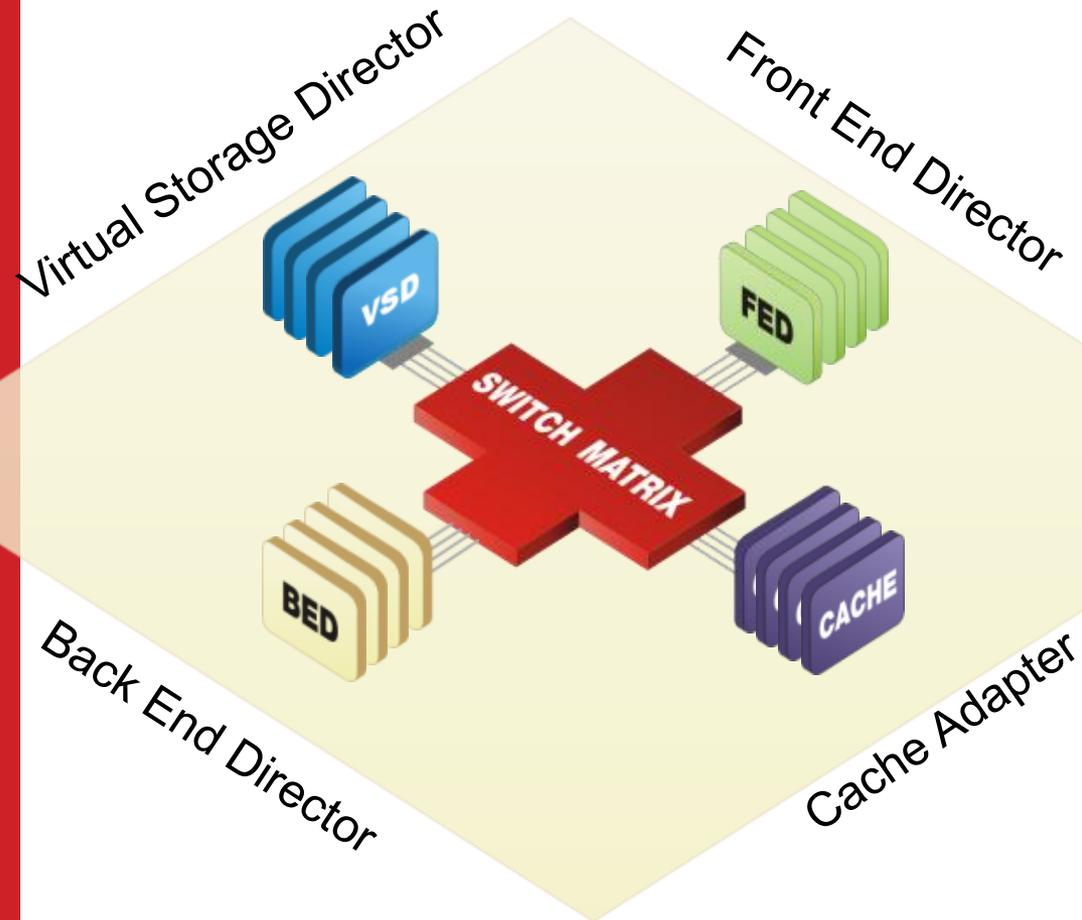

# Encryption Support Updates

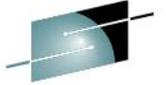

- All Virtual Storage Platforms are encryption capable
  - Every BED has an encryption capability built in
  - Needs to be enabled by software license key
- New encryption mode of operations
  - XTS-AES 256 bit encryption
- Expanded key support
  - 32 keys per array
  - Encryption as access control

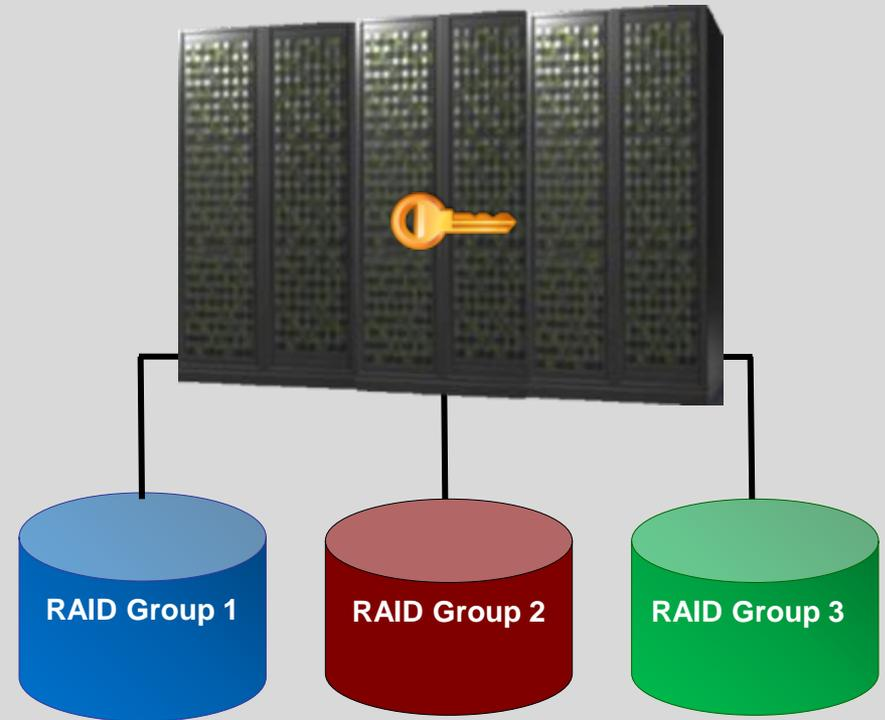

# Virtual Storage Platform



## Capacity

2.5 PB of Internal Storage  
255 PB of virtualized heterogeneous storage  
1280 3.5" drives or 2048 2.5" drives or a combination of both sizes  
65,536 logical devices (LDEV)

## Drive Types

High Performance SSD flash drives  
SAS drives 15K (2.5")  
SAS drives 10K (2.5")  
SAS drives (3.5") - Nearline

## Connectivity (ports)

192 Fibre Channel  
192 FICON  
96 FCoE



# Hitachi Virtual Storage Platform Rack Structure

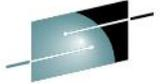

The maximum number of racks is 6:  
2 control chassis and 16 drive chassis

	1 control chassis	2 control chassis
HDD (2.5")	0 - 1,024	0 - 2,048
HDD (3.5")	0 - 640	0 - 1,280
Ports	16 - 96	16 - 192
Cache	Up to 512GB	Up to 1,024GB

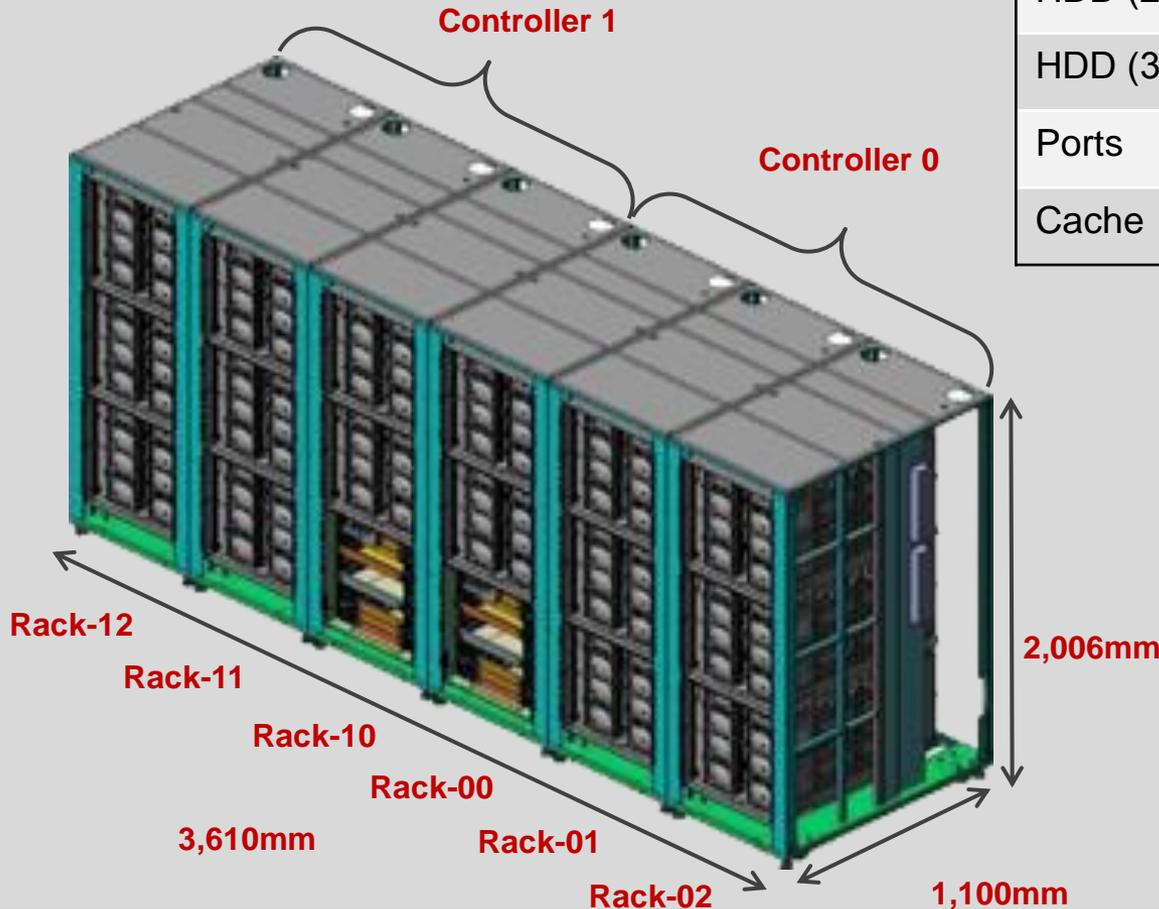

# VSP: Flexible Building Block

- **Hitachi 19" rack**
  - Front to back cooling
  - Up to 6 racks
- **Dense packaging**
  - 13u x 19 inch
  - 80 x 3.5in drives
  - 128 x 2.5in drives
  - SSD and SAS
- **Power and cooling**
  - 48% less power than equivalent capacity Universal Storage Platform® V

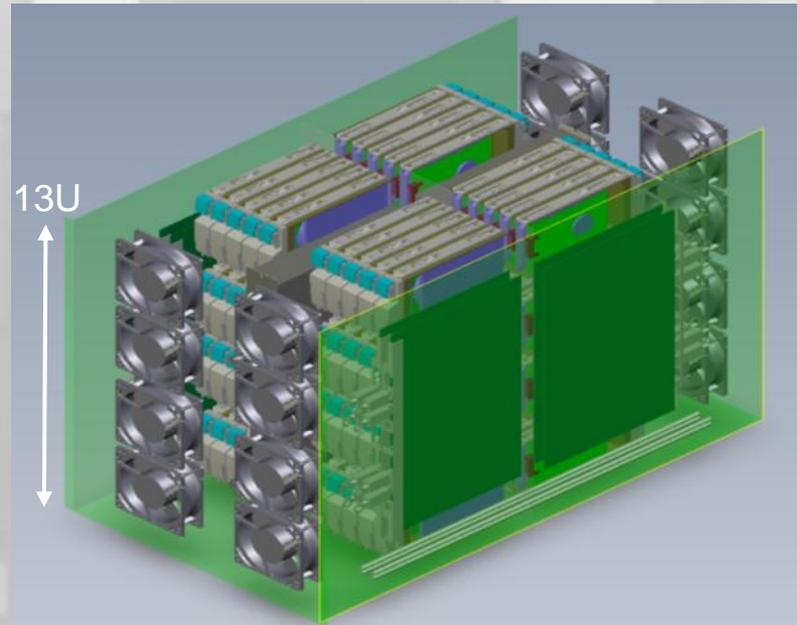

# Comparison: Universal Storage Platform V Fibre Channel Loops vs. Virtual Storage Platform SAS

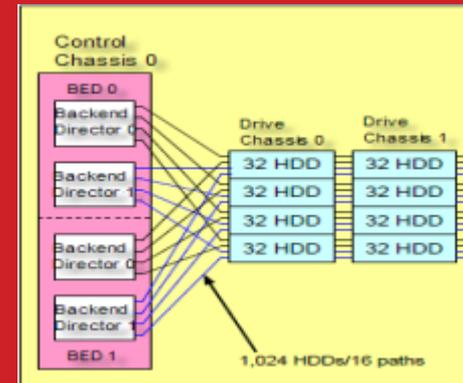
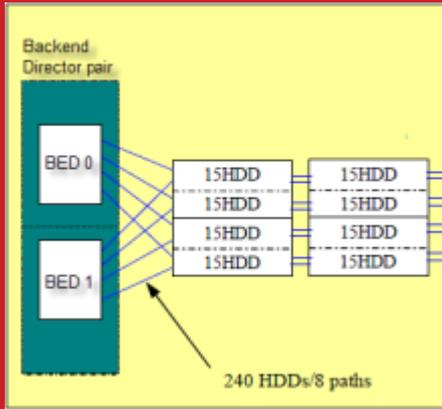
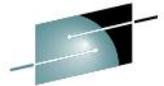

- **Universal Storage Platform V with 64 Fibre Channel (FC) loops 4 FC loops per controller**
  - 4 FC loops per back end director
    - Half duplex arbitrated loops
    - 32 FC loops pair at 4 Gb/s

- **Virtual Storage Platform with 64 SAS links**
  - 8 SAS paths per back end director blade
    - 32 full duplex links per control chassis
    - 64 SAS links at 6 Gb/s
  - Chassis are connected point-to-point
    - Intermix of Flash, SAS and NL SAS

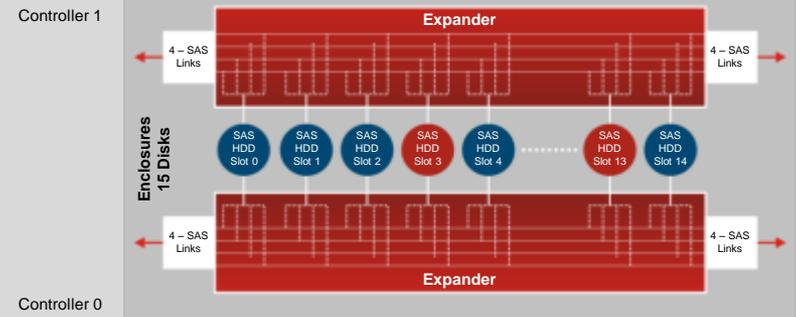
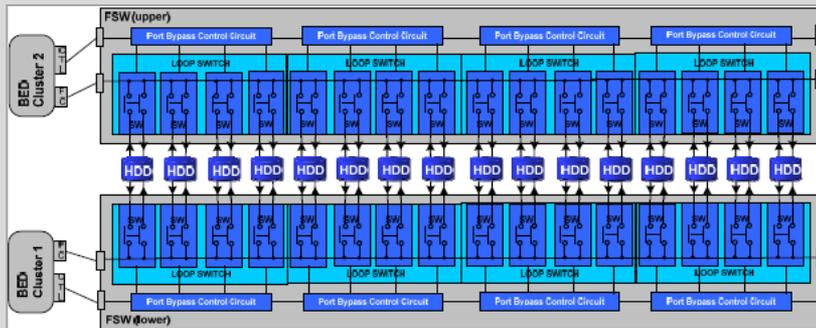

# Drive Types and Capacities

- Current Drive Technology:
  - 2.5" 10K 300GB, 600GB, and 900GB SAS
  - 2.5" 15K 146GB, and 300GB SAS
  - 2.5" Flash MLC 200GB and 400GB, SAS
  - 3.5" Flash MLC 400GB SAS
  - 3.5" 2TB and 3TB Nearline SAS / 7200 RPM
  - Hitachi Accelerated Flash storage 1.6TB
  
- New Drive Technology:
  - Hitachi Accelerated Flash storage (HAFs) 3.2TB
    - More about this later!
  - 2.5" 1.2TB 10K SAS
  - 3.5" 4TB Nearline SAS / 7200 RPM
  - 3.5" SATA Drives are EOL.

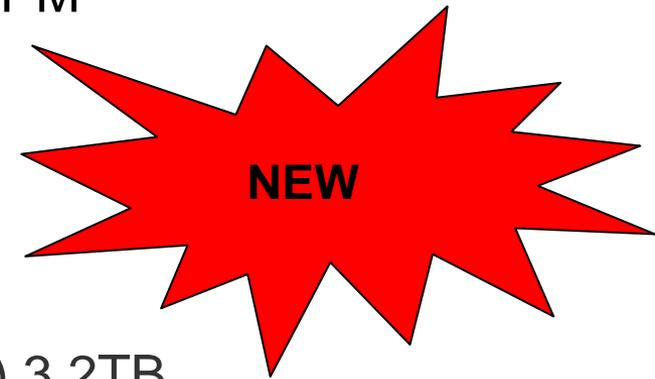

Virtual Storage Platform – Quick Technology Update



▪ Storage Virtualization in the Mainframe Environment

Dynamic Provisioning – Mainframe Environment

Dynamic Tiering – Mainframe Environment

Virtual Storage Platform (VSP) – Other NEW Features

Summary

# Storage Virtualization for Mainframe

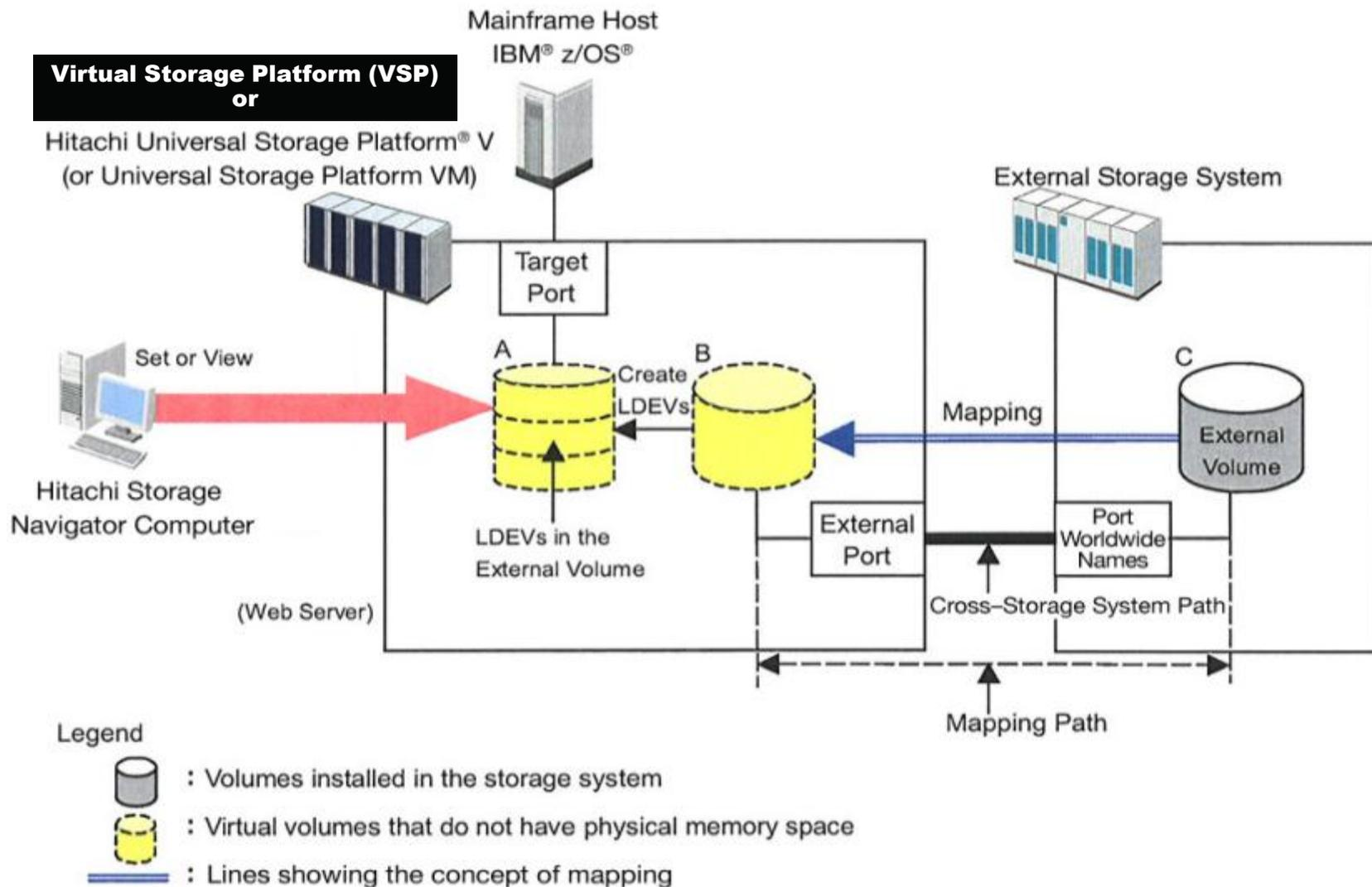

# Storage Virtualization for Mainframe

- Constantly adding new devices to the Virtualization Support Matrix.
- EMC VMAX and VNX
- IBM DS8000 Series – all models
- HP all models
  
- Industry Standard Virtualization Profile
  - No testing required
  - Plug and Play concept
    - Quick test for adherence to SCSI standards



Virtual Storage Platform – Quick Technology Update

- Storage Virtualization in the Mainframe Environment



- Dynamic Provisioning – Mainframe Environment

Dynamic Tiering – Mainframe Environment

Virtual Storage Platform (VSP) – Other NEW Features

Summary

# Hitachi Dynamic Provisioning (HDP) for Mainframe



- Provides fully compatible support for IBM features:
  - EAV
  - DVE
  - FlashCopy SE
  
- Dynamic Provisioning
  - Up to 128 unique pools (OPEN and Mainframe)
  - Space Savings or “Thin Provisioning” characteristics
  - Ultra Wide-Striping
    - Physical pools comprised of multiple array groups
    - 38MB pages striped across all storage in a pool
    - Improved performance – especially for sequential workloads

# Hitachi Dynamic Provisioning (HDP) for the Mainframe

- So, just what is a page?
  - For the VSP, there are two page sizes
    - OPEN – 42MB
    - Mainframe – 38MB
  - They are different to fit the best use of storage space for the underlying OS structures they support
  - For Mainframe, 38MB fits the 3390 architecture with minimal wasted space
- Each storage supplier has a different implementation
  - Some are in MB
  - Some are sub-LUN
  - Some are partial volumes
  - Some are Chunks / Chunklets
- Each is designed to best fit their architecture

# HDP Mainframe — Basic Concepts

## • Key Functionalities

- Thin Provisioning
  - Pool Rebalance
  - Pool Volume Reduction
  - Space Reclaim
- Support Mainframe Features
  - PAV, HyperPAV
  - z/HPF
- Support Replication Products
  - TrueCopy and HUR
  - ShadowImage and FlashCopy V2
- Support New Features
  - EAV and DVE
  - FlashCopy SE
  - Hitachi Dynamic Tiering

Complete your sessions evaluation online at [SHARE.org/BostonEval](http://SHARE.org/BostonEval)

## ■ With HDP for Mainframe

- Optimize storage performance by spreading the I/O across all available physical disk drives

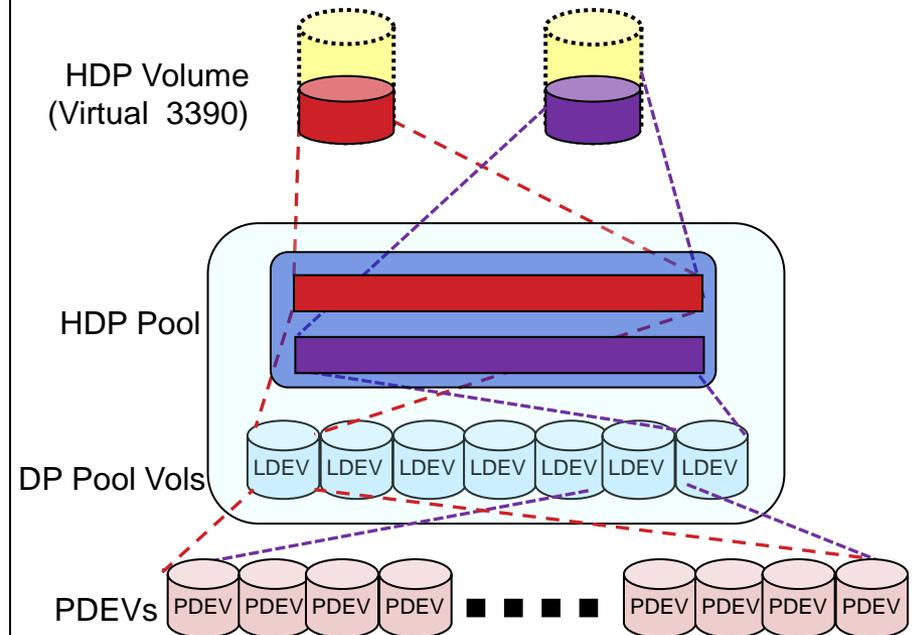

- Spreading data across more physical volumes reduces the I/Os per volume and improves performance



- Virtual Storage Platform – Quick Technology Update
- Storage Virtualization in the Mainframe Environment
- Dynamic Provisioning – Mainframe Environment
- Dynamic Tiering – Mainframe Environment



Virtual Storage Platform (VSP) – Other NEW Features

Summary

# Hitachi Dynamic Tiering for Mainframe



- **Dynamic Tiering**
  - **Open Systems available since September 2010**
  - **Mainframe available since January, 2012**
  - **Automated performance management**
  - **Cost effective use of storage tiers**
  - **Internal and external (virtualized) storage**
  - **Managed in pages (42MB for OPEN, 38MB for Mainframe)**
  
- **Cost savings through:**
  - **Improved storage utilization**
  - **Reduced storage requirements for Tier 1**
  - **Less time spent on performance management**
  - **Re-deploy personnel**
  - **Integration with SMS**

# Virtual Storage Platform: Page Level Tiering

- Different tiers of storage are in one pool of pages – up to 128 pools
- Automatically detects and assigns Tiers based on media type
- Dynamically:
  - add or remove Tiers
  - expand or shrink Tiers
  - expand 3390A volumes
  - move 3390A volumes between pools
- Dynamic Tiering Policies at volume level:
  - Default - All
  - Level 1 - Tier 1 only
  - Level 2 - Tier 1 and Tier 2 only
  - Level 3 - Tier 2 only
  - Level 4 - Tier 2 and Tier 3 only
  - Level 5 - Tier 3 only

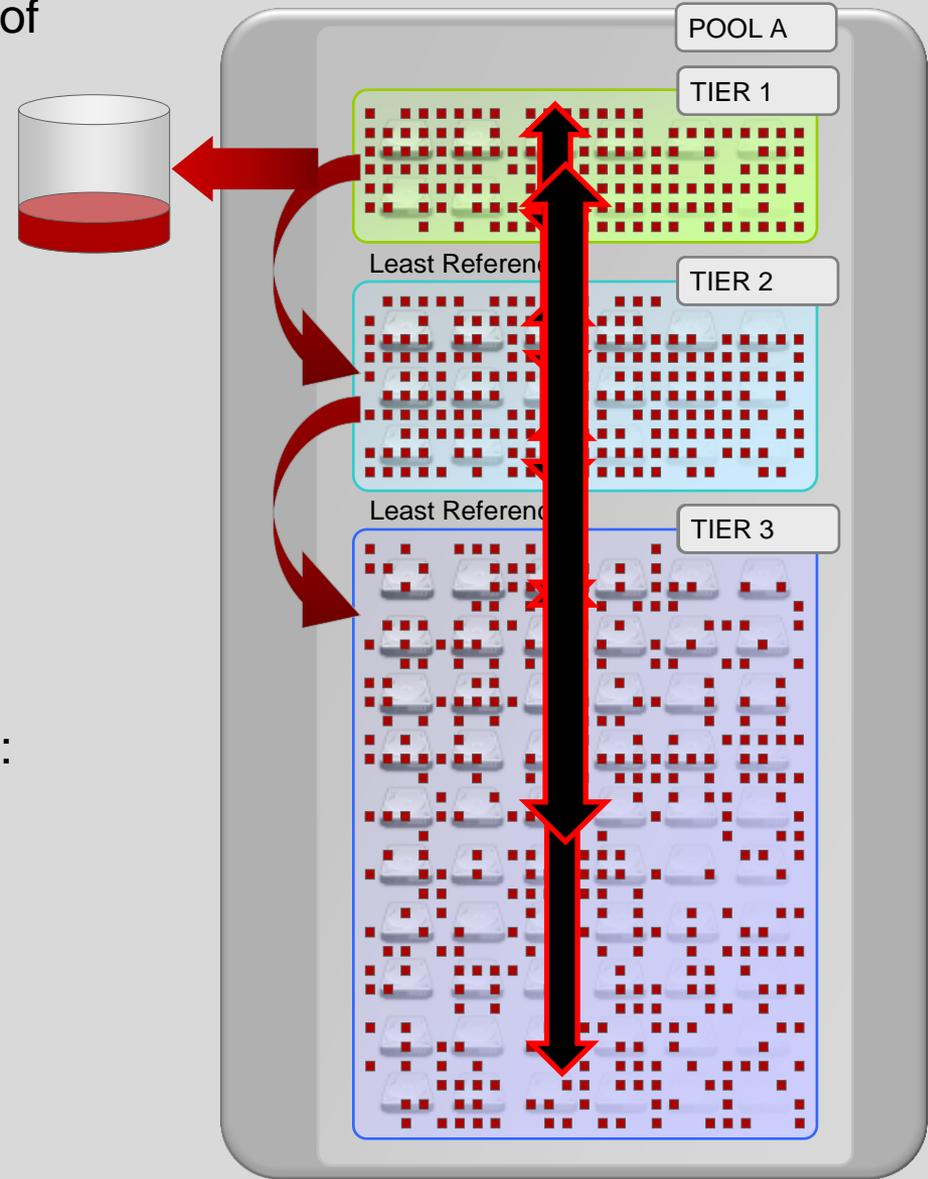

# Virtual Storage Platform - Page Level Tiering



## ■ Cycles

- Customer defines strategy, it is executed automatically
- 24 hour
  - defined part of 24 hour
  - ½, 1, 2, 4 or 8 hourly
  - All aligned to midnight
- Weekly or longer

## ■ Use Hitachi Tiered Storage Manager (HTsM) for Mainframe

- Set tiering policy schedules to match business cycles and requirements
- Report on data mobility (promotions and demotions)
- Dynamically change or adjust cycle, policies, tiers etc...

Media tier groupings supported by Hitachi VSP	Order of tiers
2.5" SSD (200GB) SLC or eMLC 2.5" SSD (400GB) SLC or eMLC Hitachi Flash Trays	1
2.5" SAS15Krpm (146GB) 2.5" SAS15Krpm (300GB)	2
2.5" SAS10Krpm (300GB) 2.5" SAS10Krpm (600GB) 2.5" SAS10Krpm (900GB)	3
3.5" SAS 7.2Krpm (2TB, 3TB)	4
3.5" SATA (2TB)	5
External	Lowest
External Multi Tier	Any Tier



# Hitachi Dynamic Tiering with SMS Storage Groups and ACS Routines

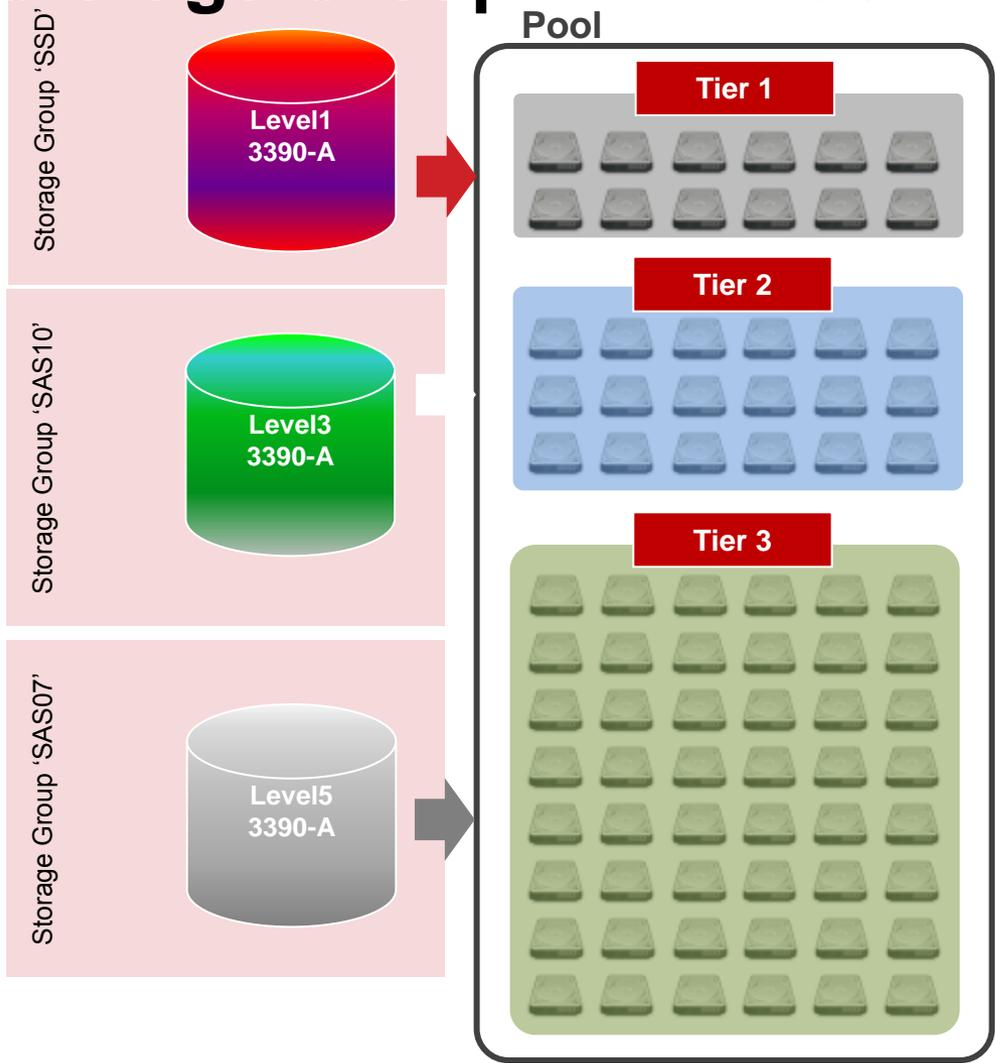

- Now the default Storage Group dynamically adjusts
- You can still have the 'old style' Storage Groups but now HSM isn't needed to transition between tiers or solve performance problems

# Hitachi Tiered Storage Manager for Mainframe – z/os HDT management

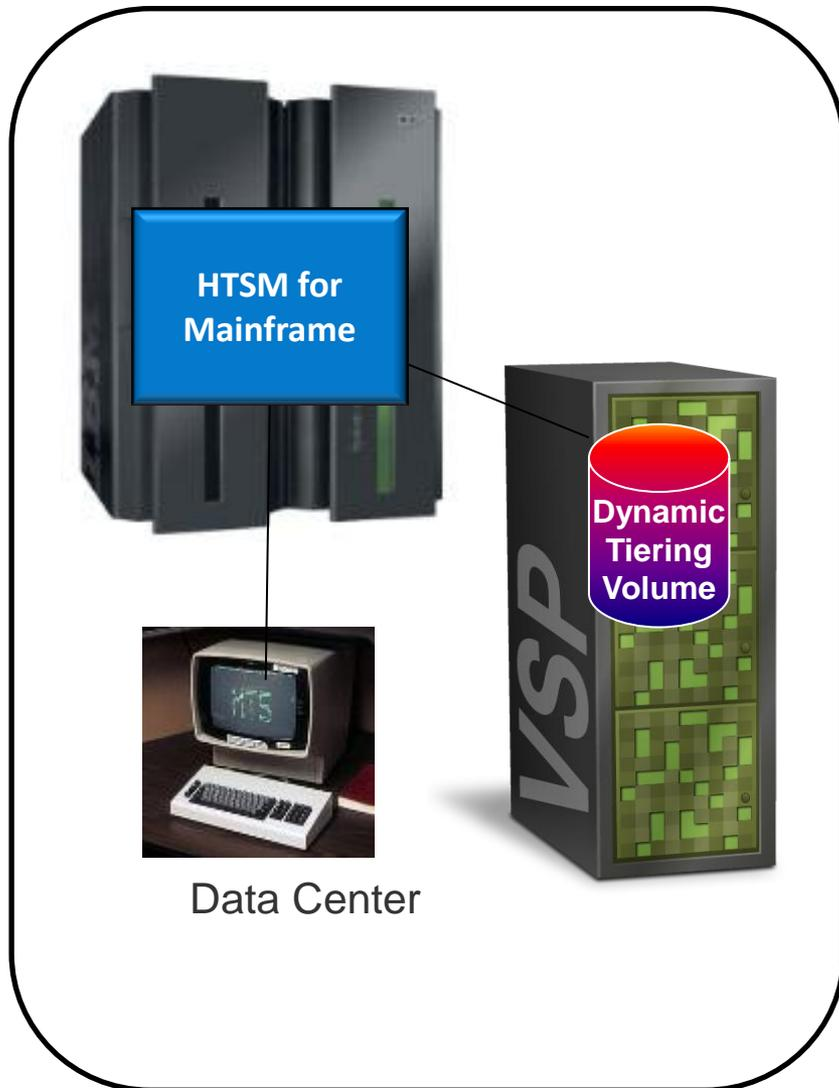

## Host-based software that provides:

- Centralized and unified mainframe management of Hitachi Dynamic Tiering
  - Automation
  - Integration with DFSMS and storage groups
- Online storage service level controls
  - Increase application performance
  - Improves problem avoidance
- Single, consistent interface
  - Command based, script driven
- Auto-discovery eliminates errors
  - Accelerates deployment
- Enables reporting and automatic notifications



- Virtual Storage Platform – Quick Technology Update
- Storage Virtualization in the Mainframe Environment
- Dynamic Provisioning – Mainframe Environment
- Dynamic Tiering – Mainframe Environment
- Virtual Storage Platform (VSP) – Other NEW Features
- Summary



# VSP – Other NEW Features



- Flash Acceleration Microcode
  - Improve throughput and performance
  - Microcode only change
  - Approximate 40% performance boost of VSD's.
  
- Hitachi Accelerated Flash storage (HAFs)
  - 3.2TB capacity SSD
  - Hitachi ASIC controller on each SSD drive.



# VSP Microcode Enhancement - Flash Acceleration



## VSD PERFORMANCE OPTIMIZATION

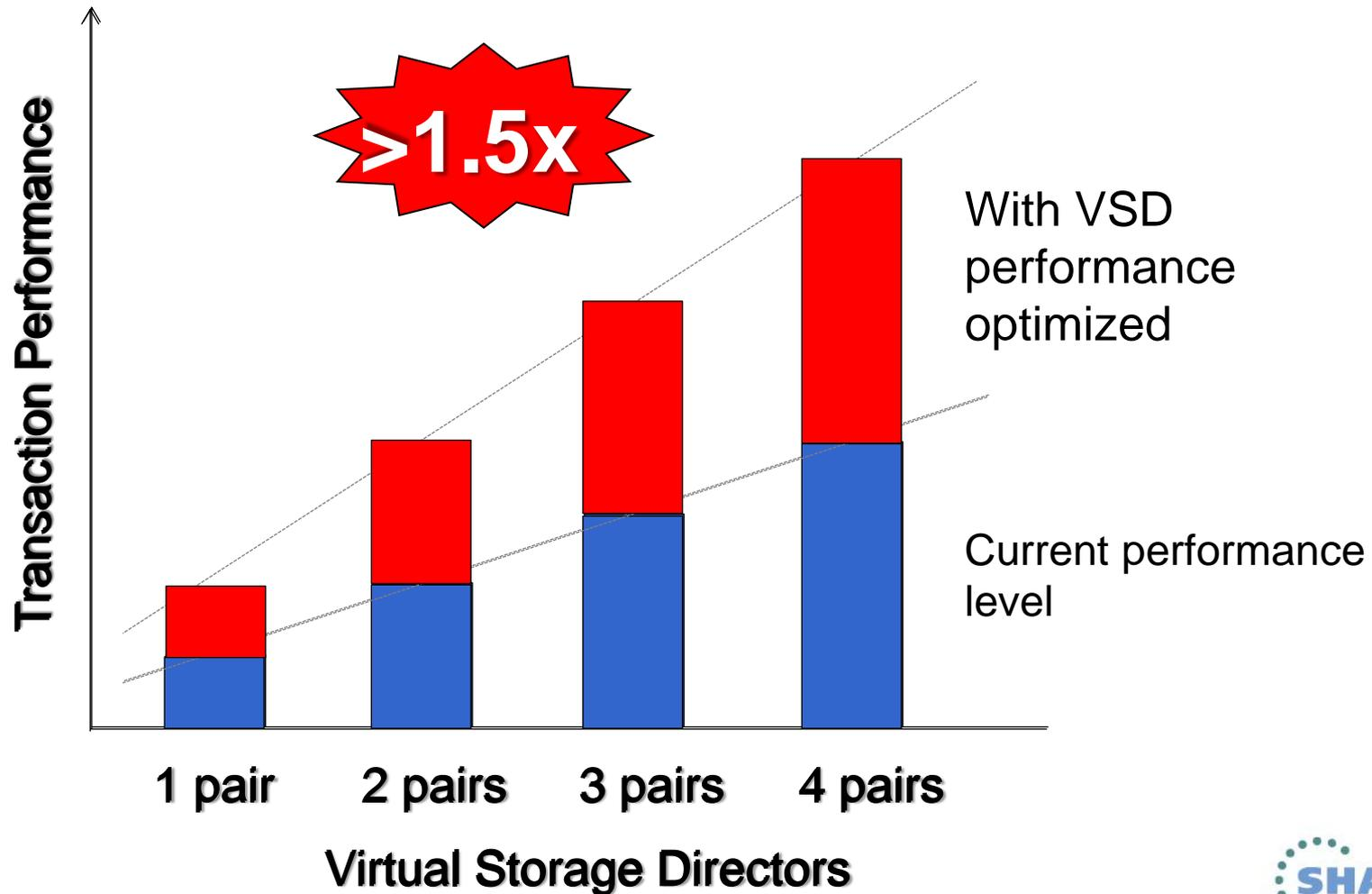

**Mainframe Flash Acceleration Performance**  
**PAIO - E1**  
**4KiB Chain(1)**  
**90% Cache Hit Ratio**  
**Response Time vs. IO Per Second**

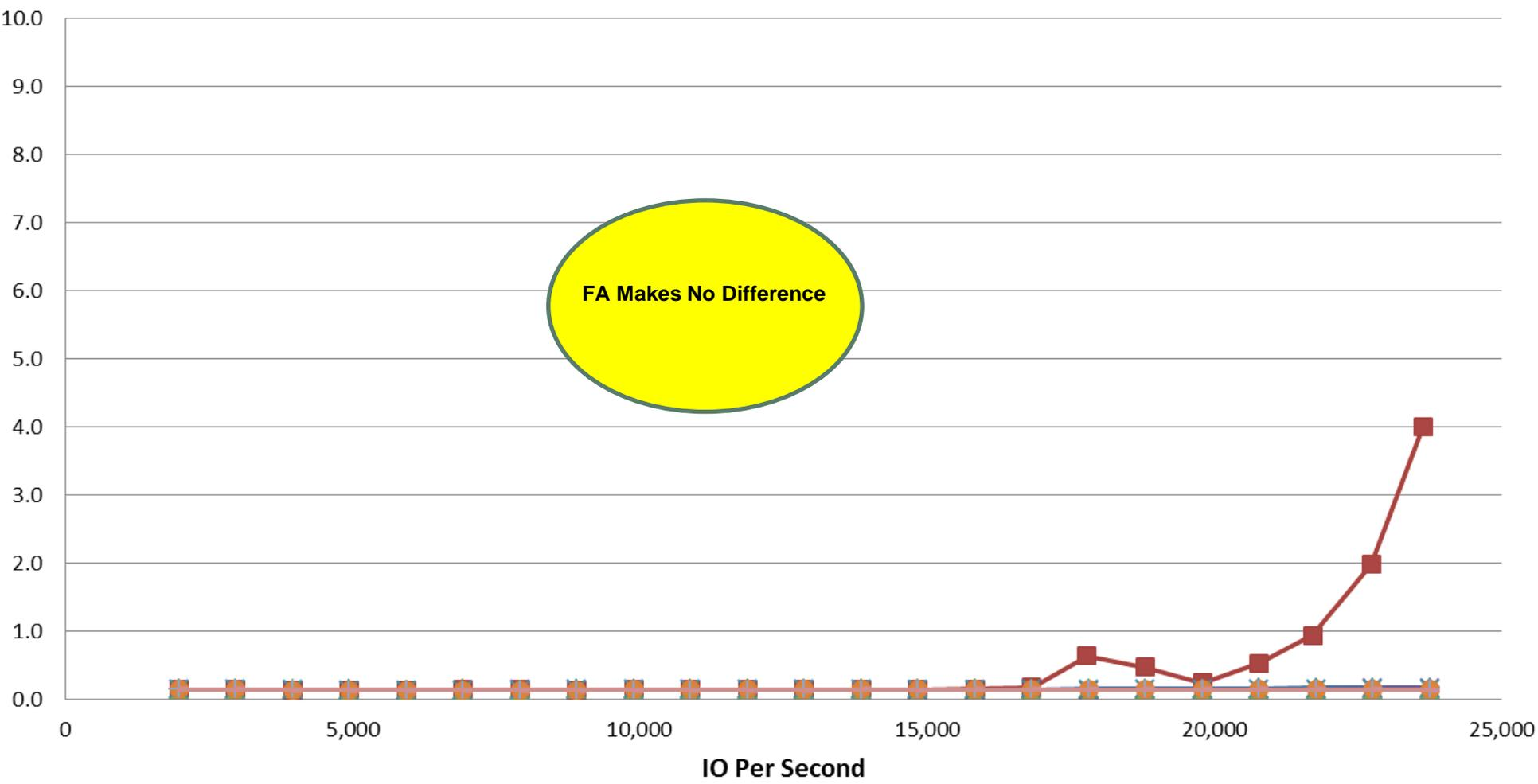

FAOFF\_1MP FAON\_1MP FAOFF\_2MP FAON\_2MP FAOFF\_3MP FAON\_3MP FAOFF\_4MP FAON\_4MP

# Mainframe Flash Acceleration Performance

## PAIO - H4

### 4KiB Zero Locality Read Chain(1)

### Response Time vs. IO Per Second

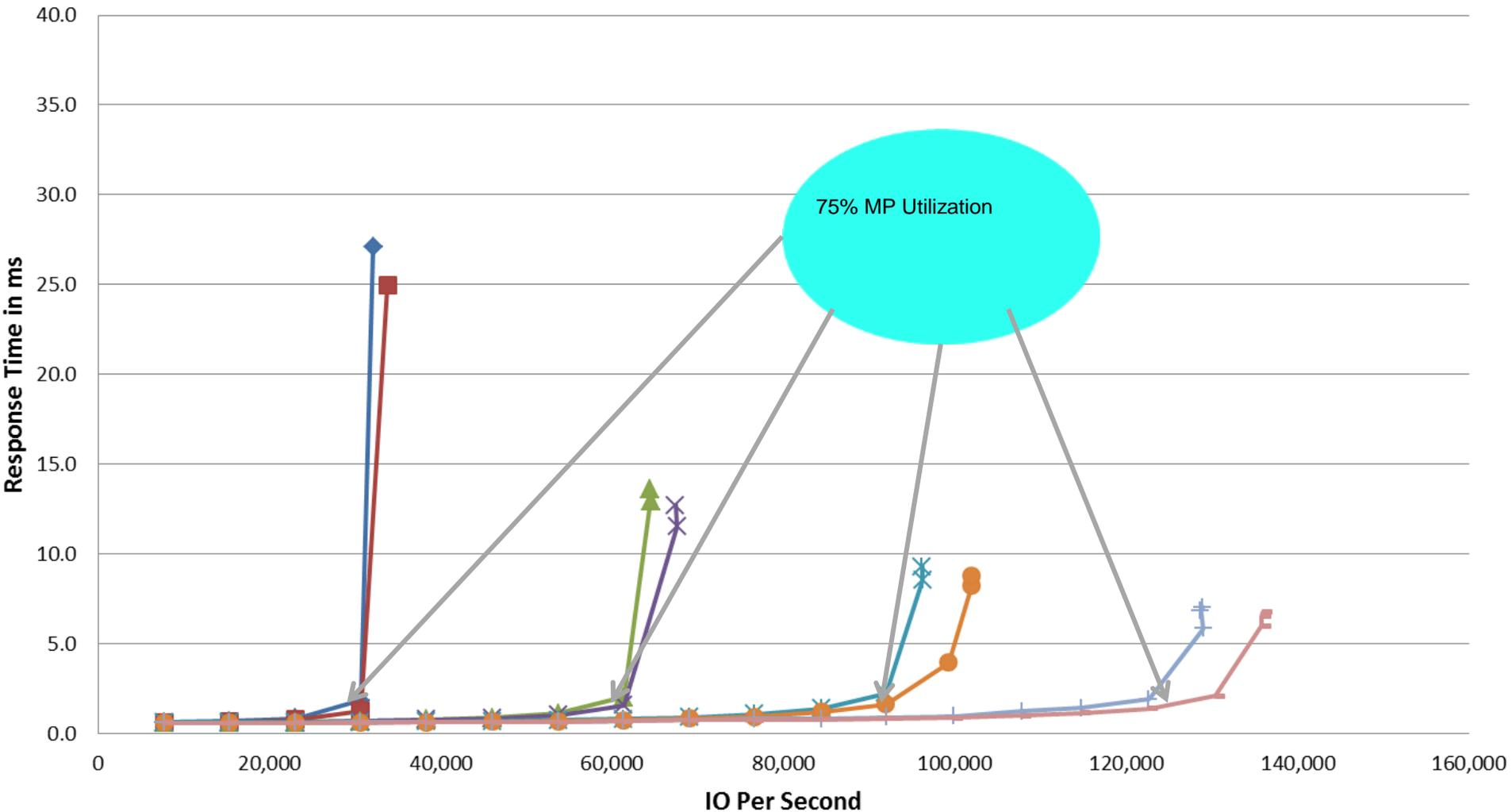

◆ FAOFF\_1MP ■ FAON\_1MP ▲ FAOFF\_2MP ✕ FAON\_2MP \* FAOFF\_3MP ● FAON\_3MP + FAOFF\_4MP — FAON\_4MP

# Hitachi Accelerated Flash storage (HAFs)

- The Flash Memory Drive (FMD) is Hitachi built specifically for Hitachi arrays.
- Each FMD is as follows:
  - Raw capacity option of 1.6TB (current), 3.2TB (Released this week)
  - eMLC based
  - Each FMD uses an Hitachi designed and built System-On-Chip (SOC) ASIC
    - Multi-Core ASIC performs flash memory management, data transfer, RAS etc.
    - High bandwidth PCIe Gen2 data paths to eMLC memory
    - Much improved performance over industry SSD

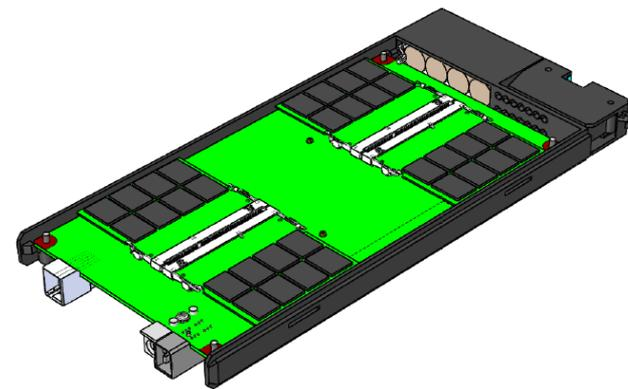
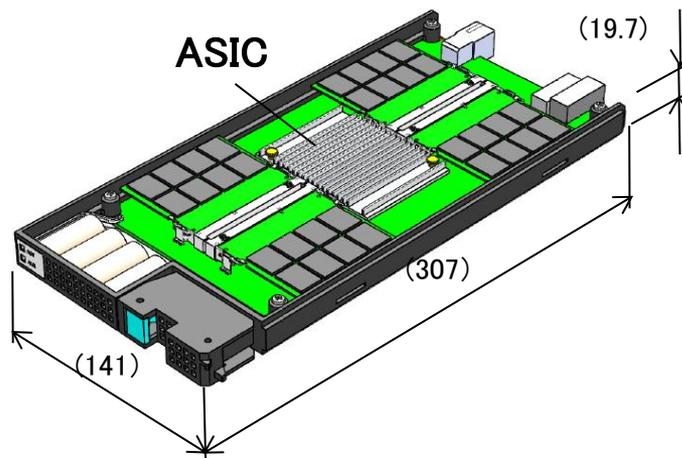

# Hitachi Accelerated Flash Controller Architecture

- Functional view

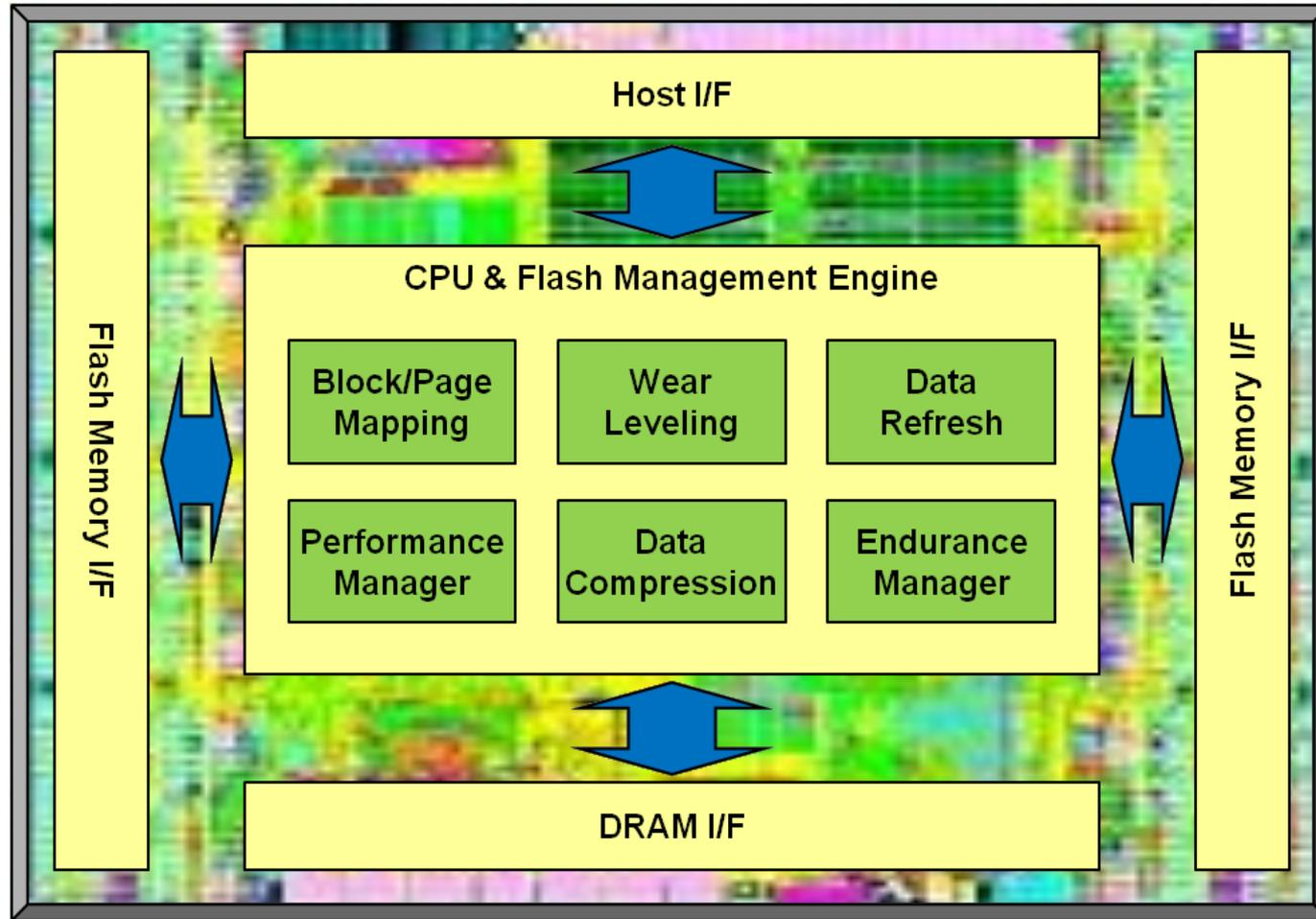

# Hitachi Accelerated Flash storage (HAFs)

- VSP will offer granularity of 4 Flash Memory Drives (FMD) minimum, in 4 separate FMU (tray)
- VSP can support a total of 192 FMD's
  - 12 Flash FMD's per FMU
  - 4 FMU per Flash Box (FBX - similar to current Disk Chassis)
  - 4 FBX per VSP (2 per Control Chassis) (192 FMD's)
  - Total raw capacity: **307TB** (1.6TB FM), **614TB** (3.2TB)
- Target performance is >1 Million Random Read IOPS per FMU
- Available for all VSP's and non-disruptive install on live VSP's
- Latest Improvements in flash technology
  - Cost effectiveness per TB improved considerably
  - Expect market adoption to be very high

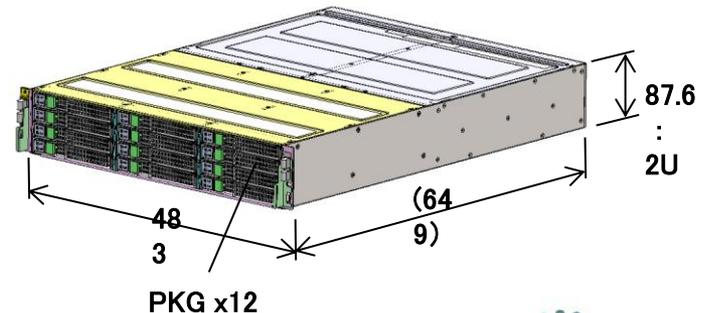

# New Hitachi Flash Technology

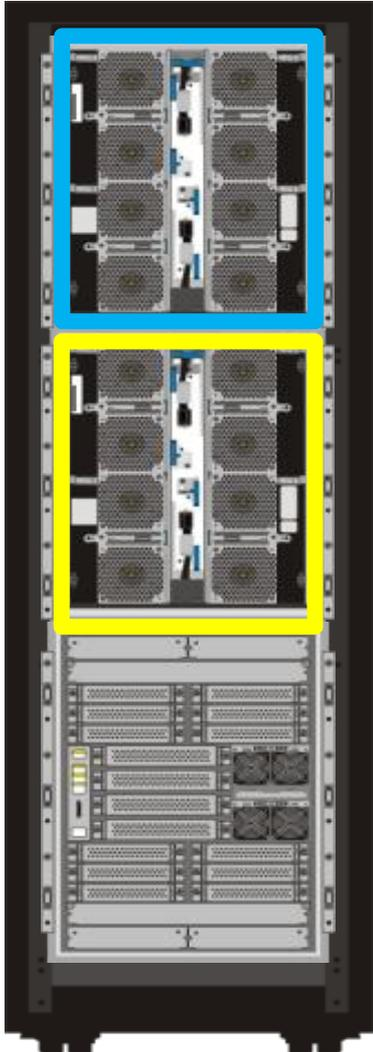

## SBX Drive Chassis

- 80/128 HDD/SSD's

## FBX Flash Tray Chassis

- 4 Trays
- 12 Flash Modules / Tray
- 48 Flash Modules / Chassis

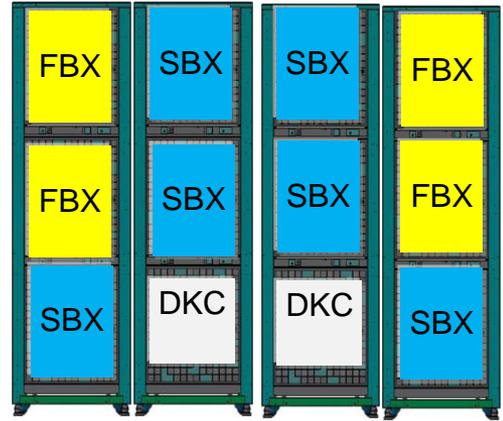
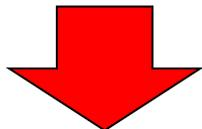
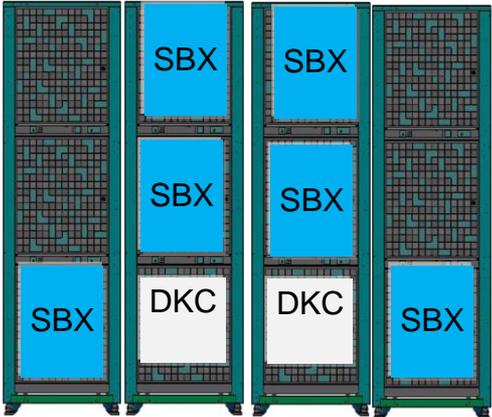

# HAFs Random Performance and Bit Cost Advantages Compared To MLC SSD

### 8K IOPS (64/36 R/W Ratio) Per Drive

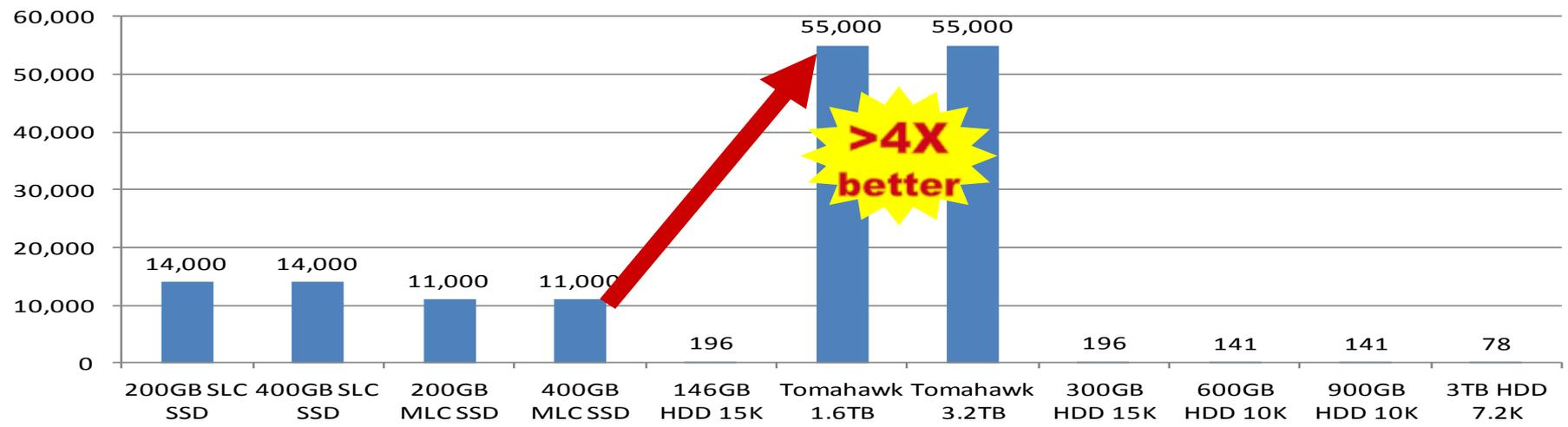

### NORMALIZED BIT PRICE COMPARED TO 146GB 15K RPM HDD AND MLC SSD

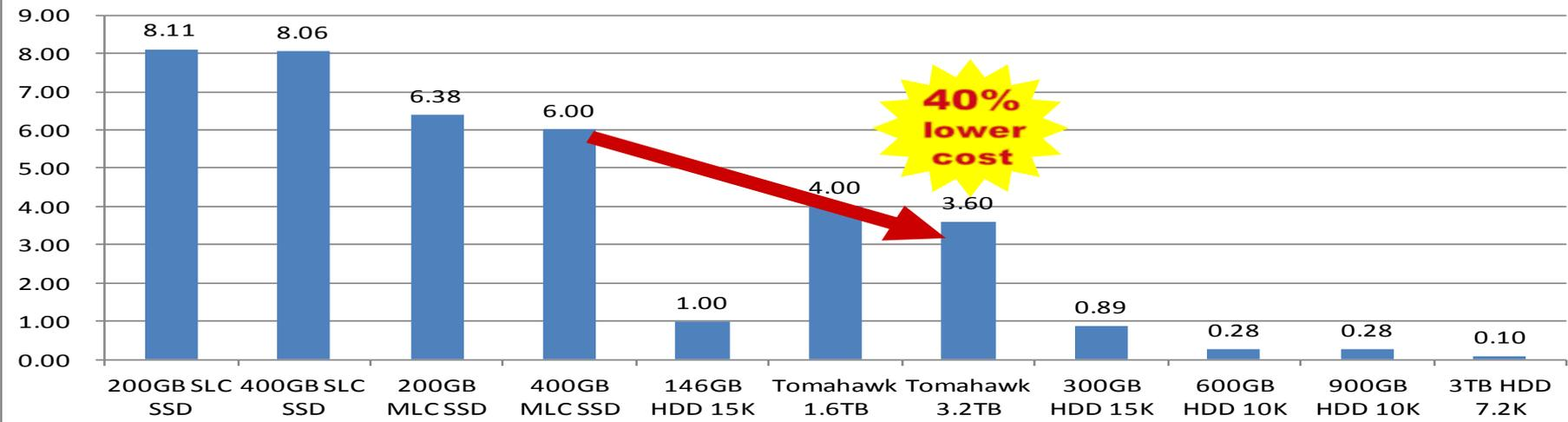

# HAFs Power Per TB and Random Performance Footprint Compared To MLC SSD



## Power per TB (incl. Drive and Chassis) (Watts)

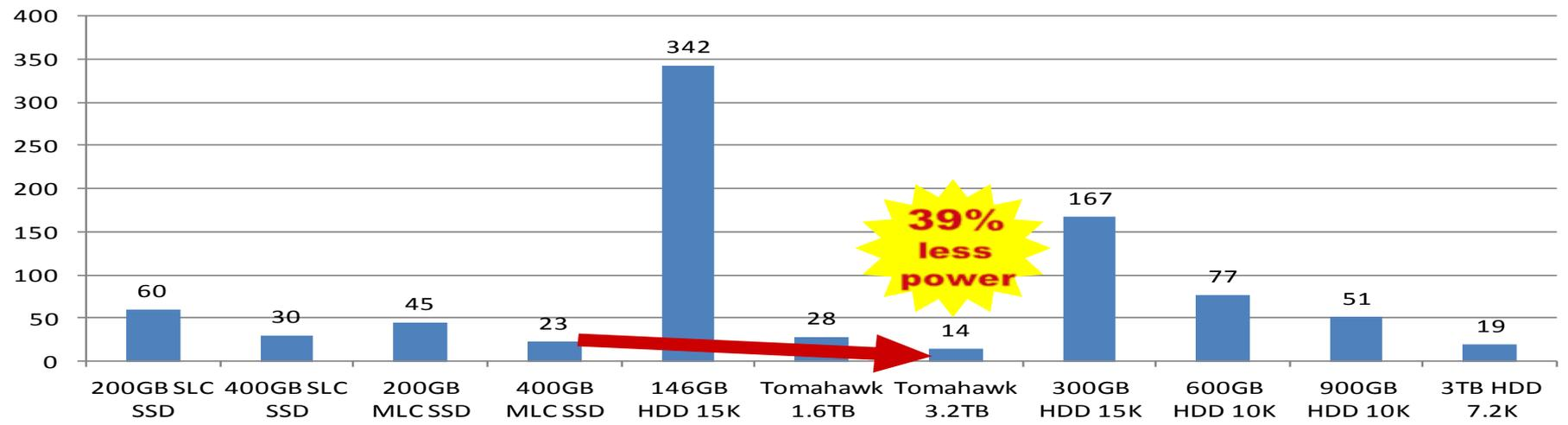

## 8K IOPS (64/36 R/W Ratio) Per 2U Rack

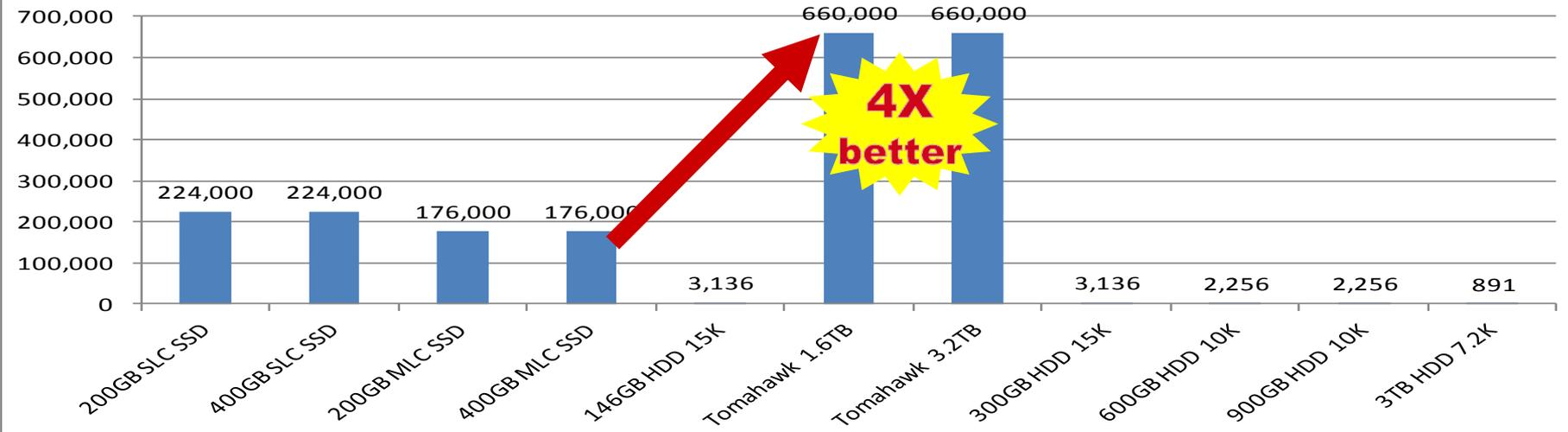

# VSP - SPC-1 BENCHMARK



- Hitachi's strategy is focused on scalability and price/performance

## SPC-1 Benchmark Comparison

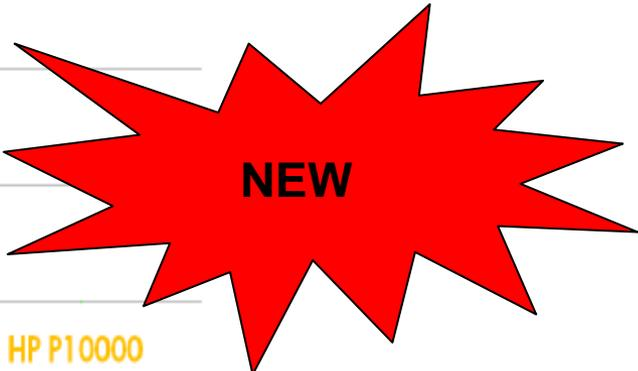
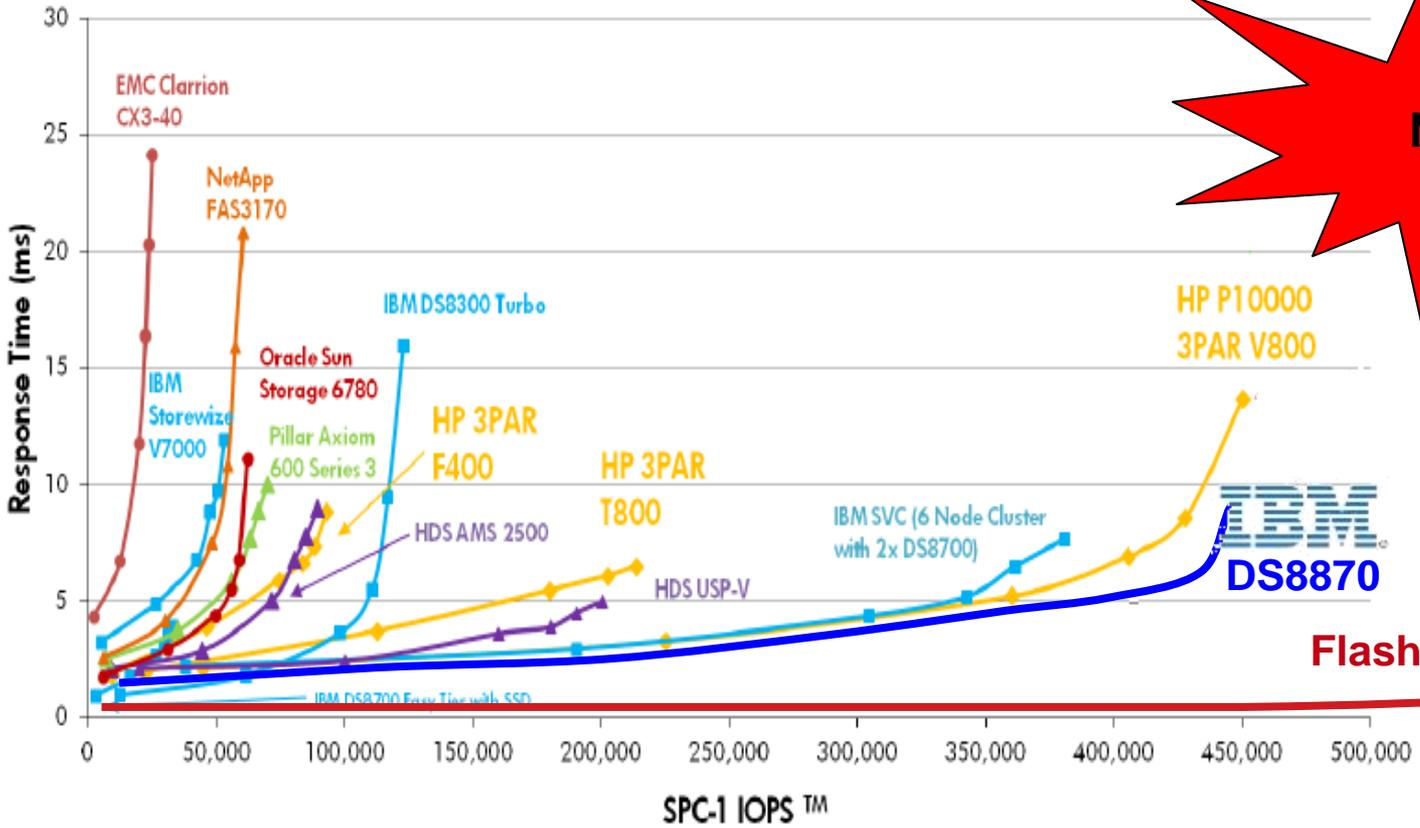

**HITACHI**  
Flash accelerated VSP





- Virtual Storage Platform – Quick Technology Update
- Storage Virtualization in the Mainframe Environment
- Dynamic Provisioning – Mainframe Environment
- Dynamic Tiering – Mainframe Environment
- Virtual Storage Platform (VSP) – Other NEW Features
- Summary



# Mainframe VSP Summary

- **Easy to implement**
- **Take advantage of storage tiers**
- **Take advantage of advanced features and functions of the VSP**
- **Extend the useful life of existing assets**
- **Provide Mainframe connectivity to lower cost Midrange storage platforms**
- **Single management point for all Mainframe storage**
- **Non-disruptively move data within a single VSP frame**
- **Non-disruptively move data across multi-vendor storage frames**
- **Improved storage utilization**
- **Improved Quality of Service (QoS)**



# ADDITIONAL HDS PRESENTATIONS



Session # 14332 – Wednesday, 3:00 PM, Room 209

- Solving Complex Mainframe Replication and Data Protection Problems with the Hitachi Virtual Storage Platform

Session # 13979 – Wednesday, 3:00 PM, Room 305

- Hitachi Dynamic Tiering – Managing Your Mainframe Storage Easily and Effectively

Lunch and Learn – Thursday, 12:15 PM, Room 310

- Storage Economics – Lunch Provided.

Session # 14069 – Thursday, 1:30 PM, Room 311

- Simplified Migrations Along with Improved Backup and Disaster Recovery



Thank you!