



# z/VM 6.3 Installation and Configuration Hands-on Lab

Sessions 13502, 13503, 13504



Richard Lewis – IBM Advanced Technical Skills (WSC) [rflewis@us.ibm.com](mailto:rflewis@us.ibm.com)

Bruce Hayden – IBM Advanced Technical Skills (WSC) [bjhayden@us.ibm.com](mailto:bjhayden@us.ibm.com)



# Objectives

- Provide a basic understanding of the z/VM concepts necessary to host Linux guests
  - z/VM virtualization concepts
  - z/VM installation and customization tasks
  - Linux guest creation and cloning tasks
- Provide hands on experience
  - Installing z/VM 6.3
  - Customizing an SSI cluster
  - Creating and cloning Linux images
  - Relocating Linux virtual machines

## How Does VM Work?

- The VM operating system uses the real resources assigned to it to create and control "Virtual Machines", control real devices, and simulate devices for the use of virtual machines.

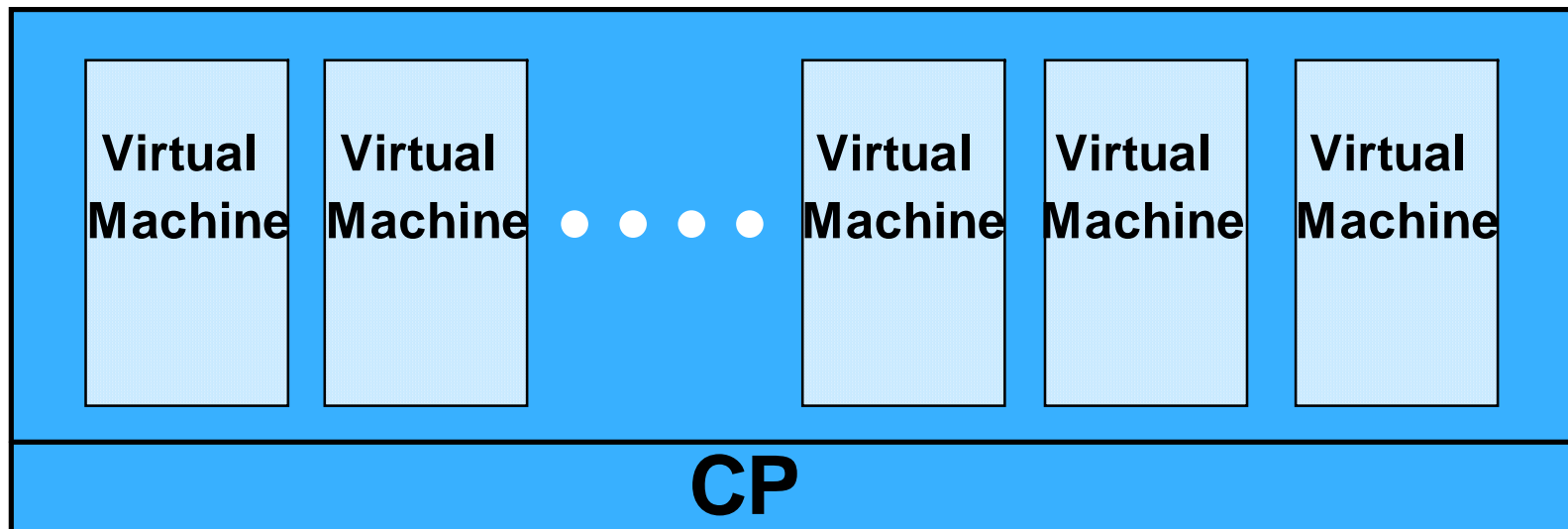

# The Virtual Machine

- A virtual machine
  - is a functional simulation of all of the elements of a real computer system.
  - has a name associated with it called the **Userid or Identity**
  - has its initial configuration defined in the **User Directory**
  - is created and its resources are allocated when the userid is **logged on**.
  - may be modified dynamically using CP commands.
  - is completely isolated from
    - other virtual machines
    - the Control Program



# Elements of a Real Computer System(of the 1960s)

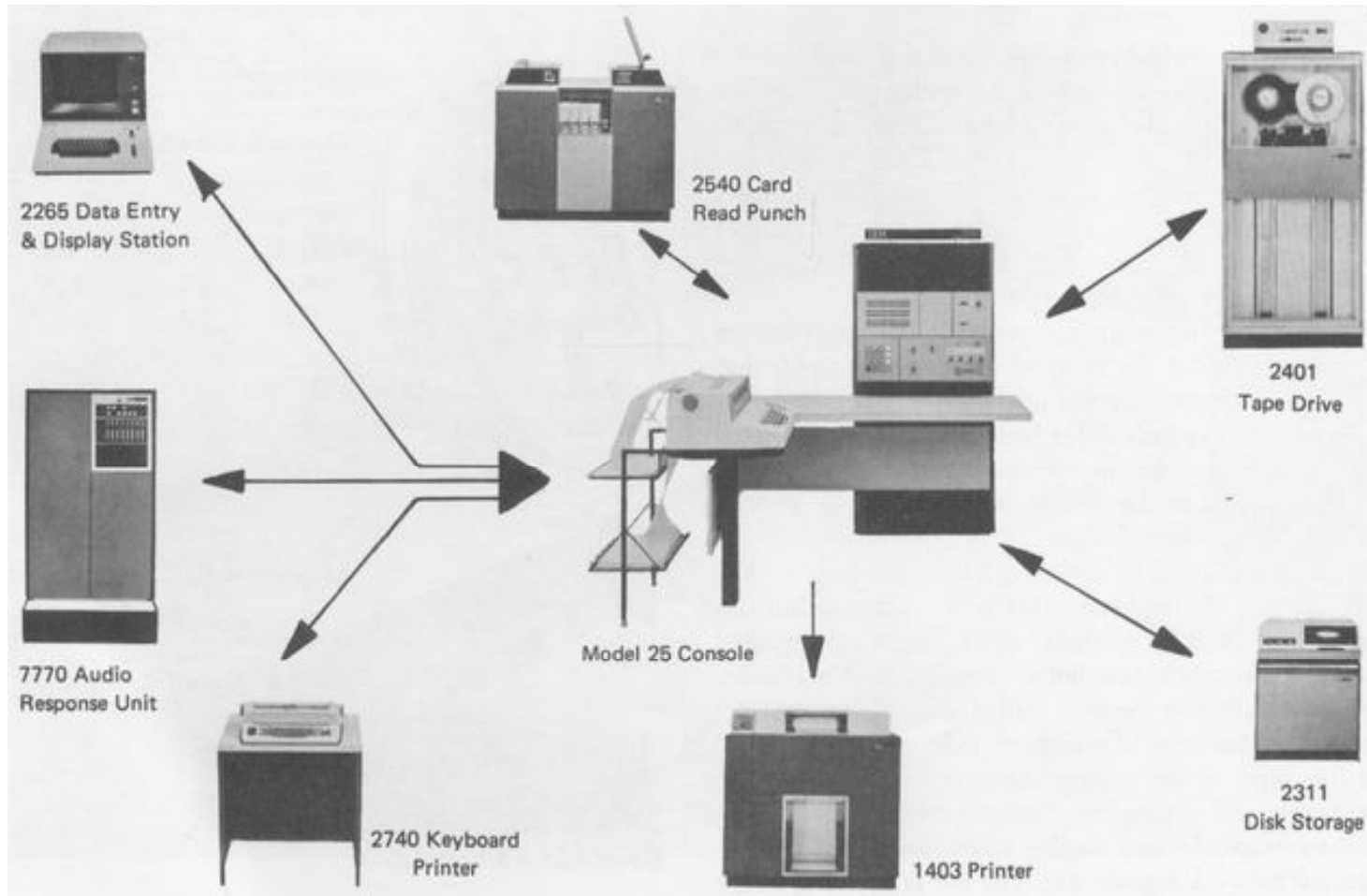

# Virtual Processors

- Each virtual machine may have from 1 to 64 virtual processors which possess all of the characteristics of the real processors on which z/VM is running.
- VM dispatches the virtual processors on the real processors, based on internal algorithms and the performance settings of the virtual machine.
  - Note: z/VM 6.3 now dispatches virtual processors with an awareness of the real hardware topology

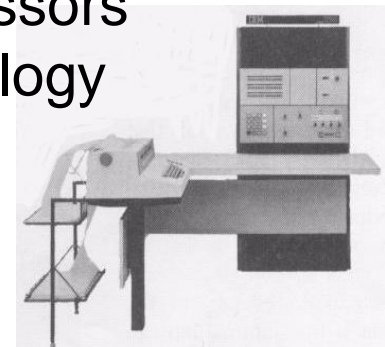

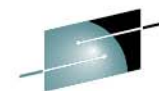

**SHARE**  
Technology • Connections • Results

# Virtual Storage

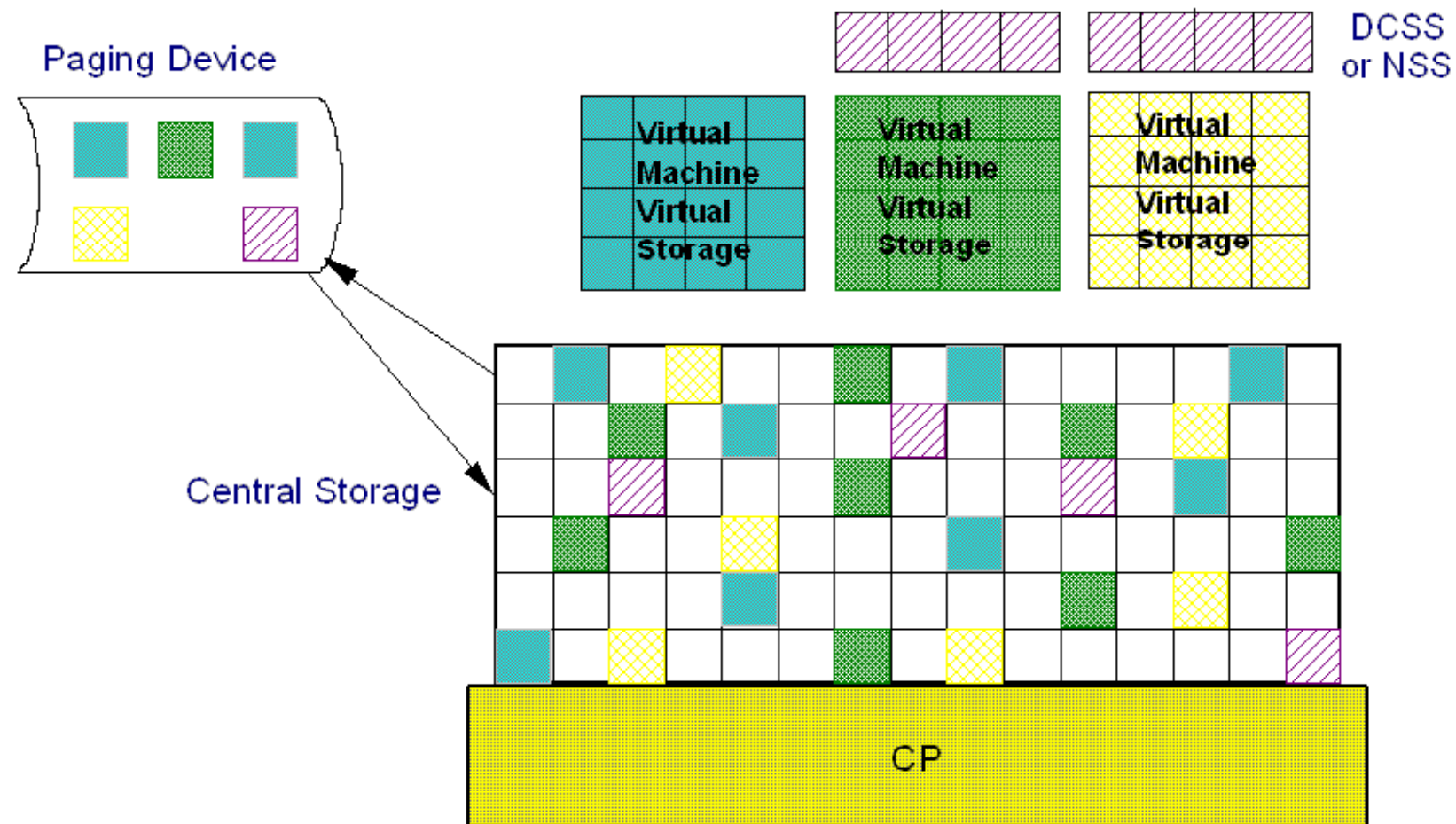



# Virtual I/O Devices

- There are several types of virtual devices:
  - Dedicated devices
    - Tape drives, disks, network adapters, etc.
  - Minidisks
    - Allows more granular allocation of disk space
    - Permanent and temporary
  - "Virtual only" devices
    - Virtual Disks in Storage
    - Card readers, printers and punches
    - Virtual channel-to-channel adapters
    - Virtual LAN adapters
    - Virtual Coupling Facilities
- Types of devices in use may effect eligibility for Live Guest Relocation

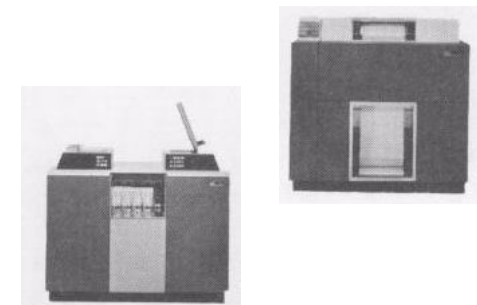
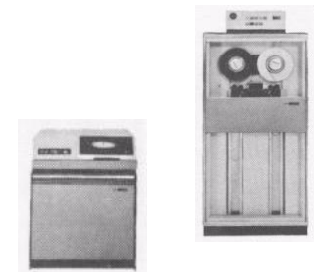



# Dedicated Devices

What CP 'sees':  
2 tape drives at  
real addresses  
600 and 601.  
They have been  
assigned to virtual  
machines VM1  
and VM2

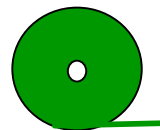

600

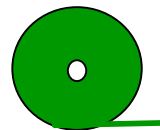

601

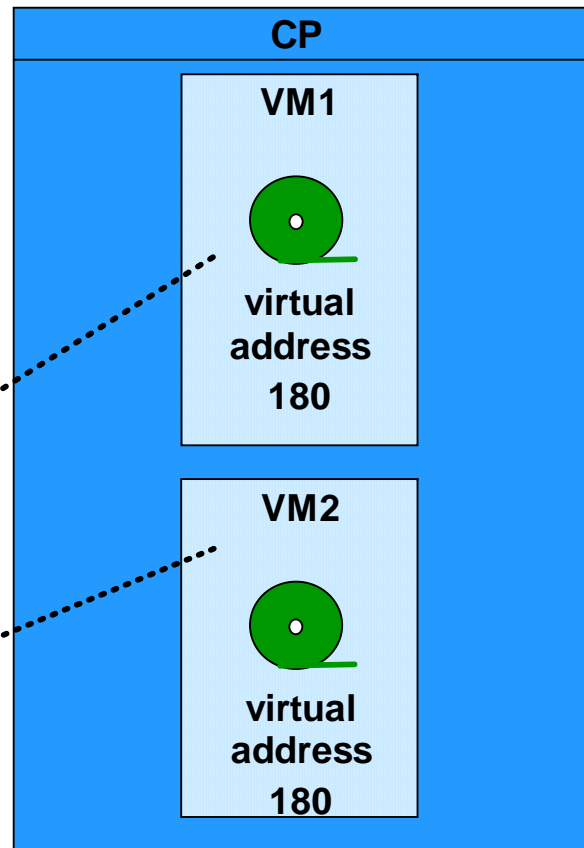

What the virtual  
machines "see":

VM1 - 1 tape drive  
at address 180

VM2 - 1 tape drive  
at address 180

# Minidisks

- A minidisk (mdisk) is a portion of a real DASD device which has been allocated for use by a virtual machine.
  - It can be as small as 1 cylinder or as large as the entire DASD device
  - It appears as a real dasd device to the virtual machine
  - with the same device characteristics as the real device on which it resides
  - The owner, location, and virtual address are defined in the User Directory

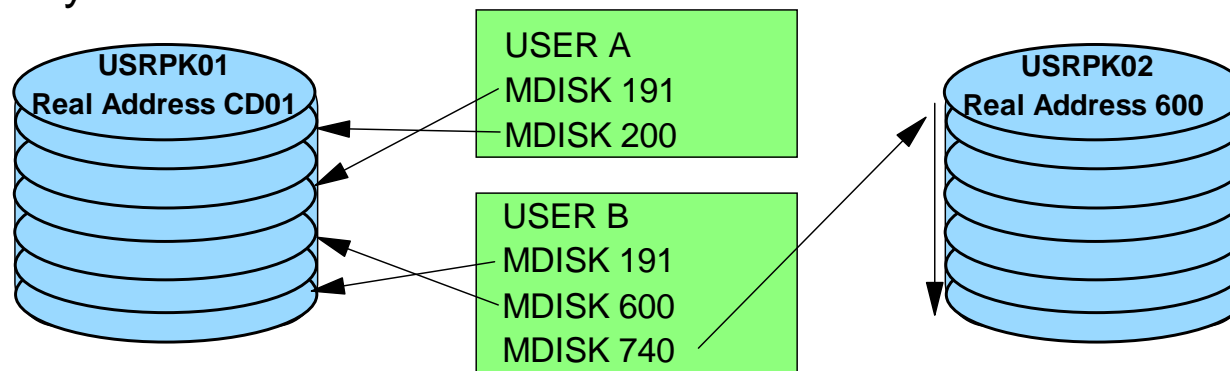

# Virtual LAN Adapters Virtual Switches (z/VM 4.4 +)

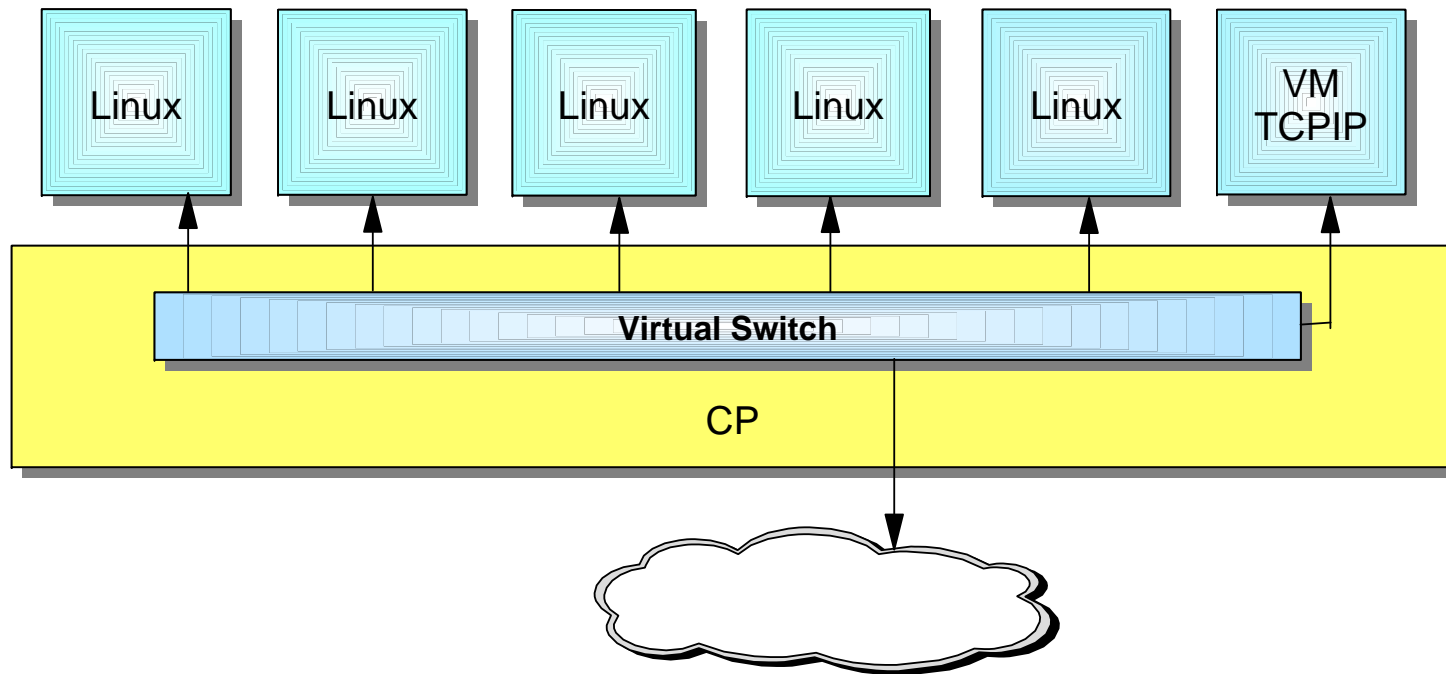

New Virtual Switches allow virtual QDIO connections to physical LAN segments without requiring a router

Allows virtual machines to be in the same subnet with the physical LAN segment

Potentially reduces overhead associated with QDIO Adapters

# Virtual Console

- **Simulates the operation of a real system console**

- Commands provide "virtual" hardware functions
  - IPL, Start/Stop, Display/Store, etc.
- Virtual device for use as operating system console
  - Emulates a 3215 or 3270 device
  - May be either
    - **Connected** - associated with the real device (3270) where the virtual machine was logged on
    - **Disconnected** - not associated with any real device
      - > Logged on and later disconnected or initialized in the disconnected state (AUTOLOG)
      - > Operations in the virtual machine continue
      - > Commands may still be issued to the virtual machine
      - > Console messages can be saved or passed to other virtual machines
      - > Most server virtual machines run disconnected
      - > Logon process reconnects a virtual machine to a display
      - > Console must be in this state for relocation

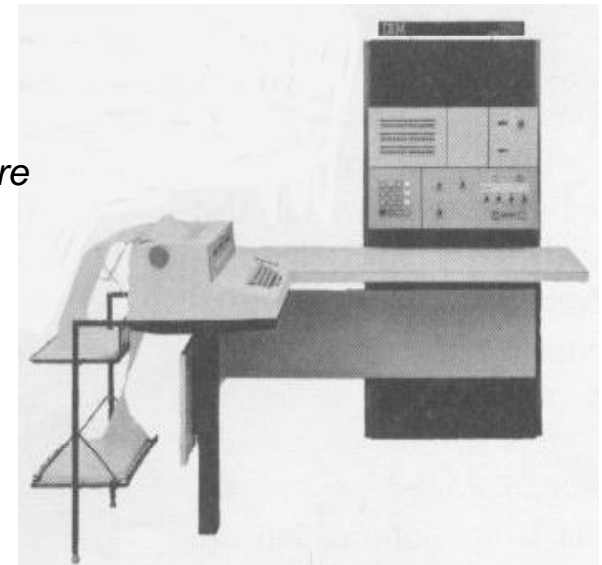

# Logging On a Virtual Machine

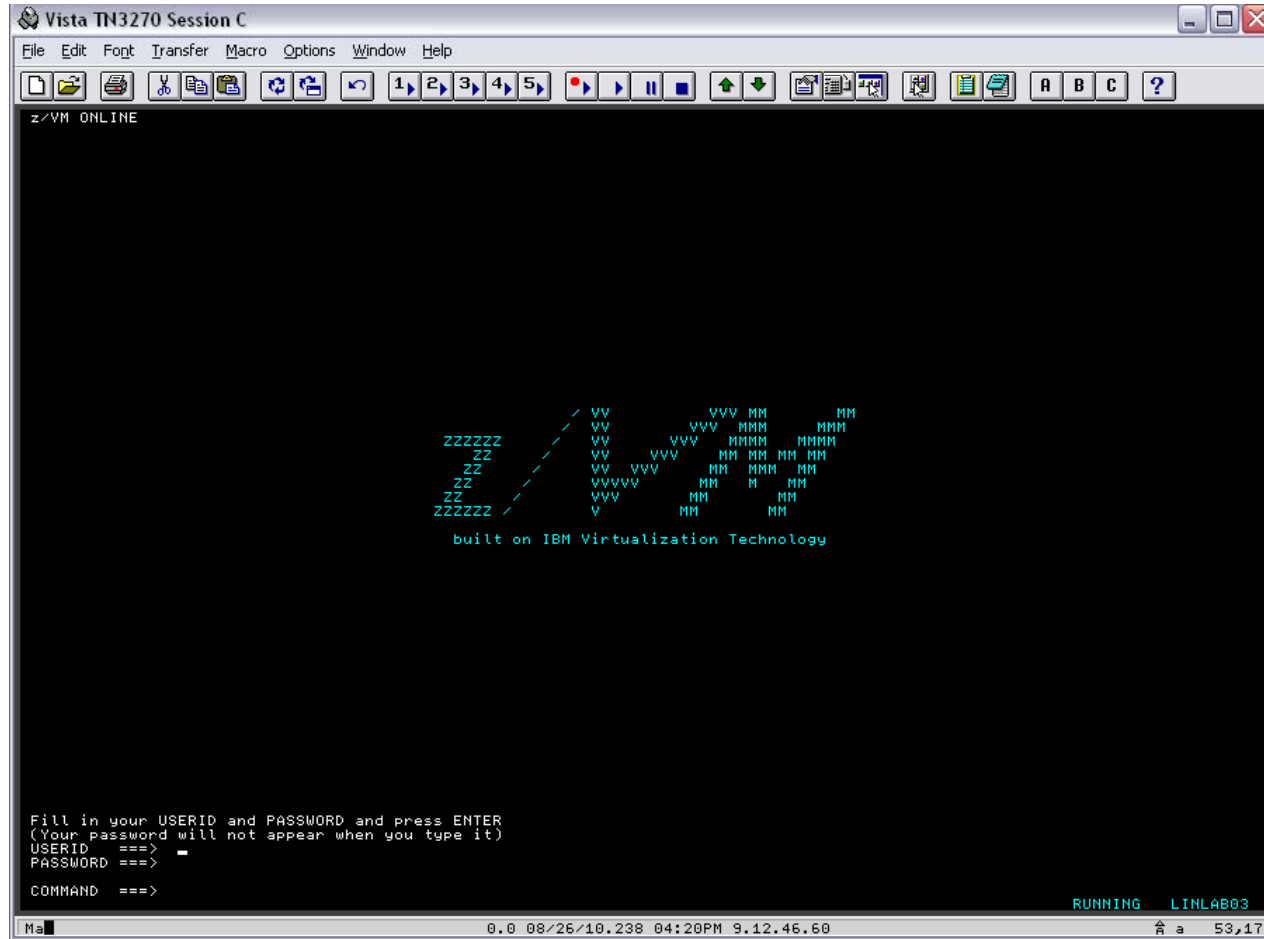

# LOGON PROCESS

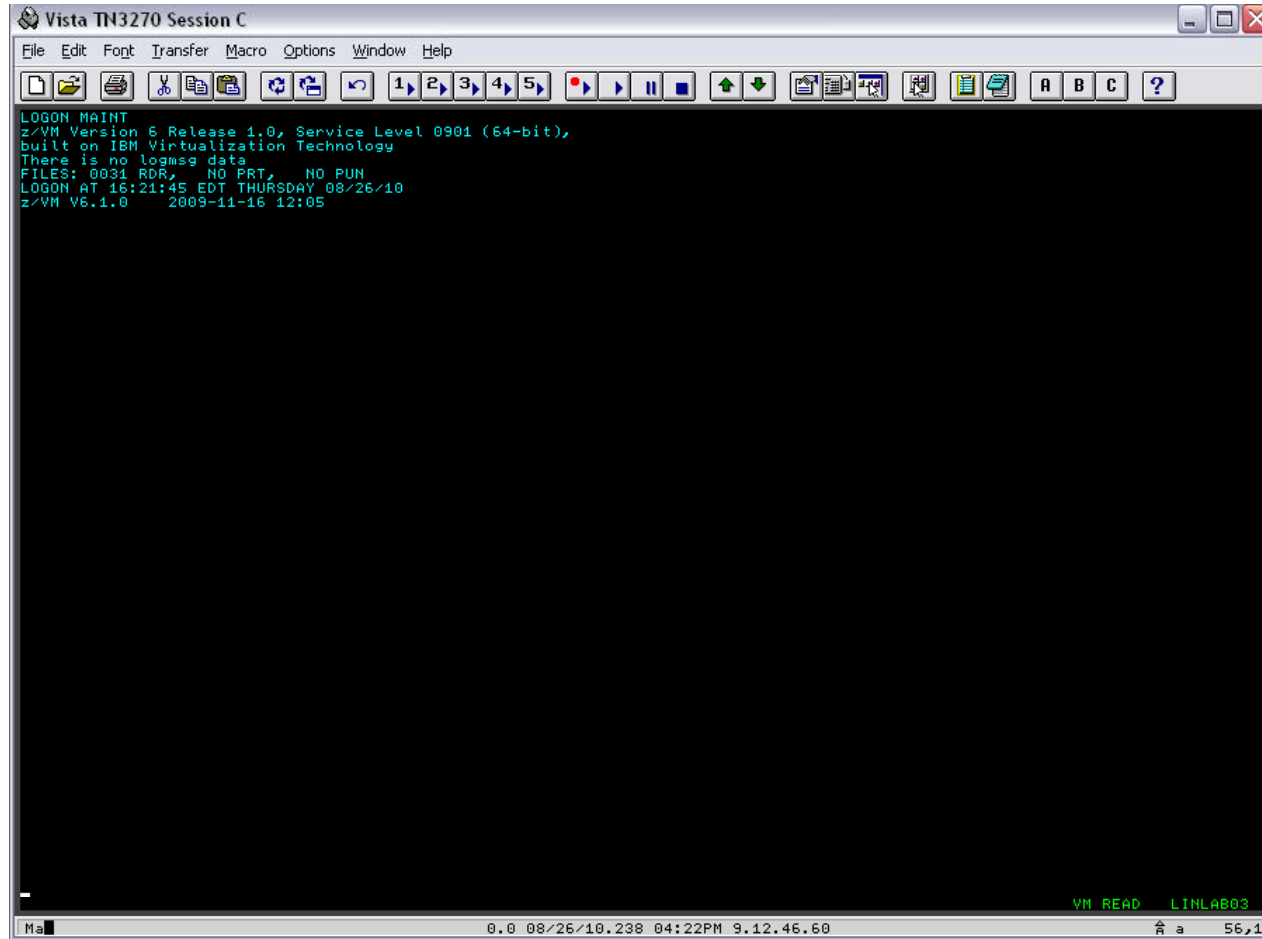

Vista TN3270 Session C

File Edit Font Transfer Macro Options Window Help

LOGON MAINT  
z/VM Version 6 Release 1.0, Service Level 0901 (64-bit),  
built on IBM Virtualization Technology  
There is no logmsg data  
FILES: 0031 RDR, NO PRT, NO PUN  
LOGON AT 16:21:45 EDT THURSDAY 08/26/10  
z/VM V6.1.0 2009-11-16 12:05

VM READ LINLAB03

Ma 0.0 08/26/10.238 04:22PM 9.12.46.60 ^ a 56,1

## CP Commands

- CP commands are used to alter or query the state of the virtual machine or the VM system and all associated real and virtual devices.
  - The CP commands a user may issue are restricted by the user's assigned Privilege class.
- CP commands are not case sensitive.
- Commands can be passed directly to CP, bypassing the virtual machine operating system
  - Use the PA1 key to enter the CP environment and issue commands.
  - Precede the command with #CP
    - We will change this to %CP in the lab



# Operating Systems

- Once a virtual machine has been created by VM, it needs an operating system or standalone program to perform work. Operating systems are loaded into the virtual machine through the IPL (Initial Program Load) process, just like a real machine.
- Some of the operating systems that can run under VM are:
  - CMS
  - Linux for IBM System z
  - OS/390, z/OS
  - VSE
  - TPF
  - VM

# CMS

- The CMS component of VM provides an interactive environment for users to:
  - Write, test, debug and run applications
  - Create and edit files
  - Process batch jobs
- CMS facilities include:
  - Shared File System
  - Pipelines
  - OpenExtensions
  - XEDIT
  - HELP Facility

# Single System Image Feature Clustered Hypervisor with Live Guest Relocation

- Provided as an optional priced feature.
- Connect up to four z/VM systems as members of a Single System Image (SSI) cluster
- Provides a set of shared resources for member systems and their hosted virtual machines
- Cluster members can be run on the same or different System z servers
- Simplifies systems management of a multi-z/VM environment
  - Single user directory
  - Cluster management from any member
    - Apply maintenance to all members in the cluster from one location
    - Issue commands from one member to operate on another
  - Built-in cross-member capabilities
  - Resource coordination and protection of network and disks

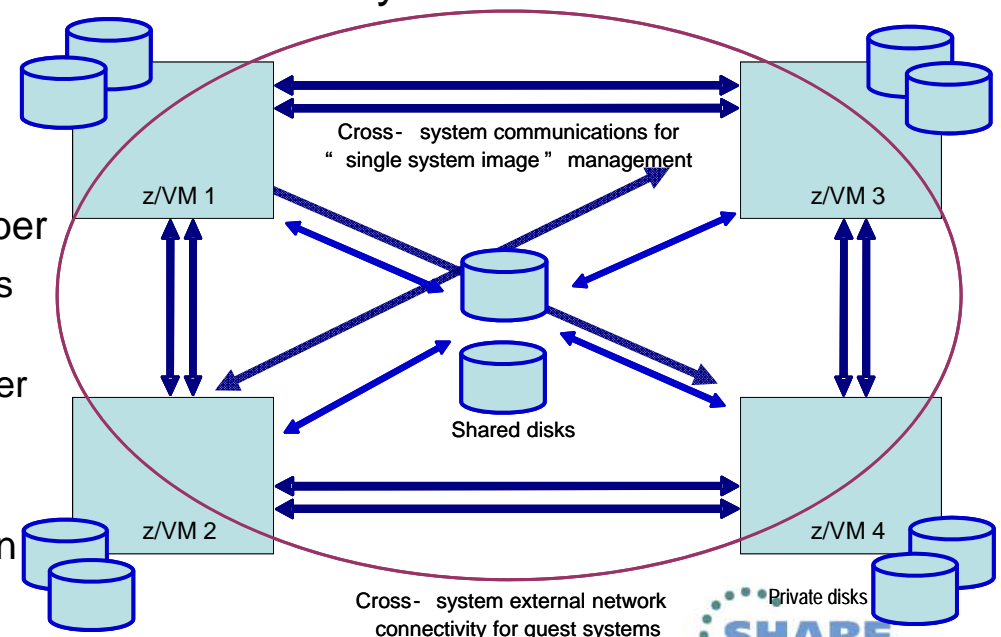

## Non-SSI Install

- SSI ready
  - DASD layout
  - Directory format
  - Minidisk layout
- Install on ECKD or SCSI LUNs
  - SSI requires z/VM install on ECKD
  - 3390-9 6 volumes
  - 3390-3 10 volumes

# Migration to SSI

- Prepare member specific user volume
  - Used to convert single configuration user to multiconfiguration user
- Update System Config file
  - Add SSI statements
  - Qualify statements
- Update User Directory
- Manage user spool files
- Prepare CP-Owned volumes
  - Add ownership information
  - Create Persistent Data Record on common volume
- Modify startup parameters of cluster wide sfs pool (vmppsfs)
- Shutdown and cold start
- Load spool files
- Change USER DIRECT to SSI Enabled
- Clean up

# Clone Member to Create Second SSI Member

- Second member requires 6 3390-3 or 4 3390-9 system volumes
  - Also member specific user volume
- Prepare CP-Owned volumes for member 2
- Create TCP/IP config for member 2
- Update config files for other service machines
- Update AUTOLOG1
- Copy source system and member specific user volumes to target volumes
- Update DIRMAINT config
- Update USER DIRECT
- Update SYSTEM CONFIG
- Configure CTCAs between members
- IPL member 2
- Update VMSES/E inventory
- Build saved segments and NSS
- Start service virtual machines
- Test and verify

# Upgrade Installation

- New for z/VM 6.3
- Limited to migrations from z/VM 6.2 (non-SSI or SSI)
- Addresses problems with traditional migration in SSI clusters
  - Supports upgrading one member at a time
  - Minimal disruption of the source system being migrated
  - Ensures that z/VM 6.3 levels of cluster wide tools are available to all members of the cluster
    - E.g. DIRECTXA, CPFMTXA ...
- Most additional DASD needed for upgrade can be returned to DASD pool after upgrade



# LAB Environment

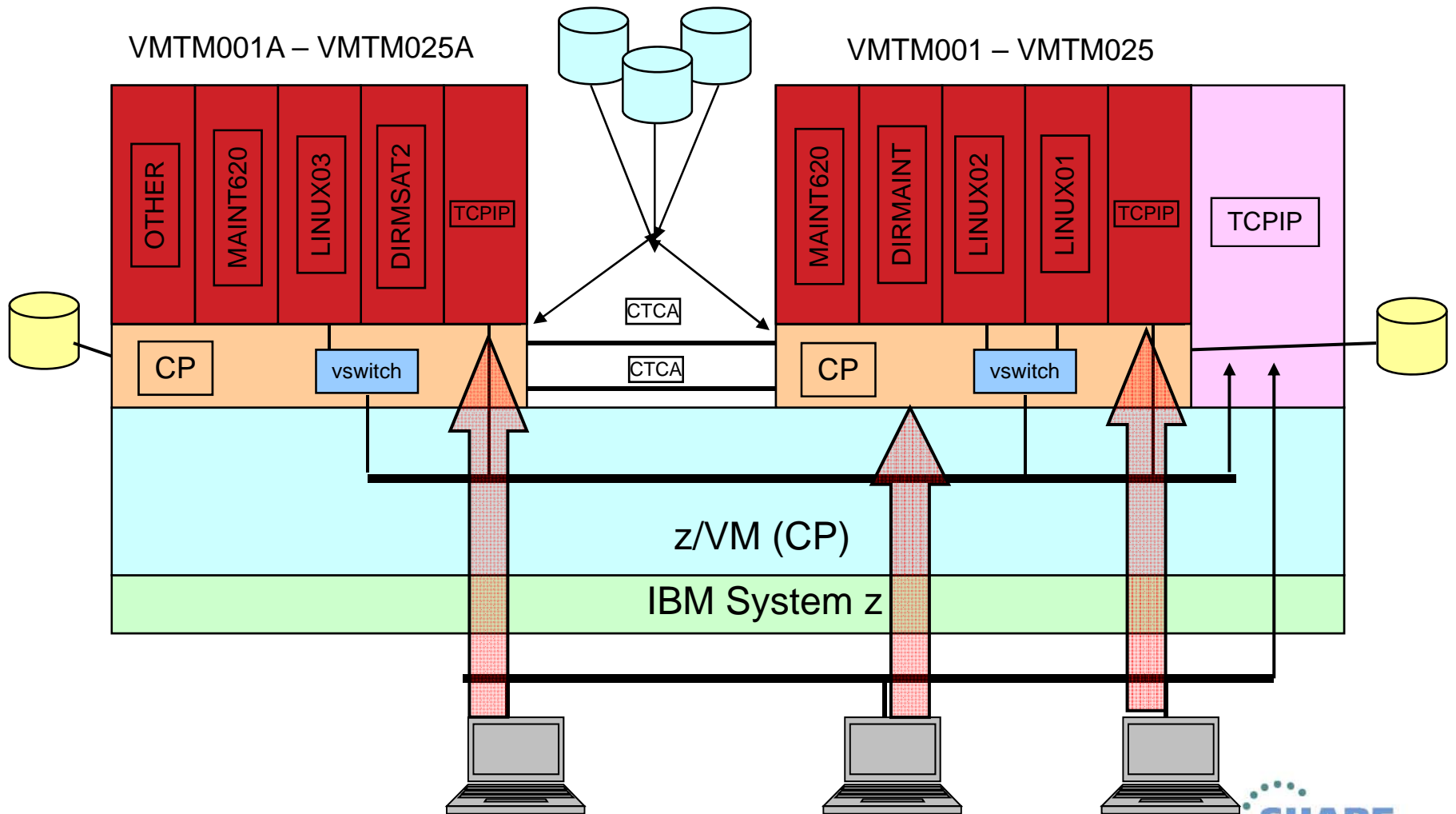

# Trademarks



**The following are trademarks of the International Business Machines Corporation in the United States, other countries, or both.**

Not all common law marks used by IBM are listed on this page. Failure of a mark to appear does not mean that IBM does not use the mark nor does it mean that the product is not actively marketed or is not significant within its relevant market.

Those trademarks followed by ® are registered trademarks of IBM in the United States; all others are trademarks or common law marks of IBM in the United States.

For a complete list of IBM Trademarks, see [www.ibm.com/legal/copytrade.shtml](http://www.ibm.com/legal/copytrade.shtml):

\*, AS/400®, e business (logo)®, DBE, ESCO, eServer, FICON, IBM®, IBM (logo)®, iSeries®, MVS, OS/390®, pSeries®, RS/6000®, S/30, VM/ESA®, VSE/ESA, WebSphere®, xSeries®, z/OS®, zSeries®, z/VM®, System i, System i5, System p, System p5, System x, System z, System z9®, BladeCenter®

**The following are trademarks or registered trademarks of other companies.**

Adobe, the Adobe logo, PostScript, and the PostScript logo are either registered trademarks or trademarks of Adobe Systems Incorporated in the United States, and/or other countries.

Cell Broadband Engine is a trademark of Sony Computer Entertainment, Inc. in the United States, other countries, or both and is used under license therefrom.

Java and all Java-based trademarks are trademarks of Sun Microsystems, Inc. in the United States, other countries, or both.

Microsoft, Windows, Windows NT, and the Windows logo are trademarks of Microsoft Corporation in the United States, other countries, or both.

Intel, Intel logo, Intel Inside, Intel Inside logo, Intel Centrino, Intel Centrino logo, Celeron, Intel Xeon, Intel SpeedStep, Itanium, and Pentium are trademarks or registered trademarks of Intel Corporation or its subsidiaries in the United States and other countries.

UNIX is a registered trademark of The Open Group in the United States and other countries.

Linux is a registered trademark of Linus Torvalds in the United States, other countries, or both.

ITIL is a registered trademark, and a registered community trademark of the Office of Government Commerce, and is registered in the U.S. Patent and Trademark Office.

IT Infrastructure Library is a registered trademark of the Central Computer and Telecommunications Agency, which is now part of the Office of Government Commerce.

\* All other products may be trademarks or registered trademarks of their respective companies.

## Notes:

Performance is in Internal Throughput Rate (ITR) ratio based on measurements and projections using standard IBM benchmarks in a controlled environment. The actual throughput that any user will experience will vary depending upon considerations such as the amount of multiprogramming in the user's job stream, the I/O configuration, the storage configuration, and the workload processed. Therefore, no assurance can be given that an individual user will achieve throughput improvements equivalent to the performance ratios stated here.

IBM hardware products are manufactured from new parts, or new and serviceable used parts. Regardless, our warranty terms apply.

All customer examples cited or described in this presentation are presented as illustrations of the manner in which some customers have used IBM products and the results they may have achieved. Actual environmental costs and performance characteristics will vary depending on individual customer configurations and conditions.

This publication was produced in the United States. IBM may not offer the products, services or features discussed in this document in other countries, and the information may be subject to change without notice. Consult your local IBM business contact for information on the product or services available in your area.

All statements regarding IBM's future direction and intent are subject to change or withdrawal without notice, and represent goals and objectives only.

Information about non-IBM products is obtained from the manufacturers of those products or their published announcements. IBM has not tested those products and cannot confirm the performance, compatibility, or any other claims related to non-IBM products. Questions on the capabilities of non-IBM products should be addressed to the suppliers of those products.

Prices subject to change without notice. Contact your IBM representative or Business Partner for the most current pricing in your geography.



Complete your sessions evaluation online at [SHARE.org/BostonEval](http://SHARE.org/BostonEval)

