



# Planning your CICS TS V5.1 Upgrade

Steve Zemblowski  
zem@us.ibm.com





© IBM Corporation 2012. All Rights Reserved.

The workshops, sessions and materials have been prepared by IBM or the session speakers and reflect their own views. They are provided for informational purposes only, and are neither intended to, nor shall have the effect of being, legal or other guidance or advice to any participant. While efforts were made to verify the completeness and accuracy of the information contained in this presentation, it is provided AS IS without warranty of any kind, express or implied. IBM shall not be responsible for any damages arising out of the use of, or otherwise related to, this presentation or any other materials. Nothing contained in this presentation is intended to, nor shall have the effect of, creating any warranties or representations from IBM or its suppliers or licensors, or altering the terms and conditions of the applicable license agreement governing the use of IBM software.

References in this presentation to IBM products, programs, or services do not imply that they will be available in all countries in which IBM operates. Product release dates and/or capabilities referenced in this presentation may change at any time at IBM's sole discretion based on market opportunities or other factors, and are not intended to be a commitment to future product or feature availability in any way. Nothing contained in these materials is intended to, nor shall have the effect of, stating or implying that any activities undertaken by you will result in any specific sales, revenue growth or other results.

Performance is based on measurements and projections using standard IBM benchmarks in a controlled environment. The actual throughput or performance that any user will experience will vary depending upon many factors, including considerations such as the amount of multiprogramming in the user's job stream, the I/O configuration, the storage configuration, and the workload processed. Therefore, no assurance can be given that an individual user will achieve results similar to those stated here.

All customer examples described are presented as illustrations of how those customers have used IBM products and the results they may have achieved. Actual environmental costs and performance characteristics may vary by customer.

The following are trademarks of the International Business Machines Corporation in the United States and/or other countries:

ibm.com/legal/copytrade.shtml, AIX, CICS, CICSplex, DataPower, DB2, DB2 Universal Database, i5/OS, IBM, the IBM logo, IMS/ESA, Power Systems, Lotus, OMEGAMON, OS/390, Parallel Sysplex, pureXML, Rational, Redbooks, Sametime, SMART SOA, System z, Tivoli, WebSphere, and z/OS.

A current list of IBM trademarks is available on the Web at "Copyright and trademark information" at [ibm.com/legal/copytrade.shtml](http://ibm.com/legal/copytrade.shtml).

Adobe, the Adobe logo, PostScript, and the PostScript logo are either registered trademarks or trademarks of Adobe Systems Incorporated in the United States, and/or other countries.

IT Infrastructure Library is a registered trademark of the Central Computer and Telecommunications Agency which is now part of the Office of Government Commerce

Java and all Java-based trademarks are trademarks of Sun Microsystems, Inc. in the United States, other countries, or both.

Microsoft and Windows are trademarks of Microsoft Corporation in the United States, other countries, or both.

ITIL is a registered trademark, and a registered community trademark of the Office of Government Commerce, and is registered in the U.S. Patent and Trademark Office

Intel and Pentium are trademarks or registered trademarks of Intel Corporation or its subsidiaries in the United States and other countries.

UNIX is a registered trademark of The Open Group in the United States and other countries.

Linux is a registered trademark of Linus Torvalds in the United States, other countries, or both.



# Session Agenda

- Statements of Direction
- Software prerequisites
- General external changes
  - Resource definition
  - Application and systems programming interfaces
  - Global user exits
  - Monitoring and statistics
- Upgrade Process
- Stabilization of support and discontinued functions
- Documentation
- Summary





# Notes

- This presentation is assuming the user is upgrading from CICS TS 4.2 to CICS TS 5.1 and so describes the upgrade process between those two releases.
- The CICS Information Center provides four Upgrades Guides, showing
  - Upgrading from 3.1 to 5.1
  - Upgrading from 3.2 to 5.1
  - Upgrading from 4.1 to 5.1
  - Upgrading from 4.2 to 5.1

# Statements of Directions

- SUPPORT

- To assist customers in their planning process, IBM is making the following statement of direction about IBM CICS Transaction Server for z/OS (CICS TS):
  - IBM intends to continue to support both CICS TS V3.1 and CICS TS V3.2 until at least 3Q 2014, providing more than 9 years of support for the overall version since its initial introduction.
    - ***Effective December 31, 2015, IBM will discontinue support for the following programs:***
      - *5655-M15 CICS Transaction Server for z/OS V3.1*
      - *5655-M15 CICS Transaction Server for z/OS V3.2*
  - IBM intends to continue to support both CICS TS V4.1 and CICS TS V4.2 **until at least 3Q 2017**, providing more than 8 years of support for the overall version since its initial introduction.

# Notes

IBM declares the following statements of general direction:

To assist customers in their planning process, IBM makes the following statements of direction for IBM CICS TS for z/OS :

- IBM intends to continue to support both CICS TS V3.1 and CICS TS V3.2 until at least third quarter, 2014. This provides more than nine years of support for the overall version since its initial introduction.
- IBM intends to continue to support both CICS TS V4.1 and CICS TS V4.2 until at least third quarter, 2017. This provides more than eight years of support for the overall version since its initial introduction.

IBM 's statements regarding its plans, directions, and intent are subject to change or withdrawal without notice at IBM 's sole discretion. Information regarding potential future products is intended to outline our general product direction and it should not be relied on in making a purchasing decision. The information mentioned regarding potential future products is not a commitment, promise, or legal obligation to deliver any material, code or functionality. Information about potential future products may not be incorporated into any contract. The development, release, and timing of any future features or functionality described for our products remains at our sole discretion.



# Statements of direction in CICS TS 5.1 announcement October 3<sup>rd</sup> 2012



- IBM intends in the future to enhance the IBM Geographically Dispersed Parallel Sysplex (GDPS)/Active-Active continuous availability solution by providing support for software replication of Virtual Storage Access Method (VSAM) data for active-standby and active-query configurations. IBM plans to provide such support for data replication for VSAM data updated by applications running in CICS and offline in batch mode, using log data provided by IBM CICS Transaction Server for z/OS V5.1, or later, and IBM CICS VSAM Recovery for z/OS V5.1, or later.
- IBM intends for future maintenance roll-ups of IBM 31-bit and 64-bit SDK7 for z/OS Java Technology Edition, Version 7, to provide exploitation of new IBM zEnterprise EC12 features. This includes IBM z/OS V1.13, Flash Express for paging and pageable large pages, Transactional-Execution facility, miscellaneous-instruction-extension facility, and support for up to 2 GB-sized pages, leading to potential improvements in performance for Java applications running in a CICS environment.



# Notes

- IBM declares the following statements of general direction:
- IBM intends in the future to enhance the IBM Geographically Dispersed Parallel Sysplex (GDPS)/Active-Active continuous availability solution by providing support for software replication of Virtual Storage Access Method (VSAM) data for active-standby and active-query configurations. IBM plans to provide such support for data replication for VSAM data updated by applications running in CICS and offline in batch mode, using log data provided by IBM CICS Transaction Server for z/OS V5.1, or later, and IBM CICS VSAM Recovery for z/OS V5.1, or later.
- IBM intends for future maintenance roll-ups of IBM 31-bit and 64-bit SDK7 for z/OS Java Technology Edition, Version 7, to provide exploitation of new IBM zEnterprise EC12 features. This includes IBM z/OS V1.13, Flash Express for paging and pageable large pages, Transactional-Execution facility, miscellaneous-instruction-extension facility, and support for up to 2 GB-sized pages, leading to potential improvements in performance for Java applications running in a CICS environment.
- IBM's statements regarding its plans, directions, and intent are subject to change or withdrawal without notice at IBM's sole discretion. Information regarding potential future products is intended to outline our general product direction and it should not be relied on in making a purchasing decision. The information mentioned regarding potential future products is not a commitment, promise, or legal obligation to deliver any material, code or functionality. Information about potential future products may not be incorporated into any contract. The development, release, and timing of any future features or functionality described for our products remains at our sole discretion.



# CICS Developer Trial



Announced Oct 3rd 2012, available from Jan 13<sup>th</sup> 2013

- No charge trial, fixed expiry date
- Does not start SVC period
- For non-production environments
- Available through IBM ShopzSeries
- PID 5655-Y30

Based on CICS TS V5.1 (with restrictions)

- Performance
- Capacity
- License

CICSDev Community:

<https://www.ibm.com/developerworks/connect/cicsdev>

# Notes

- Licensing Terms and Conditions - designated as "Non-Production" and can only be deployed as part of an internal development and test environment for non-production activities.
- Technical restrictions - relating to performance and capacity. These restrictions will not inhibit the exploration of the latest features and capabilities. However, they will significantly limit the overall workload that can be run in the system at any given time. For more details visit the CICS TS Developer Trial Information Center (see section Information Centers and publications).
- Fixed expiry date - providing at least 90 days operation from the date of fulfillment. New releases can be installed to extend this period. There is no limit to the number of times CICS TS Developer trial can be reordered, installed and used.
- Program support restrictions - formal program support is not provided with CICS TS Developer Trial. Support enquiries can be submitted via a IBM developerWorks forum. Updated releases of CICS TS Developer Trial V5.1, containing the latest service fixes, will be made available by IBM periodically

# CICS Transaction Server V5.1 Elements

- CICS Transaction Server V5.1
  - CICS 0680
  - Service Flow Runtime
- CICSplex SM V5.1
- REXX
  - Development System
  - Runtime Facility
  - REXX Common for z/OS
- Available via download
  - CICS Explorer V5.1.1
  - CICS Information Center V5.1



# Notes

- The base CICS element of CICS TS V5.1 is CICS V6.8. The CICSplex SM element is CICSplex SM V5.1.
- Other elements of CICS TS V5.1, that were previously available as separate IBM products, are:
  - CICS REXX Runtime Facility
  - CICS REXX Development System
  - CICS REXX Common for z/OS
- CICS TS V5.1 is shipped with CICS Service Flow Runtime, previously only available as a separately orderable feature, which allows the deployment of CICS business services (or service flows) created by the Service Flow Modeler component of IBM Rational Developer for System z, V7.5 or later. The service flow runtime capability of CICS TS V5.1 is fully compatible with IBM CICS Service Flow Feature V3.2. Customers upgrading to CICS TS V5.1 might use the integrated support for business services in this release as a direct replacement for IBM CICS Service Flow Feature V3.2.

# Software prerequisites

- CICS TS V5.1 requires z/OS V1.13, or later
  - The product will not initialize with a lower level of operating system installed
- IBM 64-bit SDK for z/OS, Java Technology Edition V7.0.0
  - Required if using Java application programs, the CICS Web Services Assistant, the CICS XML Assistant or validation of web services/XML transforms
- The IBM XML Toolkit V1.10 for z/OS is not required for installation
  - Required at runtime if WS-Security is used
    - Apply also apar OA14956
  - If not present at runtime DFHPI0119 will be issued
- ***IBM XML Toolkit and Java SDK NOT shipped with CICS***

# Notes

- z/OS V1.13 or later is required. CICS TS V5.1 will not initialize in an environment with a lower level of operating system installed.
- The IBM 64-bit SDK for z/OS, Java Technology Edition V7.0.0 or later, is required if using Java application programs, or the CICS Web Services Assistant. The IBM SDK for z/OS is available, without charge, on tape or by download from:
  - <http://www.ibm.com/servers/eserver/zseries/software/java/>



# Software prerequisites...

- CICS Tools
  - CICS Performance Analyzer V5.1
  - CICS Interdependency Analyzer V5.1
  - CICS Configuration Manager V5.1
  - CICS Deployment Assistant V5.1
  - CICS VSAM Recovery V5.1
- CICS Transaction Gateway V7.1 or later
- IMS V11 or later
  - 11 with PM31729
  - 12 with PM31420, PM45414, PM47327, PM60830 and PM67188 for threadsafe support
- DB2 V9.1 or later
- WebSphere MQ V7.0.1 or later
- WebSphere Application Server for z/OS V7.0 or later
- Current pre-requisite levels will be maintained at:
  - [IBM Prerequisites](#)

# Notes

- The support page will be located at:
- <http://www.ibm.com/support/docview.wss?uid=swg27035673>



## Compiler Best Practices

- Upgrade compilers when you upgrade System z hardware or Middleware
  - Minimize quality assurance effort
  - Maximize performance
  - Leverage compiler support for new middleware features
  - Improve debugging and programmability
- Recompile “hot spots” to improve performance
- Leverage new compiler features to modernize critical applications
  - “Rip and Replace is expensive and risky
  - Modernization promotes reuse and delivery of new solution at lower cost, lower risk and shorter delivery time
- Use Rational development tools to improve programmer productivity
  - Rational Developer for z, Rational Developer for z UT, Rational Team Concert



# Notes

- This page intentionally left blank.



# Business Partner Software

***The information contained on the Business Partner Offerings pages and any associated documentation was supplied by various third parties, and was not authored by IBM; it is provided by IBM for informational purposes only. To the fullest extent permitted under applicable law, the information contained on the Business Partner Offerings pages and any associated documentation is made available by IBM and (where relevant) by the named IBM Business Partner on "as is" basis, without warranty of any kind, express or implied. IBM shall not be responsible for any damages arising out of the use of, or otherwise related to, the information on the Business Partner Offerings pages or in any other related documentation. Nothing contained on the Business Partner Offerings pages or in such documentation is intended to, or shall have the effect of, creating any warranty or representation from IBM (or any of IBM's Business Partners, suppliers or licensors), or altering the terms and conditions of the applicable license agreement governing the use of any IBM software. The IBM Business Partner statements on the Business Partner Offerings pages or in such documentation do not necessarily represent the positions, strategies or opinions of IBM; those statements are provided only to illustrate how various IBM Business Partners use or support various IBM software products. No guarantee of comparable results is offered, either by IBM or by any of its Business Partners, suppliers or licensors.***

- Current business partner support will be maintained at:
  - [Business Partner Software](#)

# Notes

- The business partner products page for CICS TS V51 is located at:
- <http://www.ibm.com/software/htp/cics/partners.html>





# z/OS Storage

- 64-bit storage
  - Above the 2 gigabyte **bar**
- 31-bit storage
  - Above the line 16 megabyte **line**
  - Below the 2 gigabyte bar
- 24-bit storage
  - Below the line 16 megabyte line

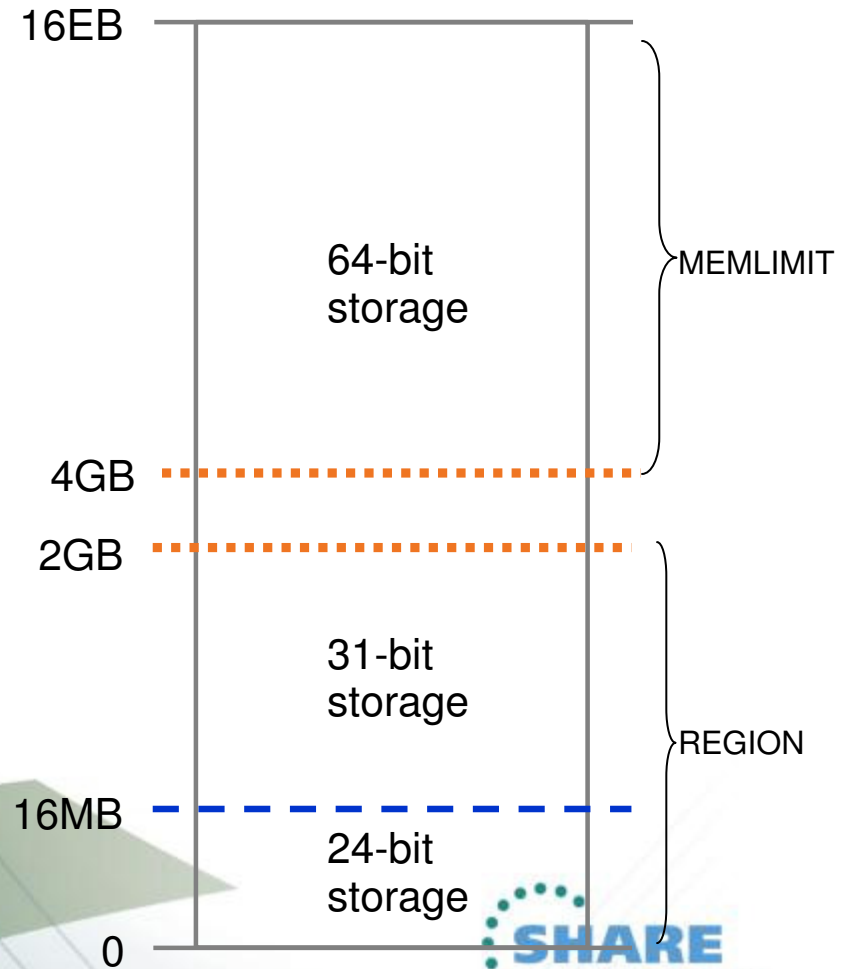

# Notes

CICS uses and manages virtual storage in three areas of its z/OS address space:

Storage below the line (0 MB to 16 MB)

- The storage in this area is 24-bit storage. Addresses below the 16 MB address are accessed by 24-bit addressing, and programs can use this storage when they run in AMODE 24 or higher. The 16 MB address is known as the line, so 24-bit storage is also called storage below the line.
- Storage above the line (16 MB to 2 GB)
- The storage in this area is 31-bit storage. Addresses above the 16 MB address but below the 2 GB address are accessed by 31-bit addressing, and programs can use this storage when they run in AMODE 31 or higher. The 16 MB address is known as the line, so 31-bit storage is also called storage above the line. The area that separates the virtual storage area below the 2 GB address from the user private area is known as the bar. 24-bit and 31-bit storage are in storage below 2 GB and can together be referred to as storage below the bar.
- Storage above the bar (4 GB to a theoretical 16 exabytes)
- The storage in this area is 64-bit storage. The area that separates the virtual storage area below the 2 GB address from the user private area is known as the bar, and 64-bit storage is also known as storage above the bar. The storage above the bar comprises a user private area between 4 GB and 2 terabytes, a shared area between 2 terabytes and 512 terabytes, and a user private area between the end of the shared area and 16 exabytes.

# CICS TS V5.1 Usage of 24 and 31 Bit Storage

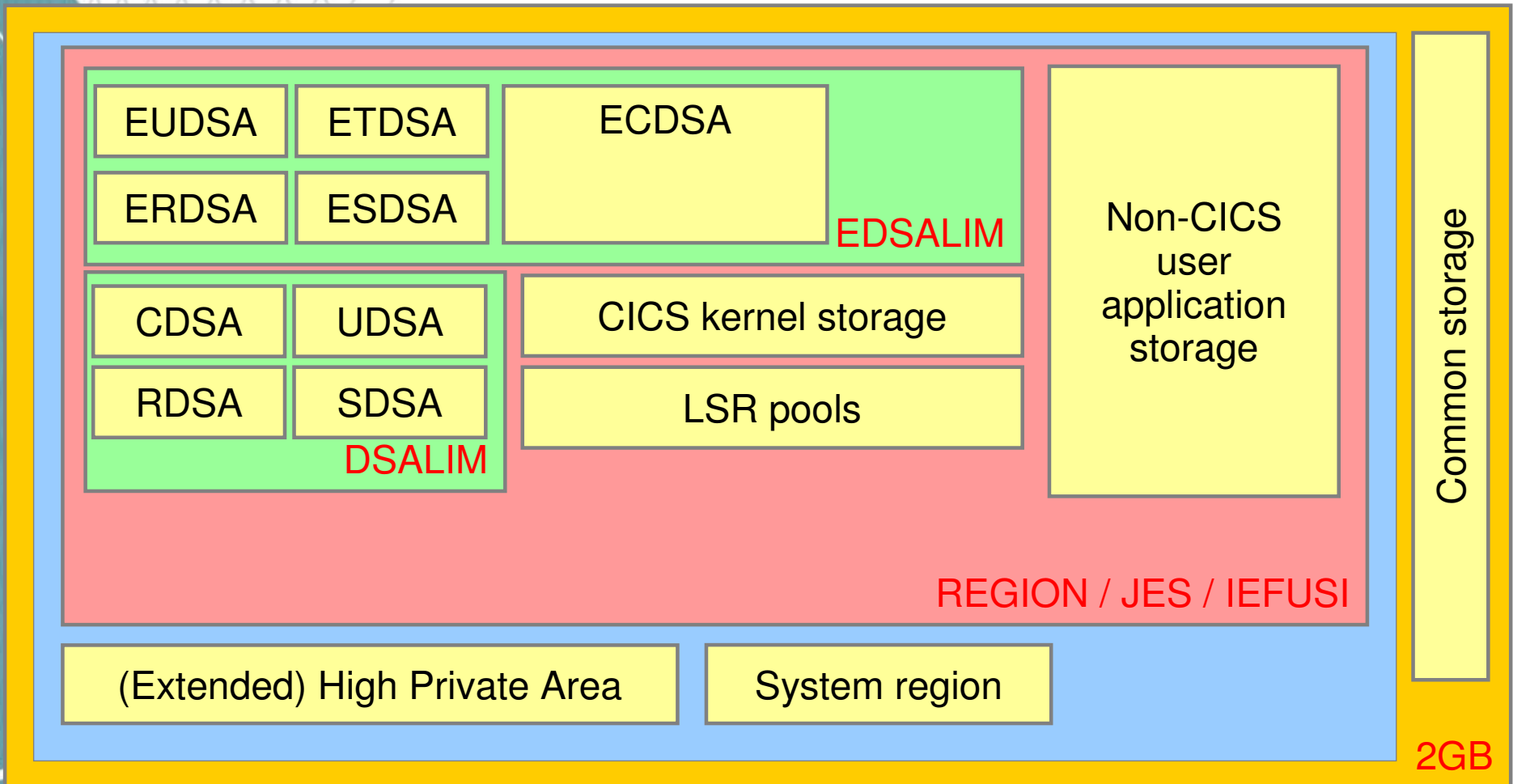



# Notes

- **Color key:**
- Orange area is 31-bit addressability limit
- Blue area is private storage
- Red area is storage limit defined by JCL REGION parameter / JES defaults / IEFUSI
- Green areas are CICS dynamic storage areas
- Red text indicates limiting factor for each area
- White are storage areas moved

# CICS TS V5.1 Usage of 64 Bit Storage

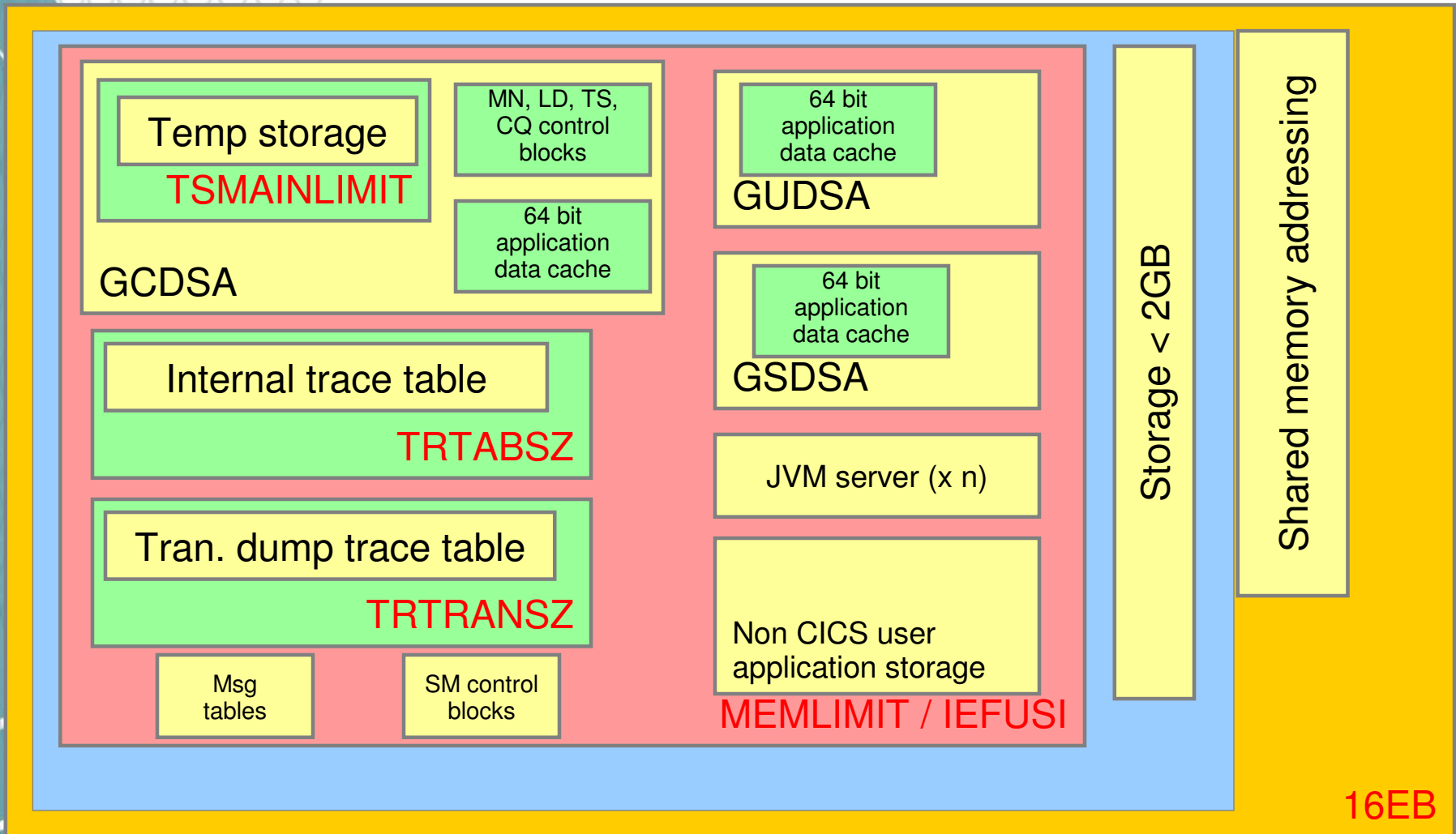

# Notes

- **Color key:**
- Orange area is 64-bit addressability limit
- Blue area encompasses all private storage
- Red area is storage limit defined by JCL MEMLIMIT parameter / IEFUSI
- Red text indicates limiting factor for each area



# External Changes...

- MEMLIMIT
  - CICS TS V5.1 requires a minimum of **6GB**
  - DFHSM0602 message is issued and CICS terminates
    - if MEMLIMIT is less than 6GB
  - Above bar storage usage
    - Main Temporary storage
      - *Minimum 1MB*
      - *Limited to 25% of MEMLIMIT*
    - Channels and containers
      - *Limited to 5% of MEMLIMIT*
    - Internal Trace Table
      - *Minimum 16KB*
      - *Maximum 1GB*
    - Transaction Dump Table (TRTRANSZ SIT parameter)
      - *Minimum 16KB*
      - *Maximum 1GB*
    - Console Queue Processing Trace table
    - Console Queue Transaction Entry table
    - Some LD domain control blocks
    - Some SM domain control blocks
    - Application data cached using Amode 64 GETMAIN

# Notes

- To provide sufficient 64-bit (above-the-bar) storage for a CICS® TS V5.1 region, set the value for the z/OS MEMLIMIT parameter equal to or greater than 6 GB. The default value in z/OS for MEMLIMIT is 2 GB.
- A CICS region requires at least 6 GB of 64-bit storage. You cannot start a CICS region with a MEMLIMIT value that is lower than 6 GB. If you attempt to do so, message DFHSM0602 is issued, a system dump with the dump code KERNDUMP is produced, and CICS terminates.
- You cannot alter the MEMLIMIT value for the CICS region while CICS is running. You can specify a new MEMLIMIT value on the next start of the CICS region.

## External Changes...

- JAVADIR parameter
  - Default value has changed in the installation procedures
  - java/J7.0\_64
- Release levels
  - INQUIRE SYSTEM RELEASE returns 0680
  - Utility programs suffixed with 680
    - e.g. DFHPD680
- STEPLIB concatenation
  - SEYUAUTH **must** be in the concatenation even if CPSM is not used



# Notes

The default location for Java has changed to support the Java 7 64-bit JVM.

- The default value for the JAVADIR parameter in the installation procedures has changed to java/J7.0\_64. You must download the IBM® 64-bit SDK for z/OS®, Java Technology Edition and configure CICS® to point to the correct location in z/OS UNIX.
- You use the EXEC CICS INQUIRE SYSTEM CICSTSLEVEL command to determine the version and release number of CICS. Use the EXEC CICS INQUIRE SYSTEM OSLEVEL command to determine the level of z/OS.
- To ensure compatibility with previous releases, the CICS base element maintains its own level (identification) number. Each time new function is added to CICS and shipped with the CICS Transaction Server product, the CICS level number is incremented.
- The CICS level number in CICS TS V5.1 is 0680. This number is returned in the RELEASE parameter of the INQUIRE SYSTEM command.
- The level number also appears in the alternative decimal form 6.8 in output from offline utilities such as statistics and dump formatters to identify the level of utility being used, and as the suffix in module names such as DFHPD680.
- SEYUAUTH must be in the STEPLIB concatenation list even if CPSM is not being used. During initialization CICS will attempt to load the CICS and CPSM message tables.

# External Changes...

- New System Initialization parameters
  - RACFSYNC={YES|NO}
    - The RACFSYNC system initialization parameter specifies whether CICS listens for type 71 ENF events
  - SECVFYFREQ={NEVER|USRDELAY}
    - The SECVFYFREQ system initialization parameter specifies whether or not CICS makes a full verification request at least once a day for each user ID that is used to log on to the CICS region
- Changed System Initialization parameters
  - AKPFREQ={4000|number}
    - Minimum lowered from 200 to 50
  - AUTORESETTIME={IMMEDIATE|NO|YES}
    - A new option, IMMEDIATE, now synchronizes the time at the next task attach. The IMMEDIATE option is the default
  - EDSALIM={800M|number}
    - Default changed from 48MB to 800MB
  - ICVTSD={0|number}
    - Default changed to 0

# Notes

RACF sends a type 71 ENF signal to listeners when a CONNECT, REMOVE, or REVOKE command changes a user's resource authorization. When CICS receives a type 71 ENF event for a user ID, all cached user tokens for the user ID are invalidated, irrespective of the setting of the USRDELAY parameter. Subsequent requests from that user ID force a full RACF RACROUTE VERIFY request, which results in a refresh of the user's authorization level. User tokens for tasks that are currently running are not affected.

- When a user logs on to CICS by a method that uses password verification, such as the EXEC CICS VERIFY PASSWORD or EXEC CICS VERIFY PHRASE command, instead of a full verification request such as the EXEC CICS SIGNON command, RACF normally does not record the login, and does not write audit information for the user ID. You can use SECVFYFREQ to require that CICS makes a full verification request for each user at least once a day. The full verification request makes RACF record the date and time of last access for the user ID, and write user statistics.
- The minimum value in the activity keypoint frequency range is reduced from 200 to 50. The activity keypoint frequency is set by using AKPFREQ system initialization parameter. The reduced minimum value means that completed log task records can be deleted more frequently, which reduces the DASD dataspace usage. Therefore, the primary system logstream remains at a reasonable size.
- Before CICS TS for z/OS, Version 5.1, the CICS time-of-day was synchronized with the system time-of-day only at midnight. A new option, IMMEDIATE, now synchronizes the time at the next task attach. The IMMEDIATE option is the default.
- The EDSALIM system initialization parameter specifies the upper limit of the total amount of storage within which CICS can allocate the individual extended dynamic storage areas (EDSAs) that reside in 31-bit (above-the-line) storage. Before CICS TS for z/OS, Version 5.1, the default value for this system initialization parameter was set at the minimum required to start a CICS region, which is 48 MB. The default value is now increased to 800 MB, which enables a CICS region started with the default value to process a reasonable workload. You can tune the EDSALIM value in a running CICS system.
- Before CICS TS for z/OS, Version 5.1, the default value for the ICVTSD system initialization parameter, which specifies the terminal scan delay time, was 500 milliseconds. In CICS TS for z/OS, Version 5.1, the default value is 0. The terminal scan delay facility was used in earlier releases to limit how quickly CICS dealt with some types of terminal output requests made by applications, in order to spread the overhead for dealing with the requests. Specifying a nonzero value was sometimes appropriate where the CICS system used non-SNA networks. However, with SNA and IPIC networks, setting ICVTSD to 0 is appropriate to provide a better response time and best virtual storage usage. .



# External Changes...

- Changed System Initialization parameters
  - MXT={500|*number*}
    - Maximum tasks limit increased from 999 to 2000
    - Default value changed from 5 to 500
    - Minimum increased from 1 to 10
  - PRTYAGE={1000|*value*}
    - Default changed from 32768ms to 1000ms
  - SPCTRxx={(1,2)|(1[,2][,3][,4])|ALL|OFF}
    - A new component code (MP) has been added to support the special tracing levels for the managed platform domain.
  - STATINT={010000|*hhmmss* }
    - Default changed from 030000 to 010000 (hhmmss)
  - STNTRxx={1|(1[,2][,3][,4])|ALL|OFF}
    - A new component code (MP) has been added to support the standard tracing levels for the managed platform domain.
  - TBEXITS=(*[name1][,name2][,name3][,name4][,name5][,name6]*)
    - These global user exit programs are now enabled with a global work area of 4 bytes in 31-bit (above-the-line) storage.



# Notes

Before CICS TS for z/OS, Version 5.1, the minimum, default, and maximum values of the MXT parameter were 1, 5, and 999 respectively. The minimum value is now increased to 10, the default value is increased to 500, and the maximum value is increased to 2000. These changes mean that a CICS region operates more efficiently with the default setting and can process more workload.

- Before CICS TS for z/OS, Version 5.1, the default value for the PRTYAGE parameter was 32768 (32.768 seconds). The default value is now decreased to 1000 (1 second). This value means that the priority of long-running tasks that are on the ready queue will increase more rapidly.
- A new component code (MP) has been added to support the special tracing levels for the managed platform domain. The special tracing level numbers 29, 30, 31, and 32 that traced the SJ component for Java are obsolete.
- Before CICS TS for z/OS, Version 5.1, the default value of the STATINT parameter was 030000 (3 hours). The default value is now changed to 010000 (1 hour), so that useful CICS system and resource data is collected more frequently.
- A new component code (MP) has been added to support the standard tracing levels for the managed platform domain. The trace levels 29, 30, 31, and 32 are obsolete and no longer traced.
- The TBEXITS system initialization parameter enables specified global user exit programs as backout exit programs. The backout exit programs are used during emergency restart backout for user log record recovery and file control recovery. In releases earlier than CICS TS for z/OS, Version 5.1, these global user exit programs were enabled with a global work area of 4 bytes in 24-bit (below-the-line) storage. These global user exit programs are now enabled with a global work area of 4 bytes in 31-bit (above-the-line) storage.

# External Changes...

- Changed System Initialization parameters
  - TCTUALOC={BELOW|ANY}
    - Default changed from TCTUALOC=BELOW to TCTUALOC=ANY
  - TRTRANSZ={1024|*number-of-kilobytes*}
    - Default increased from 16K to 1024K (1MB)
    - Trace table is in 64-bit storage
    - Giving much better chance of tracing the error before a dump
- Obsolete System Initialization parameters
  - EJBROLEPRFX
    - EJB support has been removed
  - IIOPLISTENER
    - IIOPL support has been removed
  - JVMCCSIZE
  - JVMCCSTART
  - JVMLEVEL0TRACE
  - JVMLEVEL1TRACE
  - JVMLEVEL2TRACE
  - JVMUSERTRACE
    - Pooled JVM support has been removed

# Notes

- Before CICS TS for z/OS, Version 5.1, the default value for the TCTUALOC parameter was BELOW, which meant that terminal user areas were always stored in 24-bit (below-the-line) storage. The default value is now ANY, which means that terminal user areas can be stored in 24-bit (below-the-line) storage or in 31-bit (above-the-line) storage, and CICS uses 31-bit storage to store them if possible. If you require the terminal user area to be in 24-bit storage, because you have application programs that are not capable of 31-bit addressing, specify the system initialization parameter TCTUALOC=BELOW for the CICS region.

Before CICS TS for z/OS, Version 5.1, the default value of the TRTRANSZ parameter was 16 KB. The default value is now increased to 1024 KB. This value provides a larger transaction dump trace table, which might contain more useful trace information. Check your current setting for the z/OS parameter MEMLIMIT, which limits the amount of 64-bit storage that the CICS address space can use. Your setting for TRTRANSZ must remain within MEMLIMIT, and you must also allow for other use of 64-bit storage in the CICS region. Also check the current space allocations for the CICS transaction dump data sets. Increase the amount of space currently allocated to match the new value.

- IIOP and Pooled JVM support has been removed, so all SIT parms related to IIOP and pooled JVM support are obsolete.



# External Changes...

- **Obsolete System Initialization parameters**
  - **MAXOPENTCBS**
    - Parameter obsolete
    - Set internally to a value of  $((MXT * 2) + 32)$
  - **MAXXPTCBS**
    - Parameter obsolete
    - Set internally to the value of MXT
  - **MAXJVMTCBS**
    - Parameter obsolete, support for pooled JVMs has been removed
  - **TDSUBTASK**
    - If on QR TCB TD will switch to FO TCB, If on an open TCB it uses the open TCB
  - **XEJB**
    - EJB support has been removed



# Notes

- Before CICS TS for z/OS, Version 5.1, you used the MAXOPENTCBS and MAXXPTCBS system initialization parameters to set limits for the number of open TCBs in the CICS region. MAXOPENTCBS specified the maximum number of open TCBs in the pool of L8 and L9 mode TCBs, which are used for OPENAPI application programs and task-related user exits that are enabled with the OPENAPI option. MAXXPTCBS specified the maximum number of open TCBs in the pool of X8 and X9 mode TCBs, which are used for C and C++ programs compiled with the XPLINK option.
- CICS now automatically sets and changes the limits for open TCBs in these TCB pools when you set or change the maximum number of tasks (MXT or MAXTASKS) specified for the CICS region. For the limit on the L8 and L9 mode open TCB pool, CICS uses the following formula:  $(2 * \text{MXT Value}) + 32$  For the limit on the XP TCB pool, CICS uses a value equal to the MXT value for the CICS region
- EJB support has been removed so security parm XEJB is obsolete

# External Changes...



- **Obsolete Resource Definitions**
  - **CORBASERVER**
    - The CORBASERVER resource, used for defining the execution environment for enterprise beans and stateless CORBA objects, is obsolete and is removed.
  - **DJAR**
    - The DJAR resource, used for defining a deployed JAR file in the local CICS® region, is obsolete and is removed
  - **REQUESTMODEL**
    - The REQUESTMODEL resource, used for defining how an Internet Inter-ORB Protocol (IIOP) inbound request is mapped to the CICS transaction that is to be initiated, is obsolete, and is removed
  - **JVMPROFILE in PROGRAM resource**
    - The JVMPROFILE attribute in PROGRAM definitions is obsolete and is removed from CICS as part of the removal of support for JVM pool infrastructure. The attribute is supported for CSD compatibility for earlier releases of CICS where it is still valid.
- **Changed Resource Definitions or Attributes**
  - **TCPIPService resource definition: changed AUTHENTICATE attribute**
    - The value ASSERTED for the AUTHENTICATE attribute, used for authentication when an IIOP client communicates with the target server through an intermediate server, is now obsolete. The value is supported for CSD compatibility for earlier releases of CICS where it is still valid.
  - **TCPIPService resource definition: changed TYPE attribute**
    - The value IIOP for the TYPE attribute is now obsolete. The value is supported for CSD compatibility for earlier releases of CICS where it is still valid.





# Notes

- The Corbaserver, DJAR and Requestmodel resources are obsolete.
- With the removal of pooled JVM support the JVMPROFILE parm on program defns is obsolete.
- Attributes relating to IIOF on the TCPIPSERVICE definition are obsolete.



# External Changes...

- Macro Control Tables
  - Reassemble all tables against the CICS TS V5.1 libraries
  - CICS initialization will fail if you try and load an old version of DFHCNV (data conversion tables)



# Notes

- Macro Tables
- When upgrading to CICSTS V5.1 reassemble all CICS control tables using the CICS TS V5.1 macro libraries, even if the macro externals have no changes. You must also reassemble any DFHCNV data conversion tables that you use, because CICS initialization fails if you try to load DFHCNV tables assembled using macros from an earlier release.

# External Changes...

## ■ Obsolete SPI commands

- CREATE CORBASERVER
- CREATE DJAR
- CREATE REQUESTMODEL
- DISCARD CORBASERVER
- DISCARD DJAR
- DISCARD REQUESTMODEL
- INQUIRE BEAN
- INQUIRE CLASSCACHE
- INQUIRE CORBASERVER
- INQUIRE DJAR
- INQUIRE JVM
- INQUIRE JVMPOOL
- INQUIRE JVMPROFILE
- INQUIRE REQUESTMODEL
- INQUIRE WORKREQUEST
- INQUIRE ASSOCIATION
- PERFORM CLASSCACHE
- PERFORM CORBASERVER
- PERFORM DJAR
- PERFORM JVMPOOL
- SET CLASSCACHE
- SET CORBASERVER
- SET JVMPOOL
- SET WORKREQUEST

# Notes

- If you use these obsolete system programming commands in new or existing CICS application programs, CICS returns responses as follows:
- If you translate a program that includes any of the commands, the CICS translator returns a warning.
- If you run a program that includes any of the DISCARD, INQUIRE, or SET commands, CICS returns a NOTFND response.
- If you run a program that includes any of the CREATE commands, CICS returns an INVREQ response with a RESP2 value of 687.
- For any commands that support a browse option, a NORMAL condition is returned for the START browse and END browse operations, and the END condition is returned for the NEXT browse operation.

# External Changes...

- Obsolete SPI options
  - COLLECT STATISTICS
    - The BEAN, CORBASERVER, JVMPOOL, JVMPROFILE, and REQUESTMODEL options are obsolete
  - CSD INSTALL
    - The CORBASERVER, DJAR, and REQUESTMODEL options are obsolete
  - INQUIRE DISPATCHER
    - The ACTJVMTCBS option and the MAXJVMTCBS option are obsolete
  - PERFORM STATISTICS RECORD
    - The BEAN, CORBASERVER, JVMPOOL, JVMPROFILE, and REQUESTMODEL options are obsolete.
  - SET DISPATCHER
    - The MAXOPENTCBS, MAXJVMTCBS, and MAXXPTCBS options are obsolete.
  - SET SYSTEM
    - The MAXOPENTCBS option is obsolete.



# Notes

## COLLECT STATISTICS

The BEAN, CORBASERVER, JVMPOOL, JVMPROFILE, and REQUESTMODEL options are obsolete. If you run a program that includes any of these options, CICS returns a NOTFND response with a RESP2 value of 0.

- CSD INSTALL
- The CORBASERVER, DJAR, and REQUESTMODEL options are obsolete. If you run a program that includes any of these options for the CSD INSTALL command, CICS returns an INVREQ response with a RESP2 value of 687.
- INQUIRE DISPATCHER
- The ACTJVMTCBS option and the MAXJVMTCBS option are obsolete. ACTJVMTCBS was used to inquire on the number of J8 and J9 mode TCBs currently allocated to user tasks. MAXJVMTCBS was used to inquire on the maximum number of J8 and J9 mode TCBs allowed in the JVM pool.
- PERFORM STATISTICS RECORD
- The BEAN, CORBASERVER, JVMPOOL, JVMPROFILE, and REQUESTMODEL options are obsolete. If you run a program that includes any of these options, CICS returns a normal response but does not record any statistics for those resource types.
- SET DISPATCHER
- The MAXOPENTCBS, MAXJVMTCBS, and MAXXPTCBS options are obsolete. MAXJVMTCBS was used to change the maximum number of J8 and J9 mode open TCBs allowed in the JVM pool, which no longer exists. MAXOPENTCBS and MAXXPTCBS were used to change the maximum numbers of L8 and L9 mode open TCBs, and X8 and X9 mode open TCBs, respectively. The limits for these types of open TCB are now set by CICS automatically based on the MXT value for the CICS region.
- SET SYSTEM
- The MAXOPENTCBS option is obsolete. MAXOPENTCBS was used to change the maximum numbers of L8 and L9 mode open TCBs. The limit for these types of open TCB is now set by CICS automatically based on the MXT value for the CICS region.

# External Changes...

- New SPI options
  - ENABLE EXIT
    - A new options GALLOCATION and REQUIRED are added
  - INQUIRE ASSOCIATION
    - New options ACAPPLNAME, ACMAJORVER, ACMICROVER, ACMINORVER.ACOPERNAME, ACPLATNAME are added
  - INQUIRE BUNDLE
    - New options BUNDLEID, MGMTPART, MAJORVERSION, MICROVERSION, MINORVERSION are added
  - INQUIRE BUNDLEPART
    - The PARTCLASS option returns a new value ENTRYPOINTew value REQUIRED is added to the CONCURRENCY option
  - INQUIRE CAPTURESPEC
    - The PRIMPREDTYPE option returns a new value MESSAGEID
  - INQUIRE DISPATCHER
    - The MAXOPENTCBS and MAXXPTCBS options on the INQUIRE DISPATCHER command are still available, but the values that they return now represent limits set automatically by CICS based on the maximum number of tasks specified for the CICS region
  - INQUIRE DSNAME
    - New option LOGREPSTATUS to support replication logging.

# Notes

- A new option, GALLOCATION, is added to the ENABLE PROGRAM command to choose the storage location for the global work area for global user exits and task related user exits.
- A new option REQUIRED, is added to the ENABLE PROGRAM command to control which TCB runs a task-related user exit.
- The INQUIRE ASSOCIATION command has new options to support application context data.
- The INQUIRE BUNDLE command has new options to support bundle ID and version information.
- On INQUIRE BUNDLEPART, the PARTCLASS option on the INQUIRE BUNDLEPART command has a new value: ENTRYPOINT - The resource is an entry point to an application.
- On INQUIRE CAPTURESPEC, the PRIMPREDTYPE option has a new value MESSAGEID - The primary predicate is a CICS or CPSM message id of form DFHxxnnnn or EYUxxnnnn.
- INQUIRE DISPATCHER
- The MAXOPENTCBS and MAXXPTCBS options on the INQUIRE DISPATCHER command are still available, but the values that they return now represent limits set automatically by CICS based on the maximum number of tasks specified for the CICS region.
- INQUIRE DSNAME
- The INQUIRE DSNAME command has a new option to support replication logging.



# External Changes...

- New SPI options
  - INQUIRE EVENTBINDING
    - New options EPADAPTERRES and EPADAPTERSET are added
  - INQUIRE EXITPROGRAM
    - A new value REQUIRED can be returned for CONCURRENTST
  - INQUIRE JVMSERVER
    - A new option PROFILEDIR has been added
  - INQUIRE PROGRAM
    - New options APPLICATION, APPLMAJORVER, APPLMINORVER, APPLMICROVER, ENTRYPOINT and OPERATION are added.
  - INQUIRE SYSTEM
    - New options ETDSASIZE, GCDSASIZE, GSDSASIZE, and GUDSASIZE are added
  - INQUIRE URIMAP
    - The USAGE option has a new value JVMSERVER
  - SET PROGRAM
    - A new option OPERATION has been added
  - SET STATISTICS
    - The default value for interval has decreased from 3hrs to 1hr
  - SET SYSTEM
    - The max value for MAXTASKS has increased to 2000 and the minimum to 10



# Notes

The INQUIRE EVENTBINDING command is changed to support multiple adapters.

- INQUIRE EXITPROGRAM: The CONCURRENTST option of the INQUIRE EXITPROGRAM command is extended to return a third CVDA, REQUIRED indicating the concurrency status of the global or task-related user exit program. This is the value of the CONCURRENCY attribute of the PROGRAM definition, or of any override specified by the latest ENABLE command for this program.
- The INQUIRE JVMSERVER command is changed to support the new option PROFILEDIR. It returns a 240-character data value of the directory on z/OS UNIX that contains the JVM profiles for CICS.
- INQUIRE PROGRAM
- The ENTRYPOINT option of the INQUIRE PROGRAM command is changed to support non-Language Environment AMODE(64) assembler programs. The INQUIRE PROGRAM command is changed to support the new APPLICATION, APPLMAJORVER, APPLMINORVER, APPLMICROVER, OPERATION and PROGRAM options, which tell CICS that the PROGRAM resource is an entry point for an application.
- The INQUIRE SYSTEM has new options to return the size of the new 64bit DSAs. The MAXOPENTCBS option on the INQUIRE SYSTEM command is still available, but the value that it returns now represents a limit set automatically by CICS based on the maximum number of tasks specified for the CICS region.
- The USAGE option on the INQUIRE URIMAP command has a new value: JVMSERVER
- A URIMAP for a JVM server. This type of URIMAP resource maps an incoming request for a Java web application to run under a CICS transaction that has appropriate security.
- The SET PROGRAM command has a new option OPERATION. OPERATION(64-character data-value) Specifies the name of the application operation for which this program is to be defined as an application entry point.
- The default value of the INTERVAL option on the SET STATISTICS command is decreased from 3 hours to 1 hour.
- The maximum value of the MAXTASKS option of the SET SYSTEM command is increased from 999 to 2000, and the minimum value is increased to 10.

# External Changes...

- New SPI Commands
  - **PERFORM SSL REBUILD**
    - Refresh the SSL environment and the cache of certificates for the CICS region
  - **INQUIRE EPADAPTERSET**
    - Retrieve information about a specified event processing adapter set
  - **INQUIRE EPADAPTINSET**
    - Retrieve the names of all EP adapters that are specified in an EP adapter set or check whether or not a named EP adapter set contains a named EP adapter
  - **SET EPADAPTERSET**
    - Set the status of a specified EP adapter set to enabled or disabled



# Notes

CICS TS 5.1 includes some new SPI commands that you can use to control new system resources or to work in new ways with existing resources.



## External Changes...

- New CEMT Commands
  - **PERFORM SSL REBUILD**
    - Refresh the SSL environment and the cache of certificates for the CICS region
  - **INQUIRE EPADAPTERSET**
    - Retrieve information about an EP adapter set
  - **SET EPADAPTERSET**
    - Enable or disable an EP adapter set



# Notes

The same extensions to SPI commands are available via CEMT.



# External Changes...

- Changed CEMT Commands
  - **INQUIRE BUNDLE**
    - New options BUNDLEID, MAJORVERSION, MICROVERSION and MINORVERSION are added
  - **INQUIRE DSAS**
    - New options ETDSASIZE, GCDSASIZE, GSDSASIZE, and GUDSASIZE are added
  - **INQUIRE DISPATCHER**
    - The MAXOPENTCBS and MAXXPTCBS options on the INQUIRE DISPATCHER command are still available, but the values that they return now represent limits set automatically by CICS based on the maximum number of tasks specified for the CICS region
  - **INQUIRE DSNAME**
    - New option LOGREPSTATUS to support replication logging
  - **INQUIRE EVENTBINDING**
    - New options EPADAPTERRES and EPADAPTERSET are added



# Notes

- The slide lists CEMT commands that have new options or new values for options.



# External Changes...

- Changed CEMT Commands
  - INQUIRE JVMSERVER
    - A new option PROFILEDIR has been added
  - INQUIRE PROGRAM
    - New options APPLICATION, APPLMAJORVER, APPLMINORVER , APPLMICROVER, ENTRYPOINT and OPERATION are added
  - INQUIRE URIMAP
    - The USAGE option has a new value JVMSERVER
  - SET PROGRAM
    - A new option OPERATION has been added
  - SET STATISTICS
    - The default value for interval has decreased form 3hrs to 1hr
  - SET SYSTEM
    - The max value for MAXTASKS has increased to 2000 and the minimum to 10





# Notes

- The slide lists CEMT commands that have new options or new values for options.



## External Changes...

- OBSOLETE CEMT Commands
  - INQUIRE CLASSCACHE
  - INQUIRE JVM
  - INQUIRE JVMPOOL
  - PERFORM CLASSCACHE
  - PERFORM JVMPOOL
  - SET CLASSCACHE
  - SET JVMPOOL



# Notes

- CEMT commands relating to pooled JVM support have been withdrawn.



# External Changes...

- New CICS Supplied Category 2 Transactions
  - CKBC
    - Specify CKBC, or your own transaction based on CKBC, to use channels and containers with the CICS-WebSphere MQ DPL Bridge
    - CKBC runs program DFHMQBP3. This program passes and receives data using the DFHMQBR\_CHANNEL channel & DFHREQUEST and DFHRESPONSE containers
  - CJSA
    - It is the default transaction to start CICS tasks that run new threads in the JVM server for a Java application. You can override it using a URIMAP resource
  - CJSD
    - It handles general configuration errors in the Liberty profile server where the task could not be attached
  - CJST
    - It handles a specific configuration error in the Liberty profile server where the application is unavailable
  - CJSU
    - It handles authorization failures in the Liberty profile server.



# Notes



- CKBC was introduced in CICS Transaction Server for z/OS, Version 5 Release 1. Specify CKBC, or your own transaction based on CKBC, to use channels and containers with the CICS-WebSphere MQ DPL Bridge.
- CKBC runs program DFHMQBP3. This program passes and receives data using the DFHMQBR\_CHANNEL channel and the DFHREQUEST and DFHRESPONSE containers.
- To continue to pass and receive data using a COMMAREA, allow the transaction code to default to CKBP, or specify CKBP (or a transaction code modeled on CKBP), to run program DFHMQBP0.
- CKBC is a RACF category 2 transaction.
- CJSA was introduced in CICS Transaction Server for z/OS, Version 5 Release 1 for JVM servers. It is the default transaction to start CICS tasks that run new threads in the JVM server for a Java application. You can override it using a URIMAP resource.
- CJSA is defined in the CICS-supplied resource definition group DFHJAVA. The JVM server has a listener that runs as a long-running task. The listener runs the CJSA transaction to create CICS tasks when an application requests a new thread. These threads can use JCICS to access CICS services.
- CJSD was introduced in CICS Transaction Server for z/OS, Version 5 Release 1 for the Liberty profile server. It handles general configuration errors in the Liberty profile server where the task could not be attached.
- CJSD is defined in the supplied resource definition group DFHJAVA. The Liberty profile server accepts application requests through TCP/IP sockets. By default, all requests run under the CJSA transaction, but optionally you can switch the transaction ID using a URI map. If the transaction is not defined or an unexpected failure occurs, the CJSD transaction runs and returns a HTTP 500 error message to the application user.
- CJST was introduced in CICS Transaction Server for z/OS, Version 5 Release 1 for the Liberty profile server. It handles a specific configuration error in the Liberty profile server where the application is unavailable.
- CJST is defined in the supplied resource definition group DFHJAVA. The Liberty profile server accepts application requests through TCP/IP sockets. By default, all requests run under the CJSA transaction, but optionally you can switch the transaction ID using a URI map. If the transaction is disabled, the application is unavailable. The CJST transaction runs and returns a HTTP 503 error message to the application user.
- CJSU was introduced in CICS Transaction Server for z/OS, Version 5 Release 1 for the Liberty profile server. It handles authorization failures in the Liberty profile server.
- CJSU is defined in the supplied resource definition group DFHJAVA. The Liberty profile server accepts application requests through TCP/IP sockets. By default, all requests run under the CJSA transaction, but optionally you can switch the transaction ID using a URI map. If the user is not authorized to run the transaction to access the application, the CJSU transaction runs and returns a HTTP 403 error message to the application user.



# External Changes...

- Changed CICS supplied Transactions
  - CETR
    - The CETR transaction now includes controls for setting the MP domain standard and special trace levels
    - The Pooled JVMs Trace Options screen has been removed
  
- Obsolete CICS supplied Transactions
  - CIRP
    - Request processor transaction for CorbaServers
  - CIRR
    - Request receiver transaction for CorbaServers
  - CJGC
    - CICS JVM garbage collection transaction
  - CJPI
    - Started JVMs following a PERFORM JVMPOOL command
  - CREA
    - Generated REQUESTMODEL definitions dynamically or saved them in the CSD
  - CREC
    - Generated REQUESTMODEL definitions but could not update the CSD



# Notes

- Some CICS-supplied transactions are new, or have changed to support new functions.





# External Changes...

- Global User Exits
  - It is ***HIGHLY recommended*** that **ALL** global user exits be analyzed to ensure that they are **THREADSAFE** and that their PROGRAM definitions changed to specify CONCURRENCY(THREADSAFE)
  - All exits that use XPI DFHKEDSX START\_PURGE\_PROTECTION & STOP\_PURGE\_PROTECTION calls **MUST** be reassembled
  - In the DFHLDLDX loader functions of the XPI, the size of the tokens that are used for the PROGRAM\_TOKEN and NEW\_PROGRAM\_TOKEN options has increased from 4 bytes to 8 bytes
    - Programs need to be changed and re-assembled
  - For other XPI check information in CICS Infocenter



# Notes

- The CICS global user exit programming interface is product-sensitive, and depends on the facilities that are set up in your CICS system. It is advisable to reassemble global user exit programs for each CICS release, because changes to CICS internals might affect structures used by the CICS global user exit programming interface, even if there are no changes to the externals of the programming interface.
- In CICS TS for z/OS, Version 5.1, there are changes to the parameter list structure for functions on the KEDS gate. If you have global user exit programs that use the kernel domain XPI functions, which are the DFHKEDSX calls START\_PURGE\_PROTECTION and STOP\_PURGE\_PROTECTION, then you must reassemble those exit programs.
- Check the CICS Infocenter. Section is entitled:
- Changes to global user exits, task-related user exits, and the exit programming interface

## External Changes...

- Global User Exits
  - Changed DFHUEPAR parameter lists
    - Equates UEPTJ8, UEPTJ9 and UEPTJM have been removed because these TCB types no longer exist
  - Choice of Global Work AREA Location
    - The GWA can be moved into 31bit storage by specifying `GALLOCATION(DFHVALUE(LOC31))`. The default is still 24bit storage
  - Increase to UEPXSTOR storage
    - The LIFO storage that CICS provides for a global user exit program to use when calling the XPI is increased from 320 bytes to 1024 bytes. The global user exit program can access this storage using parameter UEPXSTOR of the DFHUEPAR parameter list.
  - Backout exit programs enabled with TBEXITS system initialization parameter
    - The four byte GWA is now in 31bit storage

# Notes

- The TBEXITS system initialization parameter enables specified global user exit programs as backout exit programs. The backout exit programs are used during emergency restart backout for user log record recovery and file control recovery. Before CICS TS for z/OS, Version 5.1, these global user exit programs were enabled with a global work area of 4 bytes in 24-bit storage (below the 16 MB line). In CICS TS for z/OS, Version 5.1, these global user exit programs are enabled with a global work area of 4 bytes in 31-bit storage (above 16 MB but below 2 GB).
- You can use the TBEXITS system initialization parameter to specify programs to be invoked at the following global user exit points:
  - User log record recovery program exits: XRCINIT and XRCINPT
  - File control backout failure exit: XFCBFAIL
  - File control backout exit: XFCBOUT
  - File control backout override exit: XFCBOVER
  - File control logical delete exit: XFCLDEL



# External Changes...

- Global User Exits
  - Program control program exit: XPCFTCH
    - This exit now indicates the addressing mode of the program that has been loaded. The UEPPCDS parameter now includes the following DFHPCUE fields:
      - *PCUE\_AMOD* The addressing mode of the program is AMODE(31). This field is provided for compatibility with existing exit programs
      - *PCUE\_AMOD\_31* The addressing mode of the program is AMODE(31). Use this field in preference to PCUE\_AMOD
      - *PCUE\_AMOD\_64* The addressing mode of the program is AMODE(64)
  - Resource management installation and discard exit: XRSINDI
    - A new parameter is added to support the EPADAPTERSET resource and the EPADAPTERSET resource signature parameter.
      - *UEIDEPAS* An EPADAPTERSET resource.
    - The obsolete UEIDBEAN enterprise bean parameter is removed
  - System recovery program exit: XSRAB
    - Two new parameters SRP\_CICS\_PSW16 & SRP\_SYSTEM\_PSW16 added to support 128 bit PSW
  - Transient data exits: XTDEREQ, XTDEREQC, XTDREQ, XTDIN, and XTDOUT
    - Make exit programs threadsafe to avoid excessive TCB switching



# Notes

- Exit XSRAB is invoked when the system recovery program (DFHSRP) finds a match in the system recovery table (SRT) for an operating system abend code. The error data structure, SRP\_ERROR\_DATA, that is indicated by the UEPERROR parameter now includes the following SRP\_CICS\_ERROR\_DATA field:
  - SRP\_CICS\_PSW16
    - 16-character field that contains the 128-bit PSW
  - The UEPERROR parameter also includes the following SRP\_SYSTEM\_ERROR\_DATA field:
    - SRP\_SYSTEM\_PSW16
      - 16-character field that contains the 128-bit PSW
- The CICS transient data facility is now threadsafe, so CICS can process transient data requests on an open TCB. Transient data requests are also threadsafe when you function ship them to a remote region over an IPIC connection. To optimize TCB switching and gain the performance benefits of the open transaction environment, programs that run at XTDEREQ, XTDEREQC, XTDREQ, XTDIN, and XTDOU must be coded to threadsafe standards and defined to CICS as threadsafe.
- The XTDEREQ exit is invoked before CICS processes a transient data API request, and the XTDEREQC exit is invoked after processing a transient data API request. The XTDREQ exit intercepts a transient data request before request analysis. The XTDOU and XTDIN exits are invoked before and after data is exchanged with QSAM or VSAM.

# External Changes...

- Task Related User Exits...
  - Choice of Global Work AREA Location
    - The GWA can be moved into 31 bit storage by specifying GALLOCATION(DFHVALUE(LOC31)). The default is still 24 bit storage
  - New options for ENABLE PROGRAM
    - REQUIRED, OPENAPI TRUEs always run on an L8 (equivalent to OPENAPI in previous releases)
    - REQUIRED, CICSAPI TRUEs can run on any key8 open TCB: L8, T8 or X8
  - New TRUE invocation
    - TRUEs can express interest in switch\_application environment events
    - Allows TRUE to remove its state from a TCB if a switch is to occur
    - Only happens for REQUIRED, CICSAPI TRUEs
    - For more Information see the CICS Infocenter

## Notes

- A new option, **REQUIRED**, is added to the **ENABLE PROGRAM** command. You can use this option to specify that a task-related user exit will run on an open TCB. If **OPENAPI** is specified, an L8 TCB will be used. If **OPENAPI** is not specified, any eligible key-8 open TCB can be used: L8, T8, or X8.
- The **CONCURRENTST** option of the **INQUIRE EXITPROGRAM** command now returns a new CVDA, **REQUIRED**, to indicate that the task-related user exit will always run on an open TCB. When a task-related user exit is enabled **REQUIRED** and **OPENAPI**, it is treated the same as if it were enabled **THREADSAFE** and **OPENAPI**. For compatibility, an **INQUIRE EXITPROGRAM** for either combination will always return **THREADSAFE, OPENAPI**. For a task-related user exit enabled **REQUIRED** and **CICSAPI**, **INQUIRE EXITPROGRAM** will return **REQUIRED, CICSAPI**.
- During the life of the task, the type of TCB can change. This is called a **switch\_application\_environment** event. A task-related user exit can express an interest in a **switch\_application\_environment** event that happens during the lifetime of a task, so that it can remove any affinity it has to the open TCB currently being used. This is relevant to TRUEs that are enabled as **REQUIRED, CICSAPI**, which means they can be called on an X8, L8, or T8 TCB.



# External Changes...

- User Replaceable Modules...
  - Obsolete User Replaceable Modules
    - DFHEJDNX
      - *The distinguished name user-replaceable program is obsolete because EJB support is removed.*
    - DFHEJEP
      - *The EJB event program is obsolete because EJB support is removed.*
    - DFHJVMAT
      - *The program to override JVM profile options is obsolete because support for pooled JVMs is removed.*
    - DFHJVMRO
      - *The program to modify the enclave for pooled JVMs is obsolete because support for pooled JVMs is removed.*
    - DFHXOPUS
      - *The IOP security exit program is obsolete because IOP cannot be specified on a TCPIP SERVICE resource.*





# Notes

- User replaceable modules concerned with EJBs, IIOP and pooled JVMs have been removed.



## External Changes...

- User Replaceable Modules...
  - Changed User Replaceable Modules
    - DFHXCURM - External interface program
      - *A new parameter, URMXCFG, is used to dynamically set the value of the XCFGROUP parameter in the DFHXCOPT table. The value is used by DFHXCURM for an EXCI allocate\_pipe request*
  - New User Replaceable module
    - New sample user-replaceable program for IPCONN autoinstall
      - *Assembler sample DFH\$ISAI*
      - *COBOL sample DFH0ISAI.*

# Notes

- The supplied source of this new user-replaceable program is a sample to illustrate a technique of customizing autoinstall of an IPCONN, such that the IPCONN name and APPLID are generated according to a template IPCONN that is previously installed.
- The source of the additional IPCONN autoinstall user replaceable program is supplied in the SDFHSAMP library. The code is supplied in assembler as module DFH\$ISAI and COBOL as module DFH0ISAI. The executable load modules are supplied in the CICSTS SDFHLOAD library.
- When the user-replaceable program is deployed, all IPIC install requests are based on a template IPCONN that is taken from the network ID of the partner (for CICS Transaction Gateway clients, this is the APPLID qualifier). Connection requests are accepted only if the APPLID of the partner matches the APPLID value specified in the template IPCONN.

# External Changes...

- Monitoring
  - Record size increases to 3260 bytes
  - MCT default changed from RMI=NO to RMI=YES
  - New monitoring data
    - CEC Machine Type and Model ID
    - Current active task count and maxtask setting
    - Extensions to allow better WAIT analysis
      - *MRO/ISC Allocate Waits*
      - *IPIC Allocate Waits*
      - *RO TCB and SO TCB Mode Delays*
      - *Intrapartition and Extrapartition TD Lock Waits*
      - *File Control Exclusive Control Waits*
      - *VSAM File String Waits*
      - *Total CPU time on standard CP*
    - Total Offload CPU time on standard CP
    - SSL Cipher code
    - Application context
    - Policy exceeded count
    - Storage Waits in GCDSA, GUDSA, and GSDSA



# Notes

- The length of a standard performance class monitoring record, as output to SMF, has increased to 3260 bytes. The length does not take into account any user data that you add or any system-defined data fields that you exclude by using a monitoring control table (MCT).
- The new CECMCHTP and CECMDLID fields in the DFHTASK performance class group for a transaction show the CEC machine type and CEC model number for the physical hardware environment where the CICS region is running. CEC (central electronics complex) is a commonly used synonym for CPC (central processing complex), which refers to a collection of physical hardware including main storage, one or more central processors, timers, and channels.
- You can use this information with the IBM Large Systems Performance Reference (LSPR) ratios to make an accurate assessment of CICS performance and relative processor capacity, particularly when considering upgrades to your z/OS hardware.
- The new MAXTASKS field in the DFHTASK performance class group for a transaction records the current setting for the maximum number of tasks for the CICS region. The CURTASKS field records the current number of active user transactions in the system at the time the user task was attached. This data helps with assessing the relationship between the task load during the life of a transaction, and the performance of the transaction.
- The new CPUTONCP and OFFLCPUT fields in the DFHTASK performance class group for a transaction can be used to calculate the processor time that a task spends on a zIIP or zAAP specialty processor, and also show you the processor time that the task could have spent on a specialty processor.
- A single cipher is negotiated during an SSL handshake between a server and a client. That cipher is used for all subsequent traffic on the SSL connection. CICS now displays the code for the cipher suite in the performance data field SOCIPHER in the DFHSOCK group. You can use this information to identify any cipher suites that are offered by the CICS region but are not being selected for SSL connections. You can also identify any less efficient or less secure cipher suites that are being selected for SSL connections but that you would prefer to eliminate.
- The default value for the MCT Resource Manager Interface (RMI) parameter has changed from RMI=NO to RMI=YES. With the new setting, additional monitoring performance data is collected by default for the resource managers used by your transactions.

# External Changes...

- Statistics
  - Storage Manager Statistics
    - New GxDSAs for 64-bit storage
      - *DSA statistics*
      - *Domain Subpool statistics*
      - *Task Subpool statistics*
  - Loader Global Statistics
    - New statistics on RO TCB program load requests and load time
  - Dispatcher Global Statistics
    - TCB Pools and TCB Modes
      - *JVM TCB Pool and J8/J9 TCB Modes Obsolete*
  - URIMAP Resource Statistics
    - Usage → JVMSERVER
  - Statistics Data Interval Collection Option
    - Default changed from STATINT=030000 to 010000 (hhmmss)
      - *Statistics Recording option STATRCD=NO|YES – default unchanged*
    - More timely statistics data collection – peak hour analysis



# Notes

- CICS statistics are enhanced to provide more information that relates to the load, capacity, and performance of the system. This information can aid decisions about vertical and horizontal scalability.





# External Changes...

- Sample Programs
  - DFH\$DB2, JDBC sample group
    - The JDBC Datasource samples removed
  - DFH\$DCTD, DFH\$DCTR, and DFH\$DCTS, DCT samples
    - Removed because the DFHDCT macro has been removed
  - DFH\$EJB and DFH\$EJB2 samples
    - The EJB Hello World & EJB Bank account sample
  - DFH\$IOP
    - The IOP Banking sample is removed
  - DFH\$PCTA, XPCTA global user exit program sample
    - Now updated to include the ETDSA, GCDSA, and GUDSA
  - DFH\$WLP and DFHWLP JVM server samples
    - Sample JVMSERVER profile to run Liberty
  - FILEA sample application programs for assembler language
    - The sample programs for assembler language are changed to AMODE(64) and use relative addressing



# Notes

- DFH\$WLP is a sample JVMSERVER resource definition that is in a group called DFH\$WLP. It points to a sample JVM profile called DFHWLP that configures a JVM server to use the WebSphere® Application Server Liberty profile.
- FILEA sample application programs for assembler language
- The following sample application programs for assembler language are changed to AMODE(64) and use relative addressing:
  - DFH\$AALL
  - DFH\$ABRW
  - DFH\$ACOM
  - DFH\$AMNU
  - DFH\$AREN
- The following sample application program for assembly language is changed to use relative addressing, but is AMODE(31) because it demonstrates the use of the HANDLE CONDITION LABEL command:
  - DFH\$AREP

# External Changes...

- Application Programming Interface changes
  - **ASSIGN**
    - New ASRAPSW16 & ASRAREGS64 to support Amode 64 assembler applications
  - **LOAD PROGRAM**
    - The ENTRY option is changed to support non-Language Environment (LE) AMODE(64) assembler programs
      - *AMODE(24): bit 0 is 0 and bit 31 is 0*
      - *AMODE(31): bit 0 is 1 and bit 31 is 0*
      - *AMODE(64): bit 0 is 0 and bit 31 is 1*
  - **QUERY SECURITY**
    - New resource type of EPADAPTERSET
  - **START**
    - Supports identity propagation
  - **VERIFY**
    - SIT parm SECVFYFREQ=USRDELAY enforces a full verification request at least once a day

# Notes

- Two new options are provided for the ASSIGN command to support non-Language Environment (LE) AMODE(64) assembler programs:
  - ASRAPSW16(data-area)
    - Returns a 16-byte data area that contains the 128-bit program status word (PSW) at the point when the latest abend with a code of AICA, ASRA, ASRB, ASRD, or ASRE occurred.
    - The field contains binary zeros if no AICA, ASRA, ASRB, ASRD, or ASRE abend occurred during the execution of the issuing transaction, or if the abend originally occurred in a remote DPL server program.
  - ASRAREGS64(data-area)
    - Returns the contents of the 64-bit general registers 0 - 15 at the point when the latest AICA, ASRA, ASRB, ASRD, or ASRE abend occurred.
- The EXEC CICS START and EXEC CICS START CHANNEL commands are enhanced to support identity propagation. If an ICRX is available and none of the parameters USERID, TERMID or RTERMID are specified, the ICRX is propagated to the new task.
- The EXEC CICS SIGNON command uses the RACROUTE REQUEST=VERIFY macro to make a full verification request to the external security manager. However, the EXEC CICS VERIFY PASSWORD and EXEC CICS VERIFY PHRASE commands normally use the RACROUTE REQUEST=EXTRACT macro to verify a user's password. If password verification fails, CICS then uses the RACROUTE REQUEST=VERIFYX macro to make a full verification request.
- The RACROUTE REQUEST=EXTRACT macro does not make RACF record the login as the last access for the user ID, or write user statistics for the user ID. User IDs that are only used with login processes involving password verification can therefore appear to be unused, and could be revoked.
- If you specify the system initialization parameter SECVFYFREQ=USRDELAY for the CICS region, CICS enforces a full verification request at least once a day for each user ID that is used to log on to the CICS region. The full verification request using the RACROUTE REQUEST=VERIFYX macro makes RACF record the date and time of last access for the user ID, and write user statistics.



# Upgrade Process

- Operating System Setup
  - CICS uses z/OS conversion services
    - Conversion facility must be enabled
    - Documented in “z/OS Support for Unicode Using Conversion Services”
  - SDFHLINK modules are downward compatible
    - e.g. SVC, DFHIRP
    - New DFHCSVCU utility to install CICS SVC without z/OS IPL
      - *Considerations for DFHIRP*
  - SEYULINK modules are not downward compatible
  - MEMLIMIT needs to be set equal to or greater than 6GB



# Notes

- For Unicode conversion support, you must enable the z/OS conversion services and install a conversion image which specifies the conversions that you want CICS to perform. Refer to the instructions in the z/OS Support for Unicode: Using Conversion Services manual SA22-7649 to find out the steps needed to set up and configure conversions supported through the operating system services.
- Unless otherwise stated, the CICS Transaction Server for z/OS, V5.1 levels of the modules in SDFHLINK are compatible with earlier releases of CICS. The CICSplex SM modules in SEYULINK are not compatible with earlier releases. CICSplex SM modules in SEYULINK are release specific. If you plan to run multiple releases of CICSplex SM on the same MVS image, you must have the equivalent modules specific to the releases you are running.

# Upgrade Process...

- Installation Process
  - Default installation process
    - Common IBM install procedures
    - SMP/E RECEIVE, APPLY, ACCEPT commands
    - Described in the CICS Program Directory
  - DFHISTAR process
    - CICS generated installation job stream
    - Described in the CICS Installation Guide

# Notes

- This release of CICS Transaction Server is installed using the SMP/E RECEIVE, APPLY, and ACCEPT commands. The SMP/E dialogs may be used to accomplish the SMP/E installation steps. The process is described in the CICS TS Program Directory. It is in line with IBM Corporate Standards, and may be familiar to those who have installed other z/OS products.
- The traditional method, DFHISTAR, of installing CICS Transaction Server is described in the CICS Installation Guide

# Upgrade Process...

- CICS Local and Global Catalog
  - Define new Local and Global catalogs
  - Initialize the catalogs using CICS TS V5.1 utilities
  - Perform a START=INITIAL
  - CICS will fail startup if back level GCD or LCD is used
    - DFHRM0100 applid GLOBAL CATALOG DATA SET IS NOT INITIALIZED FOR THIS RELEASE OF CICS
    - DFHCC0107 applid LOCAL CATALOG DATA SET IS NOT INITIALIZED FOR THIS RELEASE OF CICS



## Notes

- Define and initialize new local and global catalogs, following the instructions in Setting up the catalog data sets . When you initialize the catalogs, make sure that you use the CICS TS V5.1 versions of the DFHRMUTL and DFHCCUTL utility programs and the sample jobs.
- When you start the CICS region for the first time after upgrading, make sure that it is an initial start with the START=INITIAL parameter.
- CICS now protects against the wrong level catalogs being used and fails startup with new messages.

# Upgrade Process...

- CICS System Definition (CSD)
  - Define New CSD
  - REPRO existing CSD to new dataset
  - Run DFHCSDUP UPGRADE
    - Use DFHCSDUP SCAN command to check for user changes
  - Sharing the CSD
    - CICS TS V5.1 CSD can be shared with prior releases
      - *DFHCOMPF (42)*
      - *DFHCOMPE (41)*
      - *DFHCOMPD (32)*
      - *DFHCOMPC (31)*

# Notes

- Run the DFHCSDUP utility program, specifying the UPGRADE command, to upgrade the CICS-supplied definitions in your CSD to the latest CICS TS level. You can create a new CSD using the DFHCSDUP INITIALIZE command.
- A CICS TS V5.1 CSD can be shared with lower level CICS TS releases

# Upgrade Process...

- CICSplex Systems Manager
  - CICSplex upgrade similar to previous releases
    - Maintenance point CMAS must be upgraded first
  - CMAS and MAS agent code must all be at V5.1 level
  - WUI Server and its connected CMAS must be at V5.1 level



# Notes

- You must migrate your CICSplex SM CMAS to CICS TS V5.1 at the same time as you migrate the CICS system on which it runs. This is because a CICSplex SM CMAS will run only in a CICS system at the same release level.
- Both the Web User Interface server and the CMAS that it connects to must be at the highest level of CICSplex SM within the CICSplex. This means that both must be at the same level as the maintenance point CMAS.
- Before you migrate a Web User Interface server, you must migrate the CMAS that it connects to. You must migrate the Web User Interface server before you migrate any other MASs. If the CMAS that the Web User Interface server connects to is not the maintenance point CMAS, you must migrate the maintenance point CMAS at the same time.
- As the CICS system that acts as your Web User Interface server is a local MAS, all the considerations that apply to a local MAS also apply to a Web User Interface server.

# Stabilization of Support

- CICSPlex SM Web User Interface (WUI)
  - The CICSPlex SM Web User Interface (WUI) for CICS TS is stabilized. Minor additions to existing views will continue. The CICSPlex SM WUI will not be withdrawn during the lifetime of CICS TS V5.
  - The CICSPlex SM address space (CMAS) and WUI server components continue to provide strategic support for the CICS Explorer V5.1 and form the basis of the modern CICS user experience. CICSPlex upgrade is similar to previous releases
- Extended Recovery Facility (XRF)
  - Extended Recovery Facility (XRF) is deprecated in CICS TS V5.1. Alternative technologies are available that provide more flexible high-availability solutions for modern workloads, including the z/OS Automatic Restart Manager (ARM), CICS data sharing and use of the cross-system coupling facility, and VTAM persistent sessions.

# Notes

- The slide list those CICS functions that are stabilized





# Discontinued functions

- CICS Message Editing Utility (DFHMEU)
  - The CICS Message Editing Utility (DFHMEU) is removed from CICS TS V5.1 and later
- Enterprise Java Beans
  - CICS TS V5.1 discontinues support for both session beans using Enterprise Java Beans (EJB), and the Java pool and its CORBA infrastructure
- CCI Connector for CICS TS
  - The CCI Connector for CICS TS is a deprecated Java interface that is no longer available in CICS TS V5.1
- CICS TS Feature Pack for Dynamic Scripting
  - CICS TS Feature Pack for Dynamic Scripting V1.0 runs on CICS TS V4.1 only
  - CICS TS Feature Pack for Dynamic Scripting V1.1 runs on CICS TS V4.2 only

No other versions of CICS TS are supported by this Feature Pack



# Notes

- The slide list those CICS functions not supported in CICS TS V5.1

# CICS Information Center

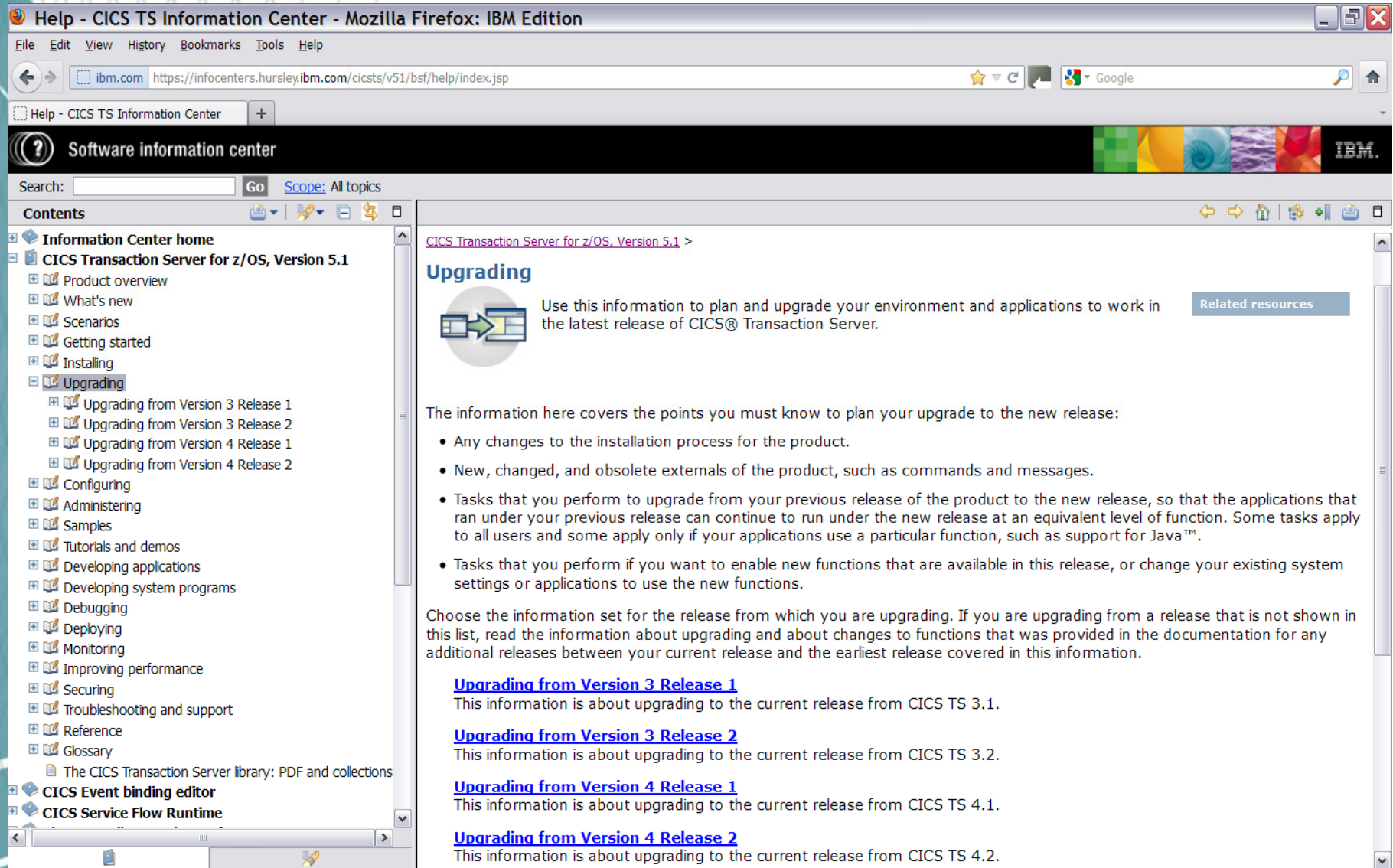

Help - CICS TS Information Center - Mozilla Firefox: IBM Edition

File Edit View History Bookmarks Tools Help

ibm.com https://infocenters.hursley.ibm.com/cicsts/v51/bsf/help/index.jsp

Help - CICS TS Information Center

Software information center

Search:  Go Scope: All topics

Contents

- Information Center home
- CICS Transaction Server for z/OS, Version 5.1
  - Product overview
  - What's new
  - Scenarios
  - Getting started
  - Installing
  - Upgrading
    - Upgrading from Version 3 Release 1
    - Upgrading from Version 3 Release 2
    - Upgrading from Version 4 Release 1
    - Upgrading from Version 4 Release 2
  - Configuring
  - Administering
  - Samples
  - Tutorials and demos
  - Developing applications
  - Developing system programs
  - Debugging
  - Deploying
  - Monitoring
  - Improving performance
  - Securing
  - Troubleshooting and support
  - Reference
  - Glossary
  - The CICS Transaction Server library: PDF and collections
- CICS Event binding editor
- CICS Service Flow Runtime

CICS Transaction Server for z/OS, Version 5.1 >

## Upgrading

Use this information to plan and upgrade your environment and applications to work in the latest release of CICS® Transaction Server.

[Related resources](#)

The information here covers the points you must know to plan your upgrade to the new release:

- Any changes to the installation process for the product.
- New, changed, and obsolete external of the product, such as commands and messages.
- Tasks that you perform to upgrade from your previous release of the product to the new release, so that the applications that ran under your previous release can continue to run under the new release at an equivalent level of function. Some tasks apply to all users and some apply only if your applications use a particular function, such as support for Java™.
- Tasks that you perform if you want to enable new functions that are available in this release, or change your existing system settings or applications to use the new functions.

Choose the information set for the release from which you are upgrading. If you are upgrading from a release that is not shown in this list, read the information about upgrading and about changes to functions that was provided in the documentation for any additional releases between your current release and the earliest release covered in this information.

[Upgrading from Version 3 Release 1](#)  
This information is about upgrading to the current release from CICS TS 3.1.

[Upgrading from Version 3 Release 2](#)  
This information is about upgrading to the current release from CICS TS 3.2.

[Upgrading from Version 4 Release 1](#)  
This information is about upgrading to the current release from CICS TS 4.1.

[Upgrading from Version 4 Release 2](#)  
This information is about upgrading to the current release from CICS TS 4.2.

# CICS Interdependency Analyzer

- Upgrade Analysis
  - Can help identify changes related to CICS upgrades
  - Query results can help target testing

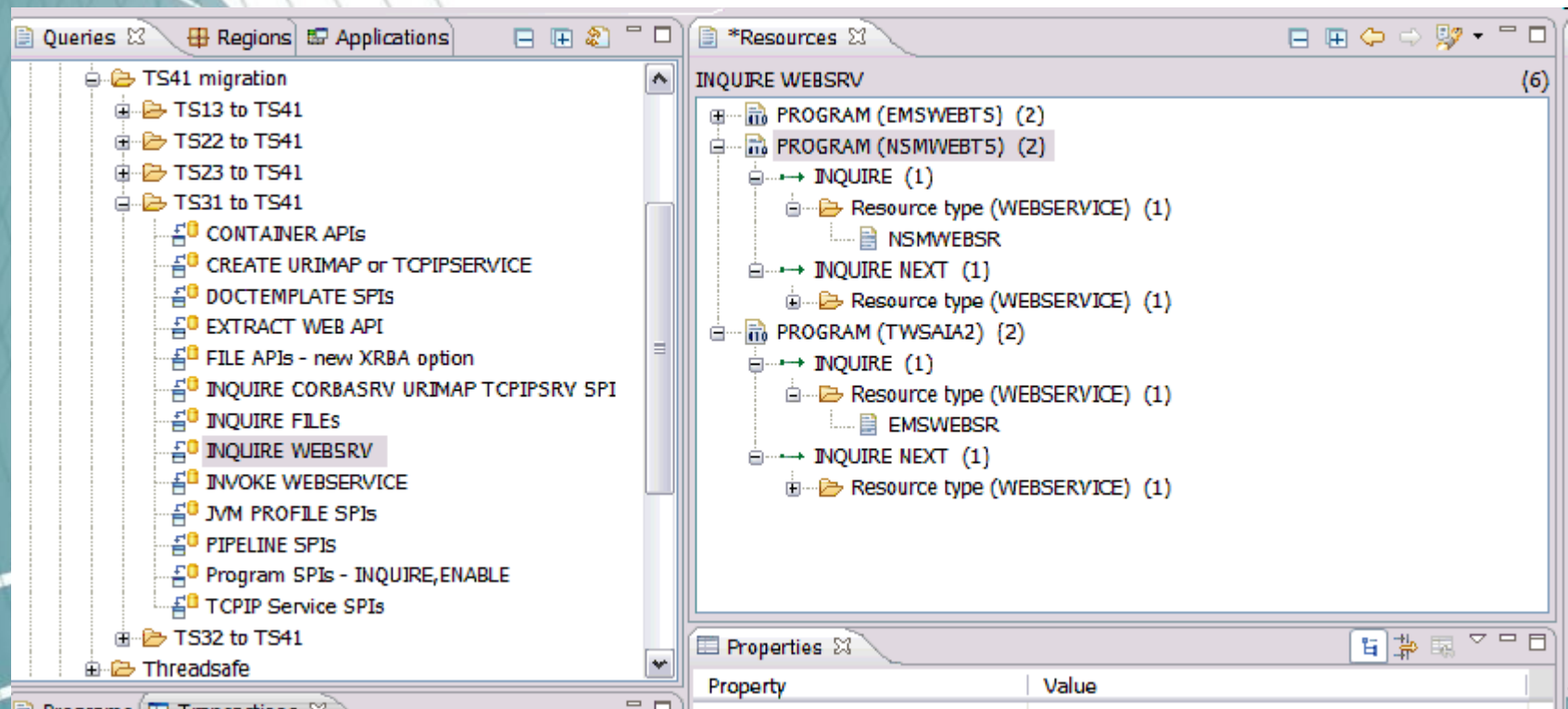

The screenshot displays the CICS Interdependency Analyzer interface. The left pane shows a tree view of migration categories, with 'INQUIRE WEBSRV' selected. The right pane shows a detailed view of the 'INQUIRE WEBSRV' resource, listing its dependencies on various programs and resource types.

| Property                   | Value |
|----------------------------|-------|
| PROGRAM (EMSWEBTS)         | (2)   |
| PROGRAM (NSMWEBTS)         | (2)   |
| INQUIRE                    | (1)   |
| Resource type (WEBSERVICE) | (1)   |
| NSMWEBSR                   |       |
| INQUIRE NEXT               | (1)   |
| Resource type (WEBSERVICE) | (1)   |
| PROGRAM (TWSAIA2)          | (2)   |
| INQUIRE                    | (1)   |
| Resource type (WEBSERVICE) | (1)   |
| EMSWEBSR                   |       |
| INQUIRE NEXT               | (1)   |
| Resource type (WEBSERVICE) | (1)   |

# Summary

- Installation
  - Similar to previous releases
  - Standard IBM procedure or DFHISTAR
- Upgrading
  - Application Programmers
    - Review Java programs and procedures
  - Systems Programmers
    - “Normal” release process
    - Review all GLUES, TRUES, URM's and Resource definitions





# Notes

- The installation of CICS TS V5.1 is similar to previous releases of the product.
- For systems programmers, the upgrade to CICS TS V5.1 is business as usual. All exits need to be reviewed for parameter list changes and thread safe applicability. Regions must be analyzed to determine if function removed in CICS TS V5.1 is being utilized and Independent Software Vendor (ISV) products must be review to determine the correct release levels required to support CICS TS V5.1
- Good luck in your efforts.