

 #SHAREorg

IMS Modernization – Advantages of Keeping Current with IMS Versions

Diane Goff
IBM IMS ATS

August 8, 2012
#11223



IMS Product General Focus Areas

- Support high transaction growth rates through performance, capacity and RAS enhancements
- Ease of administration and deployment, automation, reduce skill level
- Facilitate modernization of IMS applications, compliance, standards
- Base Enhancements
- Connectivity Enhancements

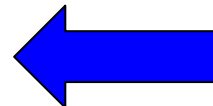

IMS Product Key New Function Focus

- Availability
- Reliability / serviceability
- Performance / capacity
- Ease of use / improved manageability

- SOA application integration, standards, compliance

- Base functions
- Connectivity functions

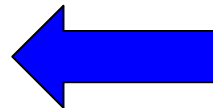

IMS Roadmap

- New major version every 2-3 years
 - IMS 10 GA Oct 2007
 - IMS 11 GA Oct 2009
 - **IMS 12 GA Oct 28, 2011**
 - IMS 12 + 1 in Development
 - IMS 12 + 2 in Planning
- Support
 - At GA Migration supports N-2
 - Typically two current supported field releases
 - N-2 release out of service 1 year after current release GA



Factors Driving IMS Modernization / Growth

- Global economy
 - Need for 7 X 24 X 365 availability
- Mergers and acquisitions
 - Flexibility to make changes
- Affordability of increasingly powerful technology
 - Cost-effectiveness
- Increased customer expectations for response times and availability
- Important that your IMS systems be ready to handle these new requirements

IMS Software Support Information

- IBM Software Support Handbook
 - <http://www14.software.ibm.com/webapp/set2/sas/f/handbook/home.html>
 - This guide contains important information on the procedures and practices followed in the service and support of your IBM products. It does not replace the contractual terms and conditions under which you acquired specific IBM Products or Services.
- IBM Software Lifecycle Support
 - http://www.ibm.com/software/support/lifecycle/index_a_z.html
 - The IBM Software Support Lifecycle policy specifies the length of time support will be available for IBM software from when the product is available for purchase to the time the product is no longer supported. IBM software customers can use this site to track how long their version and release of a particular IBM software product will be supported. Using the information on this site, customers will be able to effectively plan their software investment, without any gaps in support.

IMS Software Support Information

- End of Support (EOS) ...
 - Last date on which IBM will deliver standard support services for a given version/release of a product
 - Discontinuance of program service for the last release in a version of a software product is an indication of IBM's expectation that customers will not experience a high level of trouble due to program defects.
 - When service is discontinued, corrections to known problems remain available, but the development team is redirected to other work, and no new, tested corrections will be generated for general use.
 - Known problems may be reviewed and ordered via electronic vehicles such as the internet (e.g, <http://www.ibm.com/software/support>) however support provided by the IBM Client Support representatives, will be discontinued. At discontinuance of program service, associated services terminate as well, e.g. IBM Support Line and SoftwareXcel.

IMS Software Support Information

- End of Support (EOS)
 - Self-help Capabilities from the Internet
 - Basic search capability for the following:
 - *IBM software defects, that is, closed APARs (Authorized Program Analysis Report)*
 - *Software fixes*
 - *Technotes for resolved issues*
 - Provide notice of End of Support (EOS) at least twelve months before product support is withdrawn, giving you a reasonable period of time to use the software before migrating to a new version or release. Establish effective dates for withdrawal of product support in either April or September.
 - Support Extensions are accommodations for Customers who are unable to migrate to a supported software product release within the time provided.

IMS Version Service Support Information

IMS Version	Product Number	Available	Support Withdrawn (End of Support)
IMS 7	5655-B01	27 Oct 2000	08 Nov 2005
IMS 8	5655-C56	25 Oct 2002	05 Nov 2008
IMS 9	5655-J38	29 Oct 2004	07 Nov 2010
IMS 10	5635-A01	26 Oct 2007	05 Nov 2012 - NEW
IMS 11	5635-A02	30 Oct 2009	
IMS 12	5635-A03	28 Oct 2011	

Staying Current with IMS Versions

- Need for software support important in today's more dynamic high availability environments
- Each new version focuses on improving core functions of IMS (as well as connectivity)
- Core functions are key for flexibility to adapt to changes
- Many new functions are easy to implement
 - Minimal effort
 - Minimal ongoing costs
- Focus on mainframe qualities of service



IBM System z[®]

Think you know what a mainframe is?

An Old, Expensive platform for Legacy applications?

Think again! Today's IBM System z[®] is

- *The world's most trusted transaction processing and data server for business critical applications*
- *The world's most cost-efficient platform for data center consolidation and virtualization*
- *The worlds most dependable and scalable hardware and Middleware platform for new business applications*
- *A thoroughly modern application environment for traditional and Cloud delivery models*



Enterprise Modernization Makes Good Economic Sense



zEnterprise creates an agile, dynamic, and cost effective enterprise architecture and the modernization of existing assets helps to achieve Smarter Computing

- *Modernization to leverage your existing investments*
- *Reduce risk and complexity*
- *Increase efficiency with multiple platform development tools*
- *Design your enterprise processes for automation*
- *Gain real-time insight of the business*
- *Enable dynamic management of the business process*



Complete your sessions evaluation online at SHARE.org/AnaheimEval



2012

High Priority Recommendation for Modernizing Base (and Connectivity) IMS functions

- Implement the IMS Common Service Layer (CSL)
 - Available since IMS 8
 - Few enhancements in IMS 9
 - Many enhancements in IMS 10
 - More enhancements in IMS 11
 - More enhancements in IMS 12
- IMS architectural direction for implementing new functions, particularly in an IMSplex environment but also for single IMS standalone systems

IMS Common Service Layer Implementation

- Most new functions are based on CSL
 - Operations management (OM)
 - Resource management (RM)
 - Structured call interface (SCI)
 - Open database access (ODBM)
- Though available since IMS 8, IMS 10 / IMS 11 / IMS 12 provide many more interesting and useful functions
 - Will review these and others in this presentation
- Seriously consider implementing a minimal CSL (SCI/OM)
 - Called ***‘enhanced command environment’***
 - Most new functions require OM type-2 commands
 - Begin in test environment first
 - Overview and setup details for ***‘enhanced command environment’*** follow

Common Service Layer (CSL) Overview

- An architecture to improve the systems management capabilities for IMS systems
 - Operations management (Operations Manager)
 - Resource management (Resource Manager)
 - IMS Database access (Open Database Manager)
- Provides
 - A single system image (IMSplex)
 - Ease of use through a single point of control
 - Shared resources across all IMS systems
- Reduces complexity of managing multiple IMS systems and single IMS systems

Common Service Layer (CSL) Managers

- Operations Manager (OM) (IMS 8)
- Resource Manager (RM) (IMS 8)
- Structured Call Interface (SCI) (IMS 8)
- Open Database Manager (ODBM) (IMS 11)

- Based on BPE (Base Primitive Environment)
- Can use CQS (Common Queue Server)

- New address spaces
 - OM, RM, SCI, ODBM, CQS
- New CF structures (optional)
 - Resource, shared queues

CSL Architecture (Address Spaces and CF Structures)

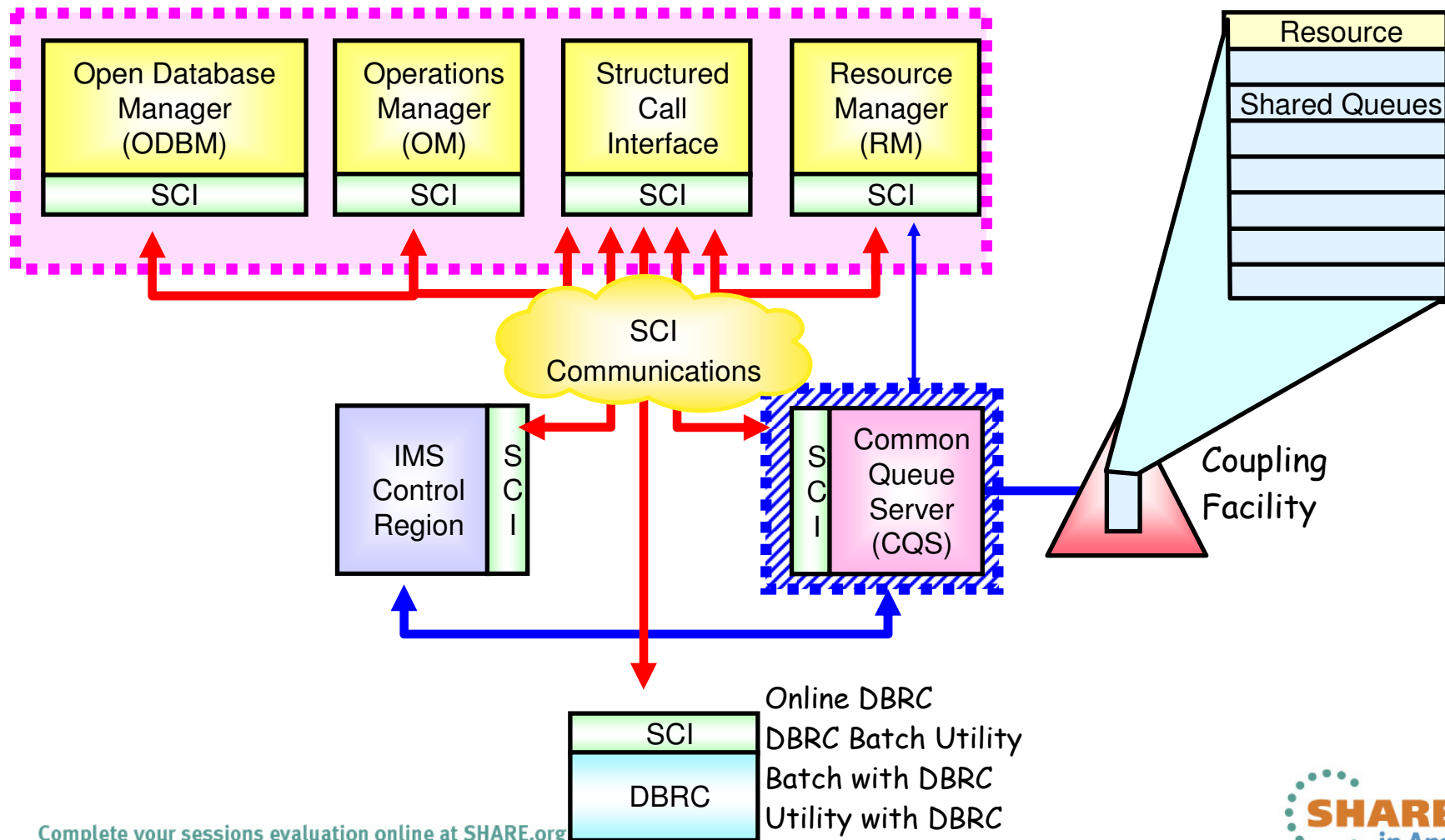

CSL Architecture (Address Spaces) – Enhanced Command Environment

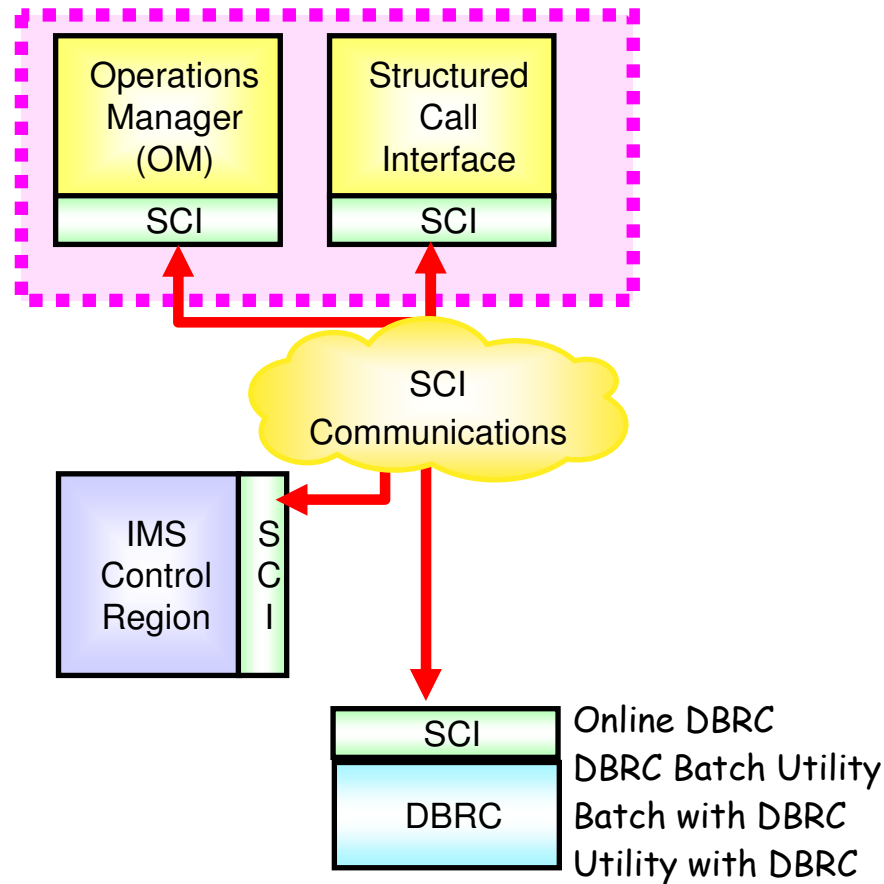

Operations Manager (OM) Overview

- Provides 'single point of control' for command entry into an IMSplex
 - Focal point for operations management and automation
- Provides the following services
 - Route commands to IMSplex members registered for the command
 - Consolidate command responses from individual IMSplex members into a single response to present to the command originator
 - Support for new IMSplex commands (type-2 commands) and for existing IMS commands (type-1 commands)
 - An API for IMS commands for automation
 - Command security for authorization using RACF or equivalent plus user exit
 - User exit capability for editing command input and responses
- Configuration
 - One or more OM address spaces required per IMSplex

Resource Manager (RM) Overview

- Provides infrastructure for managing global resources and IMSplex-wide processes
 - IMS is responsible for exploiting RM services
- Provides the following services
 - Maintains global resource information using a resource structure in a Coupling Facility
 - Coordinates IMSplex-wide processes
- Used for the following functions
 - Sysplex Terminal Management (STM) (IMS 8)
 - Global Online Change (GOLC) (IMS 8)
 - Global Callable Services (IMS 8)
 - Global Status (IMS 10)
 - Sysplex Serial Program Management (SSPM) (IMS 10)
 - ACBLIB Member Online Change (IMS 10)
 - Database Quiesce (IMS 11)
 - IMS Repository (IMS 12)

Structured Call Interface (SCI) Overview

- Provides communications services among IMSplex members in a single z/OS image and across multiple z/OS images in an IMSplex
- Provides the following services
 - Member registration services (security)
 - OM, RM, CQS, ODBM, IMS, SPOC, IMS Connect, DBRC
 - Communications services
- Used for the following functions that require DBRC SCI registration
 - Automatic RECON Loss Notification (ARLN) (IMS 8)
 - Parallel RECON Access (PRA) (IMS 10)
 - Database Quiesce (IMS 11)
- One SCI address space is required on each z/OS image where CSL is active

Open Database Manager (ODBM) Overview

- Supports open standards for distributed and local Java application program connectivity to IMS databases (IMS 11)
- Provides the following services
 - IMS Universal Drivers
 - Works with IMS Connect using DRDA for distributed access (type-4)
 - Works through DRA (Database Resource Adapter) interface for local access within a z/OS LPAR or across z/OS LPARs (type-2)
- Used for the following functions
 - Open Database (IMS 11)
- One ODBM address space is required on each z/OS image that contains databases to which ODBM clients (such as the IMS Universal Drivers) require access per IMSplex

CSL Architecture

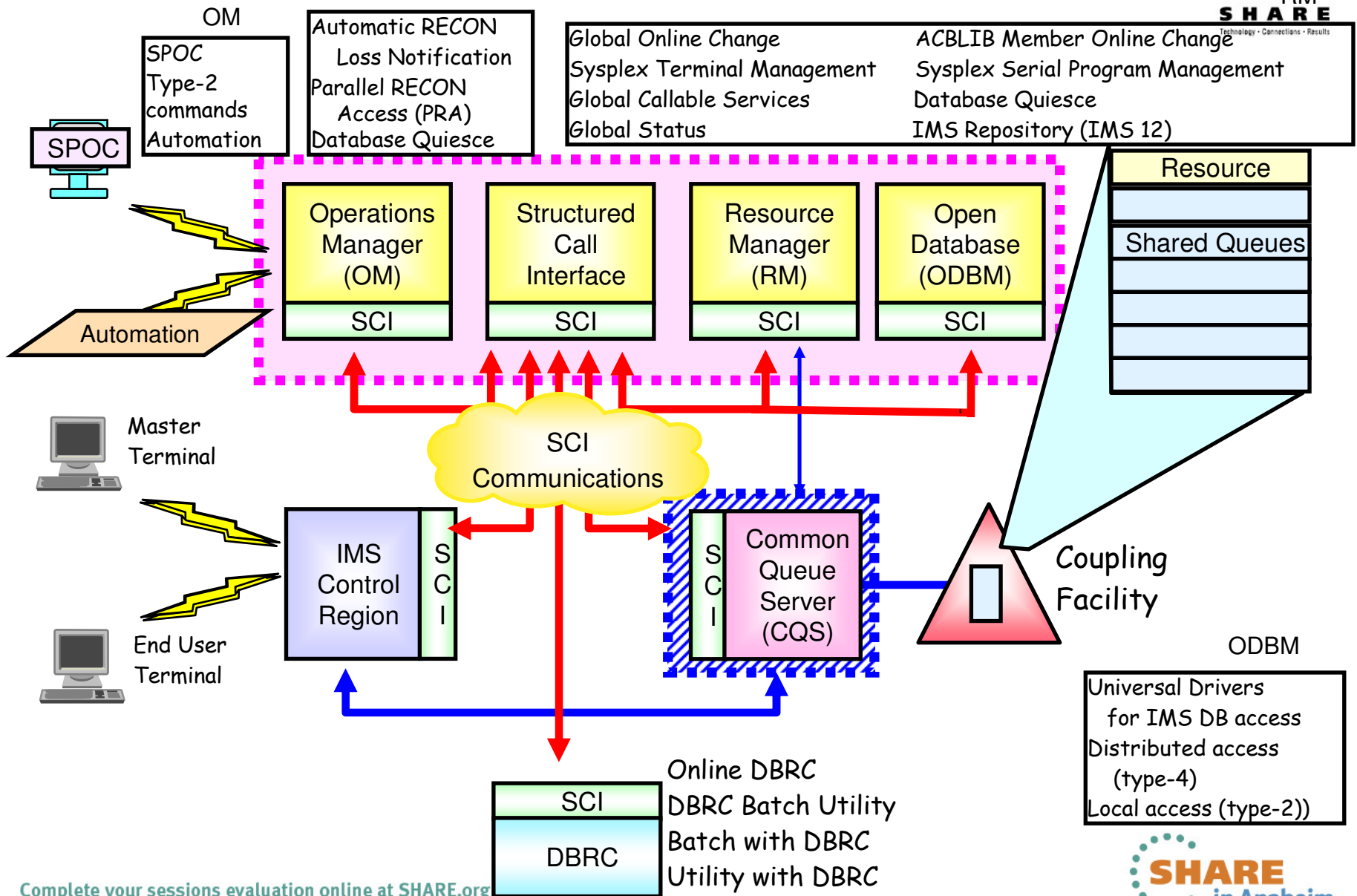

Complete your sessions evaluation online at SHARE.org

Setting up the CSL Environment

- BPE setup
- SCI setup
- OM setup
- RM setup
- ODBM setup
- CQS setup
- IMS setup
- z/OS / CF setup

Setting up the CSL Environment

– Enhanced Command Environment

- BPE setup
- SCI setup
- OM setup
- RM setup – N/A
- ODBM setup – N/A
- CQS setup – N/A
- IMS setup
- z/OS / CF setup – N/A

CSL Definition ... High Level View

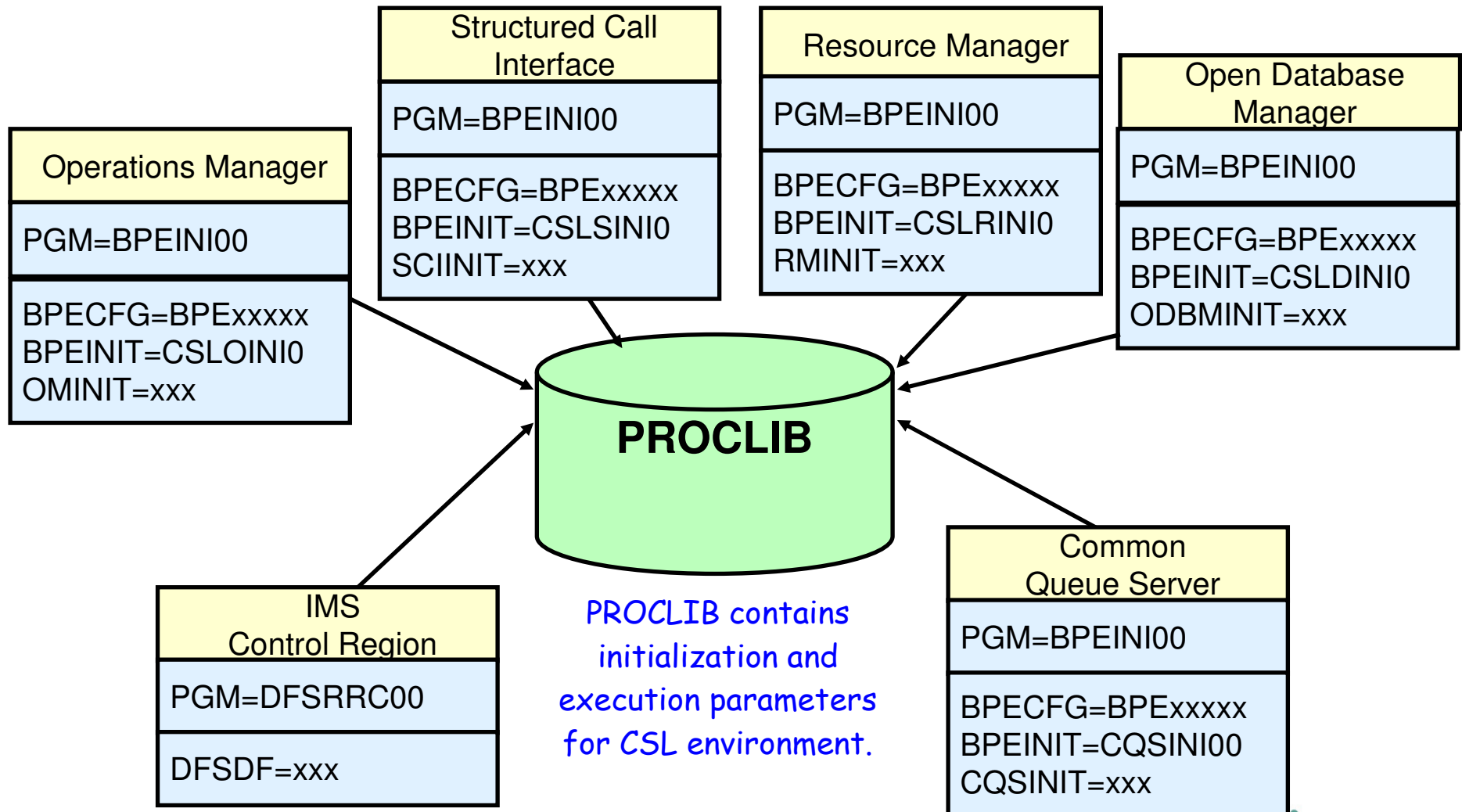

BPE Setup

- Add BPEINI00 to the z/OS Program Properties Table (PPT)
- Two BPE PROCLIB members
 - Contain trace level and user exit information
 - BPE Configuration Parameters (BPECFG=BPExxxxx)
 - BPE User Exit List
 - EXITMBR= in BPECFG=
 - *EXITDEF= in EXITMBR*
 - Neither are required
 - Can let BPE configuration parameters default
 - Do not need user exits
 - All IMSplex members can share the BPE PROCLIB members
- All CSL address spaces execute BPEINI00

Some CSL component setup rules

- All IMSplex members can share a PROCLIB
- Each CSL component type (OM, RM, SCI, ODBM) requires its own
 - Initialization module
 - BPEINIT = CSLxINI0 where x is O/R/S/D
- Each CSL component address space requires its own
 - Initialization PROCLIB member
 - xxxxINIT = yyy
 - where xxxx is OM/RM/SCI/ODBM
 - where yyy is a 3 character suffix used for the CSL initialization PROCLIB member CSLxlyyy
 - *where x is O/R/S/D and yyy is a 3 character suffix*

SCI setup

- One SCI address space is required on every z/OS image where CSL is active
- SCI started task JCL found in IMS.PROCLIB (CSLSCI)
- Each SCI address space
 - Executes BPEINI00
 - SCI initialization module
 - BPEINIT=CSLSINI0
 - SCI initialization PROCLIB member CSLSIxxx
 - SCIINIT=xxx
 - Each instance of SCI has a different initialization PROCLIB member to specify its unique SCI name (and IMSplex name)

OM Setup

- An OM address space is required on at least one z/OS image where CSL is active
 - Recommend a second OM for backup
- OM started task JCL found in IMS.PROCLIB (CSL \circ LOM)
- Each OM address space
 - Executes BPEINI00
 - OM initialization module
 - BPEINIT=CSL \circ INI0
 - OM initialization PROCLIB member CSL \circ Ixxx
 - \circ MINIT=xxx
 - Each instance of OM has a different initialization PROCLIB member to specify its unique OM name (and IMSplex name)

IMS Setup

- One new execution or DFSPBxxx parameter
 - Identifies DFSDFxxx
 - DFSDF=xxx
- One new PROCLIB member
 - DFSDFxxx
 - <SECTION=COMMON_SERVICE_LAYER>
 - <SECTION=DYNAMIC RESOURCES>
 - <SECTION=SHARED QUEUES>

IMS CSL Information

- IMS CSL presentations on IBM Techdocs website
 - <http://www.ibm.com/support/techdocs/atmastr.nsf/WebIndex/PRS3895>
 - IMS Common Service Layer Overview and Functions
 - Setting Up the IMS Common Service Layer

‘Base’ IMS Functions to Modernize IMS

- Availability
 - Reliability / serviceability
 - Performance / capacity
 - Ease of use / improved manageability
-
- Benefits
 - Installation complexity
 - On-going processor resources needed

Major Functions for Improving Availability ...

- Dynamic resource definition (DRD) (IMS 10)
 - Dynamic definition via type-2 commands for program/database/transaction/FP routing code resources
 - More quickly react to changes
- ACB library member online change (MOLC) (IMS 10)
 - Allows dynamic additions/changes of ACBLIB members while IMS is active via type-2 commands
 - Complements DRD for adding/changing ACBs for programs and databases

Major Functions for Improving Availability ...

- Global Status (IMS 10)
 - Maintains global command status for database, area, or transaction resources
 - Provides consistent status for these resources across restarts in an IMSplex
- Database quiesce (IMS 11)
 - Creates a coordinated recovery point via type-2 commands across an IMSplex for an IMS database or set of IMS databases within an IMSplex without taking databases offline
 - Reduces outages required for creating recovery points

Major Functions for Improving Availability ...

- Open Database (IMS 11)
 - Allows access to IMS DB from distributed and local environments for Java applications
 - DRDA protocols ease application development
- IMS repository (IMS 12)
 - Enables multiple IMS systems in an IMSplex to manage, store, share, and retrieve resource definitions in a centralized manner via type-2 commands
 - An alternative to using RDDs for DRD

Major Functions for Improving Availability

- IMS to IMS Replication (IMS 11)
 - **InfoSphere IMS Replication for z/OS V10.1 (5655-W28)** delivers a native IMS-to-IMS software replication solution that supports high-availability IMS data environments.
 - This solution synchronizes the contents of IMS databases on a single site, or across geographically dispersed locations, in near real time with full recovery.
 - When used with IBM management solutions, InfoSphere IMS Replication for z/OS supports a hot standby environment that can dramatically reduce the time to recovery for today's 24x7 processing environments.

Major Availability Improvements - some setup requirements



	Function	CSL	Setup	On-going resources
IMS 10	Dynamic resource definition (DRD)	Y	Medium	Low
IMS 10	ACB member online change	Y	Medium	Low
IMS 10	Global status for database, area, and transaction resources	Y	Medium	Low
IMS 11	Open database access to IMS DB	Y	High	Low-High
IMS 11	Database quiesce	Y	Low	Medium
IMS 12	IMS repository for DRD	Y	Medium	Low
IMS 11	IMS-to-IMS Replication	?	High	Low-High

Other Availability Improvements

- minimal / no setup requirements



	Function	CSL	Setup	On-going resources
IMS 9	HALDB Online Reorg		Low	Medium-High
IMS 10	Image Copy 2 Enhancements		Low	Medium-High
IMS 10	IRLM Lock Timeout Enhancement		Low	Low
IMS 10/11	OTMA descriptor / dynamic support	Y	Low	Low
IMS 11	Dynamic allocation of ACBLIB data sets		Low	Low
IMS 11	Dynamic allocation for OLCSTAT data set		Low	Low

Major Functions for Improving Reliability / Serviceability ...

- Transaction level statistics (IMS 10)
 - Improved log statistics for understanding transaction characteristics
- Timestamp precision for DBRC (IMS 10)
 - Microsecond precision to improve database integrity
- Operations Manager Audit Trail (IMS 10)
 - Improved auditability for OM environment
- BPE external trace to DASD (IMS 10)
 - Facilitates larger traces
- Dynamicabend dump formatting exit (IMS 11)
 - Installed during IMS startup

Major Functions for Improving Reliability / Serviceability

- U3310 abend and lock timeouts (IMS 12)
 - Additional diagnostics to resolve problem more quickly
- /DIAGNOSE SNAP command enhancements (IMS 12)
 - Improves problem diagnosis/resolution time

Reliability / Serviceability Improvements - some setup requirements



	Function	CSL	Setup	On-going resources
IMS 10	Operations Manager Audit Log	Y	Medium	Low
IMS 10	Transaction level statistics	Y	Low	Low-Medium

Reliability / Serviceability Improvements - minimal / no setup requirements ...



	Function	CSL	Setup	On-going resources
IMS 10	BPE external trace to DASD		Low	Low
IMS 10/11	IMS and IMS Connect support of RACF mixed case passwords		Medium	Low
IMS 11	Dump formatter enhancements		Low	Low
IMS 11	BPE-based DBRC		Low	Low
IMS 10	Analysis utilities rewrite		Low	Low
IMS 10	Timestamp precision for DBRC		Medium	Low

Reliability / Serviceability Improvements - minimal / no setup requirements



	Function	CSL	Setup	On-going resources
IMS 11	Dynamic abend dump formatting exit		Low	Low
IMS 12	/DIAGNOSE SNAP command enhancements		Low	Low
IMS 12	U3310 and lock timeouts		Low	Low
IMS 10/11/12	New tracing capabilities		Low	Low-High

Major Functions for Improving Performance / Capacity ...



- Parallel RECON access (IMS 10)
 - Improved technique for RECON serialization
- MSC Bandwidth (IMS 10)
 - Improved MSC buffer management
- FP 64-bit buffer manager (IMS 11)
 - Improved DEDB autonomic buffer management
- Dynamic full function database buffer pool enhancements (IMS 12)
 - Change OSAM/VSAM buffer pool specifications dynamically
- MSC TCP/IP support (IMS 12)
 - New type of physical MSC link that uses TCP/IP

Major Functions for Improving Performance / Capacity



- Logger enhancements (IMS 12)
 - Improvements for OLDS and WADS processing
- DRA thread enhancement with CICS 4.2 (IMS 12)
 - Eliminates overhead of TCB switching
- MIPS reduction enhancements (IMS 12)
 - Focus on internal/pathlength improvements
- zIIP enhancement for Shared Queues (IMS 12)
 - Request Response Processing eligible for zIIP processing

Performance / Capacity Benefits - some setup requirements



	Function	CSL	Setup	On-going resources
IMS 10	Parallel RECON Access	Y	High	Low-High
IMS 10	MSC Bandwidth	Y	Medium	Low
IMS 11	Fast Path 64-bit buffer manager for DEDBs	Y	Medium	Low-Medium
IMS 12	Dynamic full-function database buffer pool enhancements	Y	Low	Low-Medium
IMS 12	MSC TCP/IP support	Y	Medium	Low
IMS 12	Logger enhancements		Medium-High	Low
IMS 12	DRA thread enhancement with CICS 4.2		Low-Medium	Low

Complete your sessions evaluation online at SHARE.org/AnaheimEval



Performance / Capacity Benefits

- minimal / no setup requirements



	Function	CSL	Setup	On-going resources
IMS 10	Large sequential data set support		Low	Low
IMS 10	EAV support for VSAM data sets		Low	Low
IMS 10	OTMA transaction timeout enhancement		Low	Low
IMS 11	ACB 64-bit buffer pool	Y	Low	Low
IMS 11	IMS-managed JVM for dependent regions		Low	Low
IMS 12	EAV support for non-VSAM data sets		Low	Low
IMS 12	OTMA ACEE reduction enhancement		Low	Low
IMS 12	MIPS reduction enhancements		Low	Low
IMS 12	zIIP enhancement for Shared Queues		Low	Low

Complete your sessions evaluation online at SHARE.org/AnaheimEval



2012

Performance / Capacity Benefits

- minimal / no setup requirements



	Function	CSL	Setup	On-going resources
IMS 10/11/12	zAAP offload for IMS Java, SOAP Gateway, XML converter, IMS TM Resource Adapter zAAP on zIIP with z/OS 1.11		Low	Low-High
IMS 10/11/12	HALDB improvements	Y	Low	Low-Medium
IMS 10/11/12	VSCR relief		Low	Low-Medium

Major Functions for Ease of Use / Improved Manageability

- IMS Common Service Layer (IMS 9 / 10 / 11 / 12)
 - Improving operational characteristics and manageability
- Common security through RACF (SAF) interface (IMS 10)
 - Single point of administration
- Fast Path Secondary Index support (IMS 12)
 - New database design option
- IMS Explorer (IMS 11)
 - Simplifying application development
- IMS Catalog (IMS 12)
 - Simplifying data management

Ease of Use / Improved Manageability

- some setup requirements



	Function	CSL	Setup	On-going resources
IMS 9/10/11/12	Common Service Layer (CSL)	Y	Low	Low
	CSL Operations Manager (OM)	Y	Medium	Low
	CSL Resource Manager (RM)	Y	Medium	Low
	CSL Open Database Manager (ODBM)	Y	High	Low-High
IMS 10/11/12	Type-2 Command enhancements	Y	Medium	Low-Medium
IMS 10/11/12	Common security through RACF (SAF) interface		Medium	Low
IMS 12	Fast Path Secondary Index Support	Y	Medium	Low
IMS 11	IMS Explorer	Y	Medium	New capability
IMS 12	IMS Catalog	N	Medium	New capability

Complete your sessions evaluation online at SHARE.org/AnaheimEval



Ease of Use / Improved Manageability

- minimal / no setup requirements



	Function	CSL	Setup	On-going resources
IMS 10	DFSDFxxx PROCLIB member		Low	Low
IMS 10	Batch SPOC utility	Y	Low	Low-Medium
IMS 10	TSO SPOC print enhancements	Y	Low	Low
IMS 10	SSPM (Sysplex Serial Program Management) with shared queues		Low	Low-Medium

Ease of Use / Improved Manageability - various enhancements



	Function	CSL	Setup	On-going resources
IMS 10/11/12	DBRC Enhancements		Low-Medium	Low
IMS 10/11/12	IMS Connect enhancements	Y	Low-Medium	Low
IMS 10/11/12	OTMA enhancements		Low	Low
IMS 10/11/12	IMS Callout enhancements (synchronous / asynchronous)		Medium	Low-Medium

IMS Simplification Strategy

New IMS interfaces and models

IMS interfaces

IMS

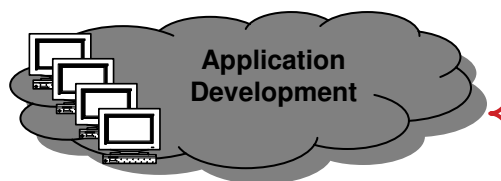
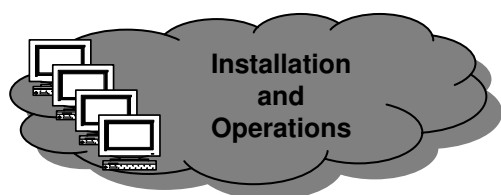

- SQL / JDBC
- IMS Tools
- Rational
- Optim
- Cognos
- InfoSphere
- J2EE
- pureQuery

- JCL
- ISPF
- SDSF
- JES
- User Mods
- User Exits
- DBDGEN
- PSBGEN
- ACBGEN
- OLC
- DRD
- DLI

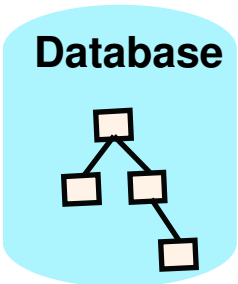

Reduce the need for special, in-depth IMS skills

Complete your sessions evaluation online at SHARE.org/AnaheimEval

IMS Explorer...Simplifying IMS application development !



Graphically-driven editors to display and update IMS program and database definitions

Graphical interface to easily access and manipulate IMS data using standard SQL

The screenshot shows the IMS Explorer interface. At the top, there are tabs for SQL scripts: *Script1.sql, *Script2.sql, *Script3.sql, and *Script5.sql. The main window displays a SQL query: `SELECT HOSPNAME, HOSPCODE, HOSPLL FROM PCB01.HOSPITAL`. Below the query editor, there are sections for 'HOSPITAL' (with checkboxes for HOSPCODE, HOSPLL, HOSPNAME), 'DISTINCT', 'Columns', 'Conditions', and 'Groups'. A 'Properties' and 'Execution Plan' section is also visible. The central part of the interface shows a graphical database schema diagram with tables like DEALER, MODEL, SALES, STOCK, SALESINF, SALESERP, SALESIMP, EMP, and EMPINFO, connected by lines representing relationships. At the bottom, a table shows the results of the query:

Status	Operation	Date	HOSPLL	HOSPCODE	HOSPNAME
✓	Succes select * from pcb...	8/2:	1	R 1210010000A	ALEXANDRIA
✓	Succes select * from pcb...	8/2:	2	R 1210020000A	SANTA TERESA
			3	R 1210030000A	SANTA CLARA
			4	R 1210040000A	NEW ENGLAND



Generate SQL to access IMS data

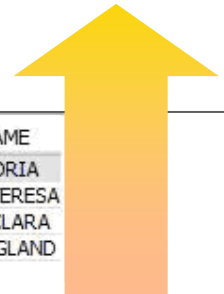

See database relationships
Change DBD and PSB definitions

Staying Current with IMS Versions is IMPORTANT!

- Need for software support important in today's more dynamic high availability environments
- Each new version focuses on improving base functions of IMS (as well as connectivity)
- Set up the IMS Common Service Layer (CSL)
- Base functions are key for flexibility to adapt to changes
- Many new functions are easy to implement
 - Minimal effort
 - Minimal ongoing costs
- Focus on mainframe qualities of service