

# IPv6 Basics

Share Orlando Session : 10397



Laura Knapp  
WW Business Consultant  
Laurak@aesclever.com

## What is IPv6

Updated version of the Internet Protocol (IPv4)

Defined in RFC 1752

New features

- Larger address space

- Encapsulation

- Class of service for audio, video, etc.

- Multicast support

- Authentication

- Encryption

- Automatic configuration/reconfiguration

- Support for non-IP protocols



**Coexist with IPv4**

## Why Do We Need More Address Spaces?

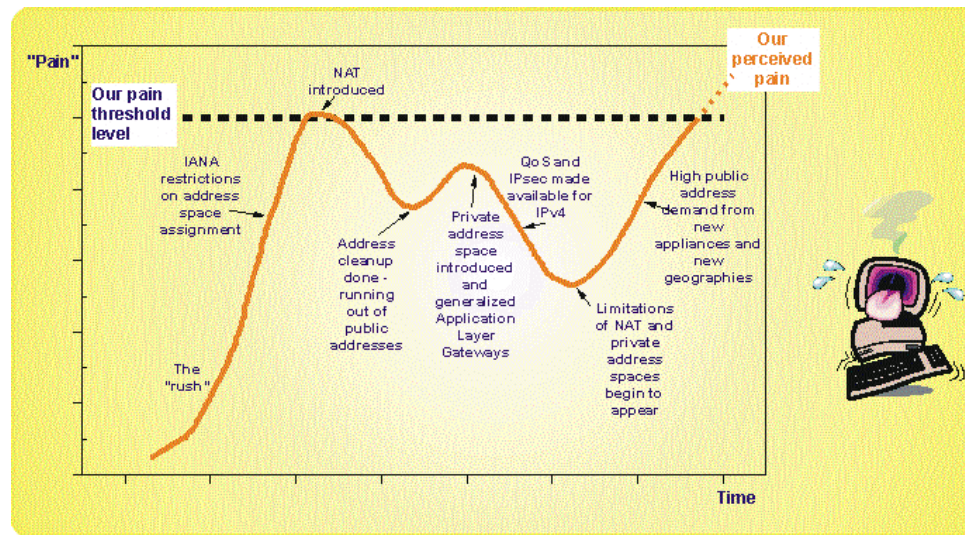

February 2011 – NRO (Number Resource Organization of the IANA) allocated the last IPv4 addresses to RIR

Microsoft paid \$7.5M for Nortels 666,624 IPv4 addresses

Trading sites like Tradipv4.com have emerged

# IPv4 address allocation by /8

Free /8

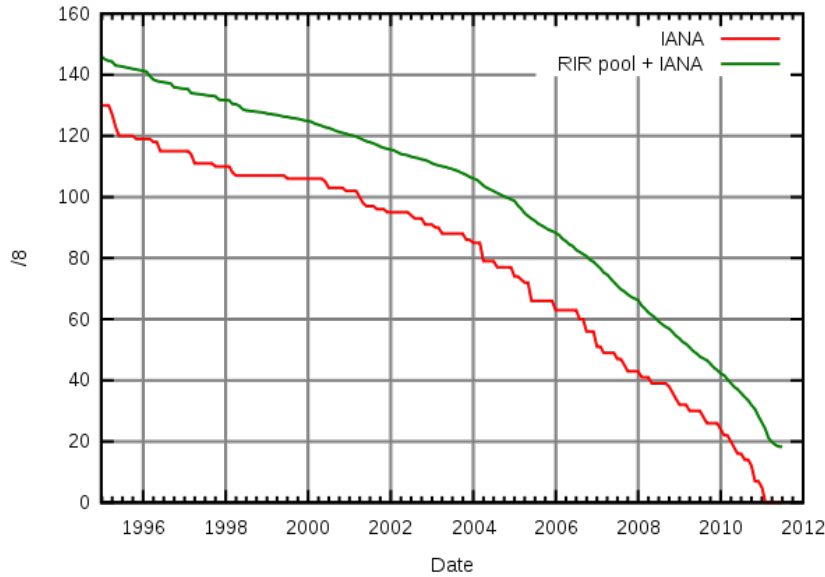

Daily assignment rate per RIR

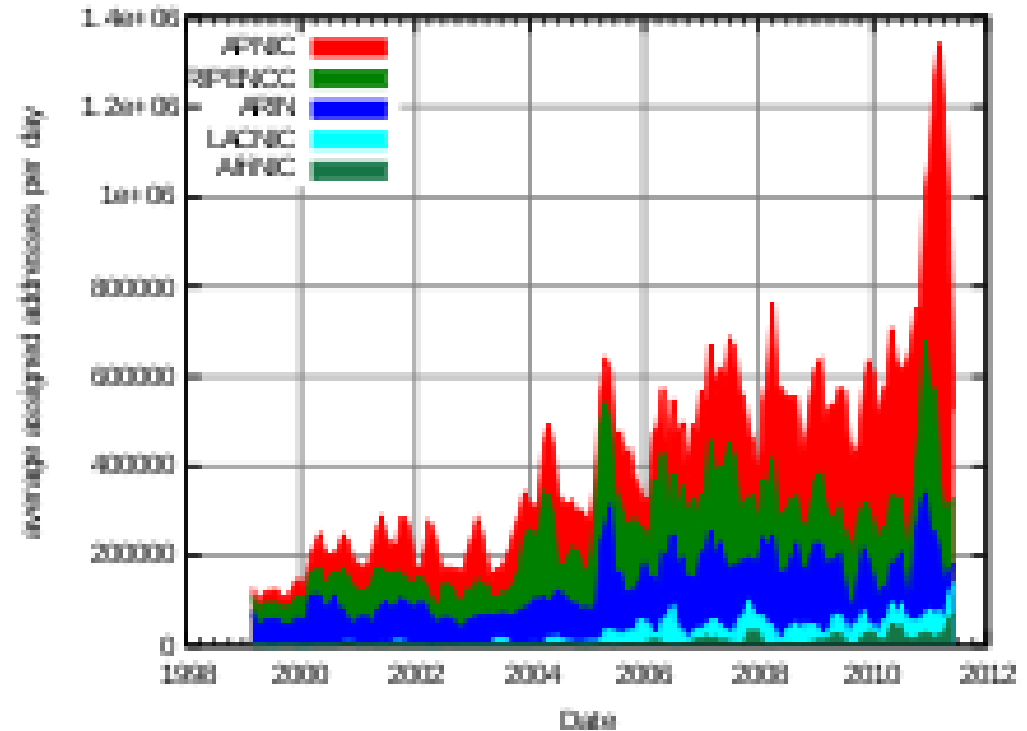

# Applications are Changing



# IPv6 Technology Scope

<i>IP Service</i>	<i>IPv4 Solution</i>	<i>IPv6 Solution</i>
Addressing Range	32-bit, Network Address Translation	128-bit, Multiple Scopes
Autoconfiguration	DHCP	Serverless, Reconfiguration, DHCP
Security	IPSec	IPSec Mandated, works End-to-End
Mobility	Mobile IP	Mobile IP with Direct Routing
Quality-of-Service	Differentiated Service, Integrated Service	Differentiated Service, Integrated Service
IP Multicast	IGMP/PIM/Multicast BGP	MLD/PIM/Multicast BGP, Scope Identifier

## Why IPv4 is not Sustainable Long Term

- **Trading smaller and smaller blocks will cause the global IPv4 routing table to explode.**
- **Small blocks make it difficult for large service providers to acquire enough space to sustain the business needs.**
- **The IPv4 address shortage will disproportionately harm the access providers relative to the content providers due to their imbalanced needs for additional addresses.**
- **If content providers require growth beyond the availability of IPv4, they can deploy IPv6, and then wait for the access providers to connect the content customers.**
- **Shortage driven IPv4 address block hijackings will become routine, which in turn will result in the routing table being politicized.**

## Parallel Connections Problems

- **Google Maps opens ~ 70 parallel connections**
- **iTunes store has been shown to open as many as 300 parallel connections**
- **IPv4/nat multiplexes multiple users through the port range, so 64k divided by 300 parallel connections results in ~200 customers per ISP based NAT address (assuming each customer is only allowed to run one simultaneous instance of iTunes or similar apps).**
- **Services generally don't allow connections from the same host to span multiple public side addresses, so use of more ports on another address will cause the application to fail.**
- **Reuse of port pairs can't be guaranteed with a high rate of churn in the port pool, so the likelihood of matching src/dst port pairs to popular sites will expose the probability of TCP sequence number overlap between unrelated connections.**



## IPv6 Address Size

207.217.125.50/24



IPv4  
(4 bytes - 32 bits)

2001:0DB8::15:219:D1FF:FE10:74EE/64

C L

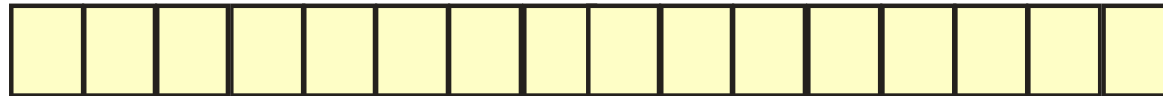

IPv6  
(16 bytes - 128 bits)

Asia feeling address squeeze fastest due to receiving addresses last

Mobil digital telephony pressuring existing IPv4 network

ICANN continues to handle overall addressing issues

Shortcuts like dropping **L** leading zeros or **C** ontiguous zeros permitte

# IPv6 Header

**IPv4 Header**

Vers: HD	TOS	Payload length
Fragment ID		Fragment Information
TTL	Protocol	Header Checksum
Source Address		
Destination Address		

**IPv6 Header**

Vers:Class	Flow Label	
Payload length	Next hdr	Hop limit
Source Address		
Destination Address		

**IPv4 header is 20 bytes : IPv6 header is 40 bytes**  
**Address increased from 32 to 128 bits**  
**Fragmentation fields moved out of base header**  
**Header checksum**  
**Time to Live replaced with 'Hop Limit'**  
**Protocol replaced with 'Next Header'**  
**TOS replaced with 'Flow Label'**  
**Alignment changed from 32 to 64 bits**

# IPv6 Flow Label

## IPv6 Header

Vers: TC	Flow Label	
Payload length	Next hdr	Hop limit
Source Address		
Destination Address		

Identifies datagrams that require special quality of service

May be used to tie particular traffic to pre-allocated network resources

Zero value indicates no flow label

Other protocols like RSVP may provide information for the Flow Label

TC class identifies delivery of priority packets  
 Values 0-7 : TCP flow controlled packets  
 Values 8-15 : real time packets

# IPv6 Extension Headers

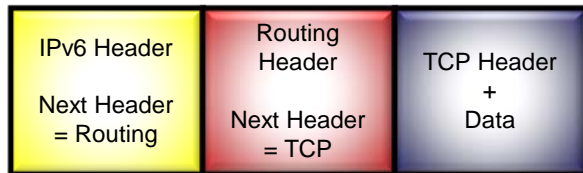
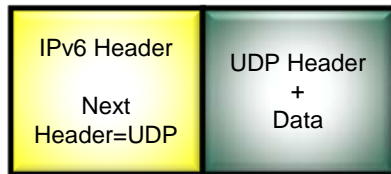
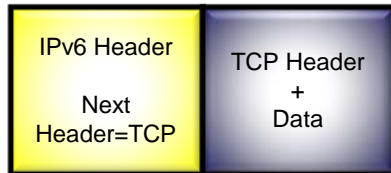

**Hop by hop options = 0**  
Information for all devices in the path

**Destination options = 60**  
Destination information for all devices

**Routing = 43**  
Specify route for a datagram

**Fragment = 44**  
Breaks datagram if MTU exceeded

**Encapsulating Security Payload = 50**  
Encryption type and parameters

**Authentication = 51**  
Hash type and parameters

**Destination options = 60**  
Information only for destination host

**Protocols**  
TCP = 6, UDP = 17, RSVP = 46, ICMP = 58

## IPv6 Fragmentation Header

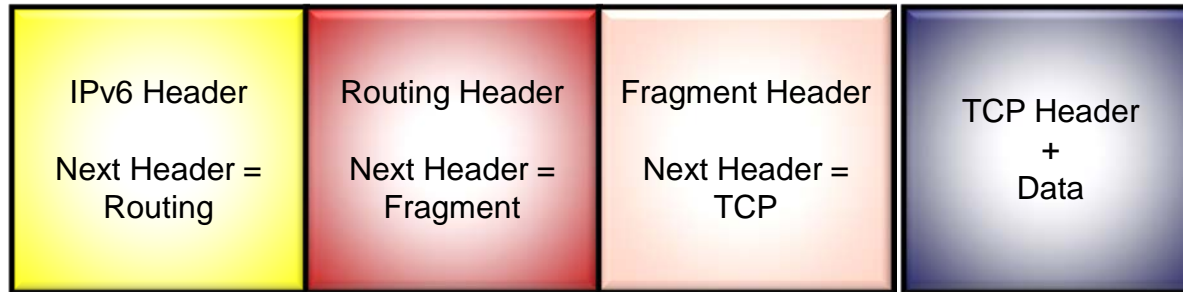

In IPv4 Routers handled fragmenting frames

If needed, IPv6 hosts fragment frames

Hosts use:

- Increased guaranteed minimum MTU of 1280

- Pat MTU discovery to find maximum fragment size for a path

## IPv6 Security

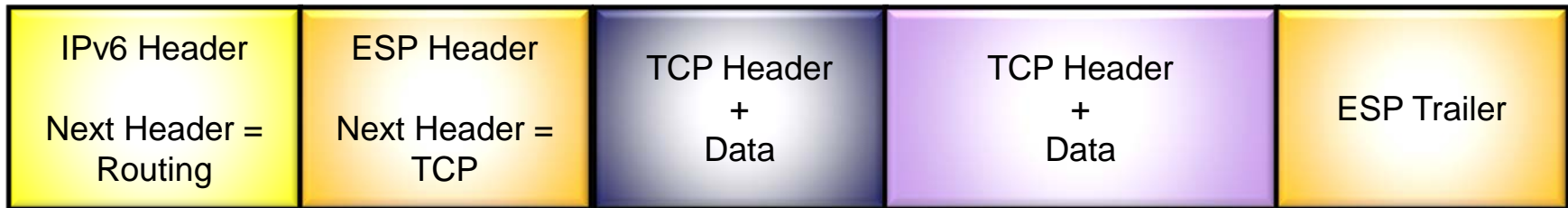

### Authentication Header (AH)

Packet authentication and integrity without confidentiality  
Algorithm independent (MD5) (SHA1)

### Data Privacy Header (ESP)

Message including next headers encrypted  
Mandatory support of DES-CBC  
May also include AH with no separate header

## IPv6 Address Types

unicast:

for one-to-one  
communication



multicast:

for one-to-many  
communication

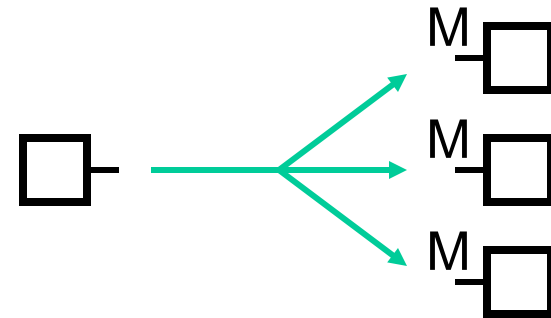

anycast:

for one-to-nearest  
communication

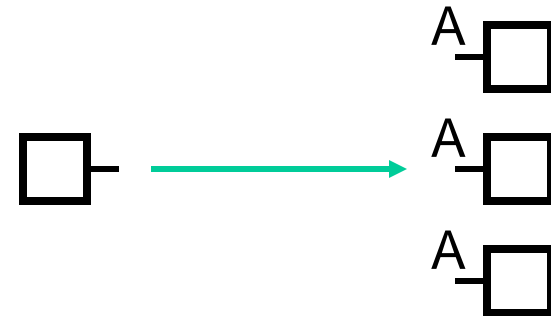

## IPv6 Address: Site and Link

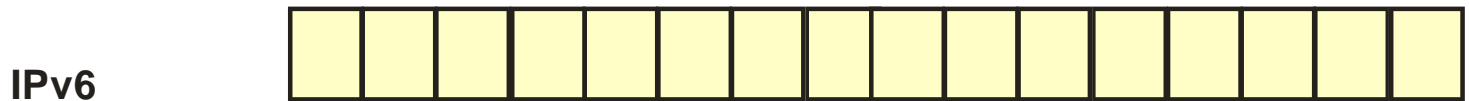

2001:0DB8::15:219:D1FF:FE10:74EE/64

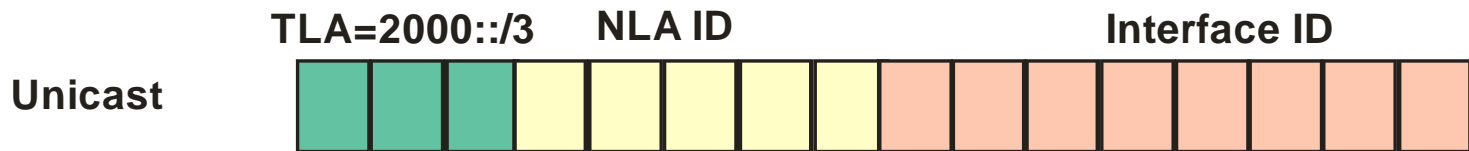
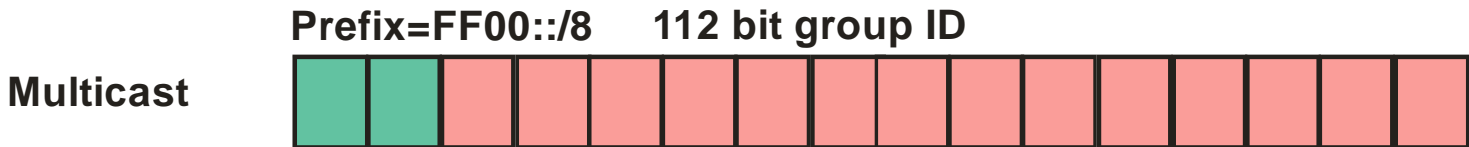

- 2001:0408/32    ATT
- 2001:0506:0000/48    Verizon Business
- 2001:4840/32    Earthlink
- 2001:49C0/32    IBM
- 2001:0200--039F    12 ISPs in Korea

FC00::/7 Unique Local – Internet router will discard  
 FE80::/10 Link Local – Non-routeable



## Global Unicast Address

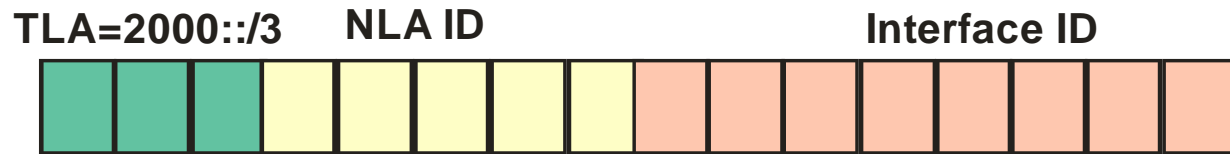

**TLA : Top Level Aggregation - 3 bytes (21 bits; First three bits of byte 1 are 001)**  
 IANA allocates address blocks to the regional Internet registries  
 They allocate portions of their block to national registries or to ISPs

**NLA : Next Level Aggregation - 5 bytes**  
 High order part assigned to smaller or regional ISPs, large companies  
 Holders of an NLA block assign parts of their block to their customers  
 They assign middle chunks to locations  
 Low order numbers identify subnets

**Interface ID : host interface (64 bits)**  
 Assigned by the owning organization  
 IEEE has defined a 64 bit NIC address known as EUI-64  
 NIC driver for IPv6 will convert 48 bit NIC to 64 bit NIC

**Structure greatly reduces the entries in the routing table....only one entry needed in a US router to define all the networks in a region or country**

# Interface ID from MAC

Company ID      Manufacturer Data



IEEE 48-Bit MAC Address



Expand to EUI-64

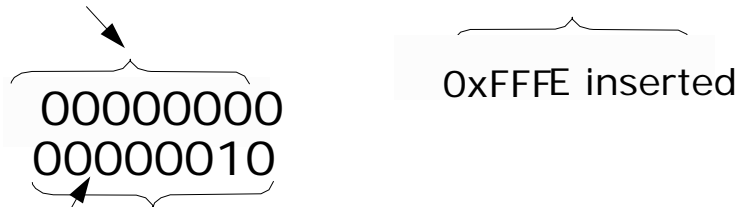

Invert the Global Bit

**0219:71FF:FE64:3F00**

Interface ID

# Boundaries

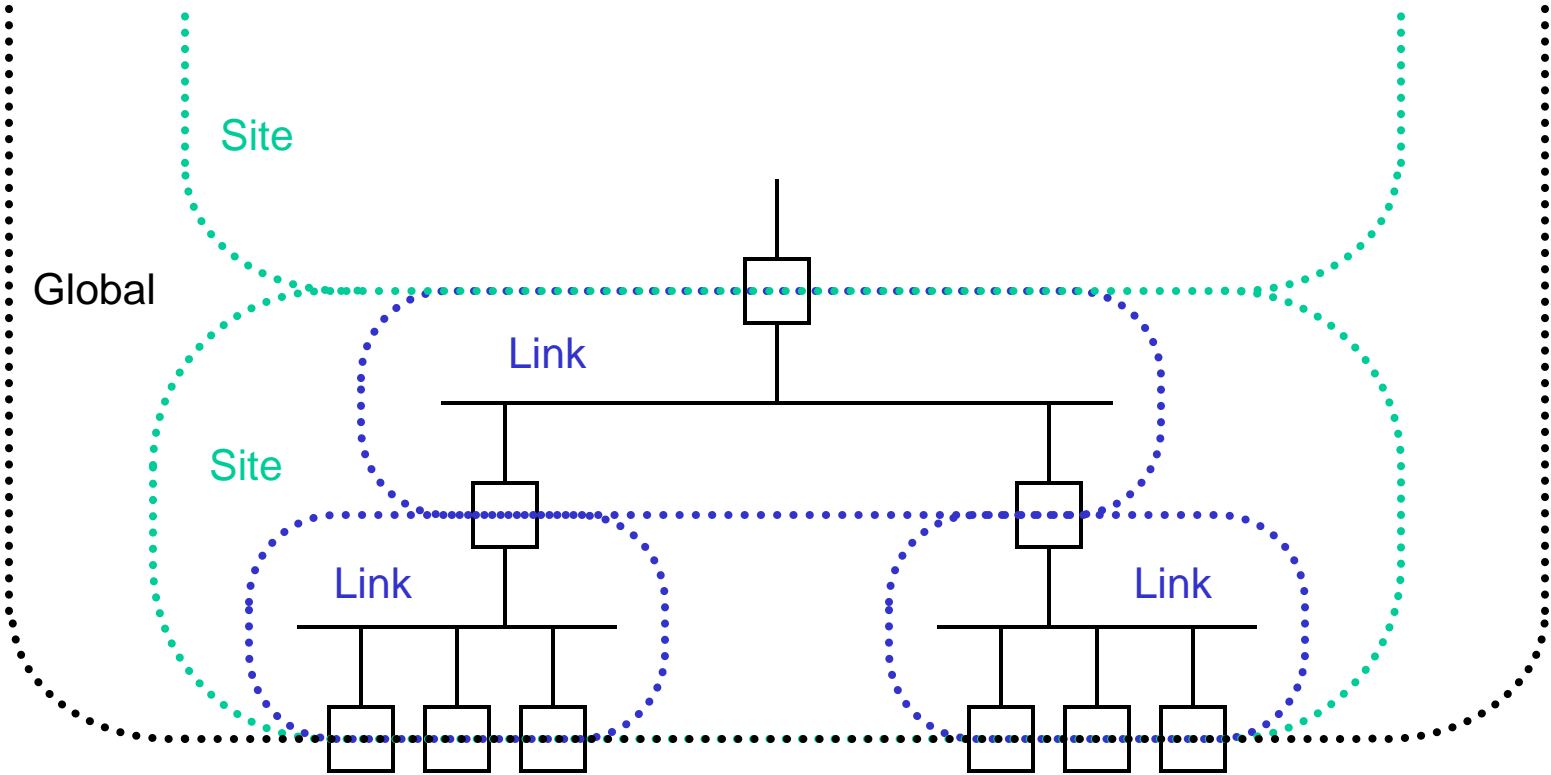

## IPv6: Autoconfiguration

### Combination

ARP : ICMP router discovery : ICMP redirect

### Neighbor discovery

Multicast and unicast datagrams

Establishes MAC address on same network

ICMPv6 router solicitation

ICMPv6 router advertisement

ICMPv6 neighbor solicitation

ICMPv6 redirect

ICMPv6 includes IGMP protocol for Multicast IP

Reduces impact of finding hosts

Stateless: router configures a host with IPv6 address

Stateful: DHCP for IPv6

Link Local Address: IPv6 connectivity on isolated LANs



## IPv6 Auto-configuration

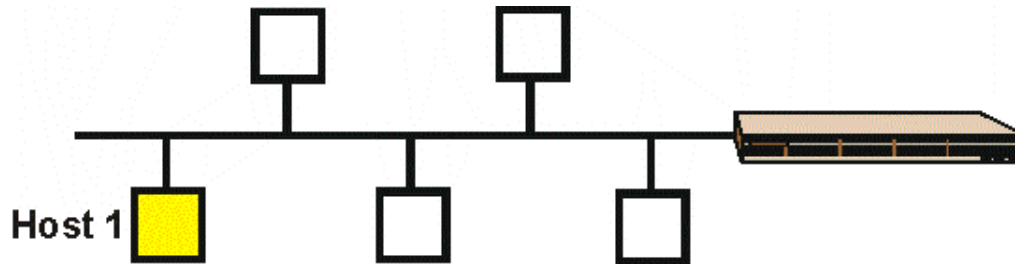

**Host 1 comes on line and generates a link local address**

**Host 1 sends out a query called neighbor discovery to the same address to verify uniqueness. If there is a positive response a random number generator is used to generate a new address**

**Host 1 multicasts a router solicitation message to all routers**

**Routers respond with a router advertisement that contains an aggregatable global address (AGA) prefix and other information**

**Host 1 automatically configures its global address by appending its interface ID to the AGA**

**Host 1 can now communicate**

# Changes Needed to Implement IPv6

## Hosts

Implement IPv6 code in operating system

TCP/UDP aware of IPv6

Sockets/Winsock library updates for IPv6

Domain Name Server updates for IPv6

## Domain Name Server (DNS)

Many products already support 128 bit addresses

Uses 'AAAA' records for IPv6

IP6.INT (in\_addr\_arpa in IPv4)

## Routers

IPv6 forwarding protocols

Routing protocols updated to support IPv6

Management needs to support ICMPv6

Implement transition mechanisms

## IPv6 Protocol Status

RIPv6 - Same as RIPv2

OSPFv6 - Updated for IPv6

EIGRP - Extensions implemented

IDRP - Recommended for exterior protocol over BGP4

BGP4+ - Preferred implementation in IPv6 today

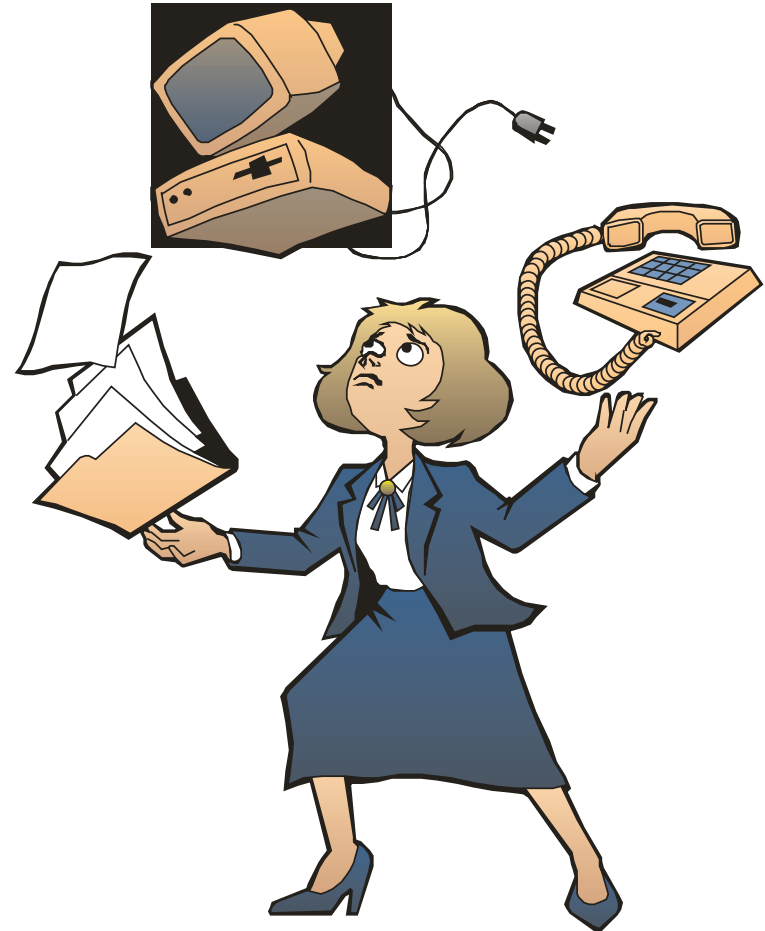

## Applications



NTT Technical Review

- NTT 'Earthquake Alert Service'
  - On detecting P-wave an S-wave alert is delivered
  - IPv6 Multicast is adopted
    - Low delay delivery is achieved
    - IPv4 is not suitable for a push-type service due to NAT
- Sensor Arrays
  - 6LoWPAN (RFC 4919 and 4944) based networks
  - Routing over low power and Lossy Networks
    - Sensors on aging infrastructure
    - Fire sensors
- Chinese Academy of Sciences
  - Integrated wireless, control and precision agriculture technologies linked
    - Accurate watering of farmland
    - Water/soil pollution monitoring

## NTT and IPv6



**1996:** NTT Labs started one of the world's largest global IPv6 research networks

**1998:** Verio begins participation in PAIX native IPv6 IX

**1999:** NTT Com begins IPv6 tunneling trial for Japanese customers

**2000:** Verio obtains IPv6 sTLA from ARIN

**2001:** NTT Com pioneers worlds first IPv6 connectivity services on a commercial basis

**2002:** World Communications Awards (WCA) awards NTT Communications with "Best Technology Foresight" for its IPv6 Global products

**2003:** NTT/VERIO launches IPv6 Native, Tunneling, and Dual Stack commercial service in North America

**2003:** Communications Solutions magazine names NTT/VERIO IPv6 Gateway Services "Product of the Year"

**2004:** NTT IPv6 Native and Dual Stack services available around the globe

**2004:** NTT Com wins the World Communications Awards "Best New Service" award for IPv6/IPv4 Global Dual Service

**2005:** Dual stack Virtual Private Server released. First ISP to offer an IPv6 managed firewall service

**10/2006 –** Launched the NTT Communications IPv6 Transition Consultancy

**2/2007 –** Awarded GSA Schedule 70 contract for IPv6 IP transit





## Global Crossing



- October 2005 IPv6 natively deployed
- End-to-end security, auto-configuration and mobile IP networking enable next generation of Internet services and applications.
- Meets enhanced requirements of government purveyors and systems integrators as they comply with federal mandates.
- IPv6 simplifies mobile IP networking with improved routing and security capabilities
- MPLS VPN is fully IPv6
- Ireland's national research network leverages the IPv6 network
- As a leading provider of IPv6 enablement, Global Crossing has been helping customers configure IPv6 across their networks for the past 10 years. As a sign of continuing commitment to successful IPv6 implementations, Global Crossing has dedicated its team of IPv6 experts to answering questions of enterprises in the process of IPv6 deployment. Interact with the Global Crossing team by:

## Comcast and IPv6

- 100 Million IP Addresses (doesn't include Digital voice/data)
- Exhausted NET 10 (RFC1918) for managing cable modems
  - This space exhausted in 2005
- In the control plane all devices need to be remotely managed so NAT is not an option
- Move to IPv6 will not happen overnight
  - Ask ARIN for address spaces every time they can justify it
  - Use already located non-globally routed IPv4 address space
  - Subdivide the network into independently managed domains...loss of global visibility
- Deployment Plans
  - Started in 2005
  - Start with control plane for the management and operation of edge devices
  - Dual stack t the core, IPv6 t the edges



## Google and IPv6



- <http://www.google.com/intl/en/ipv6/>
- **Access Google services over IPv6**
- At Google, we believe that IPv6 is essential to the continued health and openness of the Internet – and that by allowing all devices on a network to talk to each other directly, IPv6 will enable innovation and allow the Internet's continued growth. Typical Google users do not need to do anything to prepare for IPv6, but we are working with network operators to support the transition.
- In March 2008, we began offering Google search over IPv6 on IPv6-only websites like [ipv6.google.com](http://ipv6.google.com) (IPv6 connection required), but other Google products were not generally available over IPv6.
- That's why we created Google over IPv6. If you operate a network that supports IPv6, we may be able to enable Google over IPv6, letting you give users seamless access to most Google services over IPv6 simply by going to the same websites they usually use, such as [www.google.com](http://www.google.com).

## NTT/Verio IPv6 Backbone

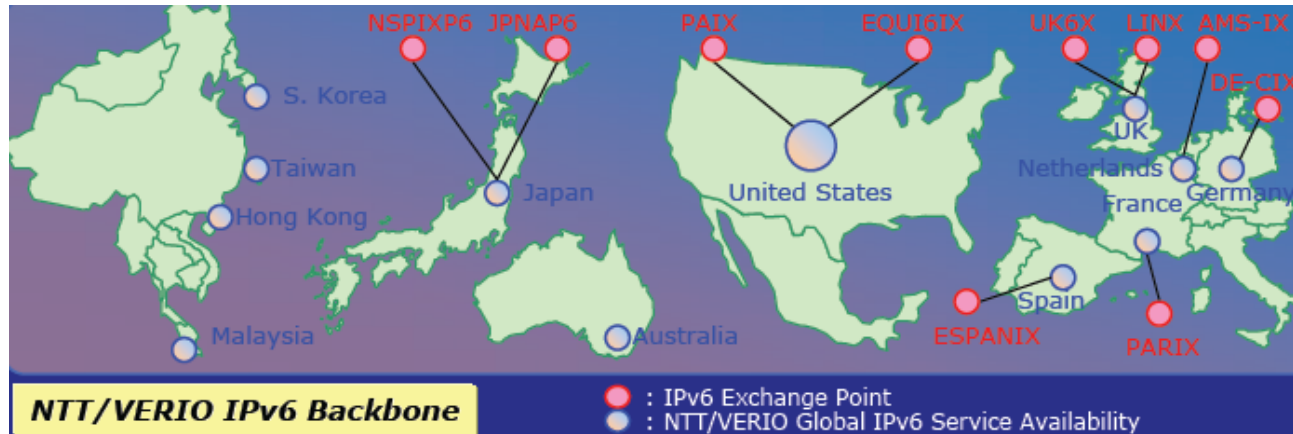

### Our Strength

- Global IPv6 networks covering Asia, Australia, the United States and Europe
- Providing commercial IPv6 transit services:
  - Since April 2001 in Japan
  - Since February 2003 in Europe
  - Since June 2003 in the United States and many of the Asia Pacific countries
- More than 3 years of operational experience
- 24x7 monitoring and operations by NTT/VERIO dual NOC in Japan and the United States
- Main IPv6-IX Connection:
  - Japan: NSPIX6, JPNAP6 (Tokyo)
  - United States: PAIX (West Coast), EQUI6IX (West Coast, East coast)
  - Europe: LINX, UK6X (London), AMS-IX (Amsterdam), PARIX (Paris), DE-CIX (Frankfurt), ESPANIX (Madrid)
- Optimal IPv6 routes

# IPv6 Day

The Internet Society is testing the availability and reachability of World IPv6 Day participants from our servers in the UK. The dials below indicate the percentages of participants announcing IPv6 DNS records, reachable from ISOC over IPv6, and reachable from ISOC over IPv4.

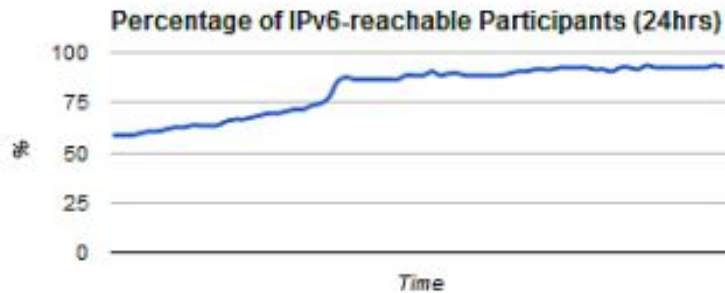

Last updated: Wed Jun 8 23:48:13 UTC 2011.

## IPv6 Transition Methods

### Tunneling

IPv6 only systems communicate across an IPv4 network

New “6to4” protocol from IETF

### Header translation

IPv6 system communicates with an IPv4 system

(header conversion, transport relay, application proxy)

### Dual Stack

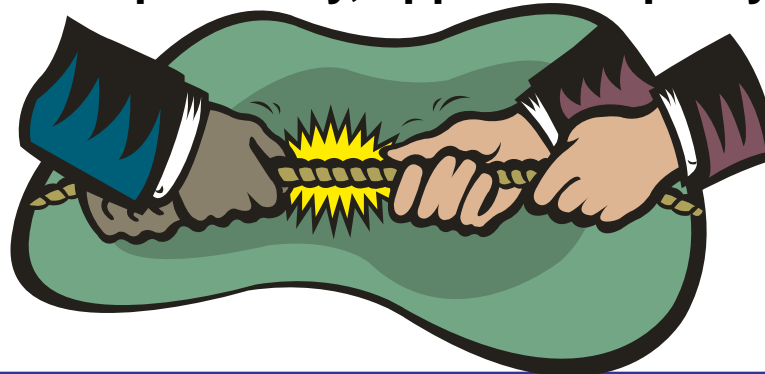

# IPv6 Transition Paths

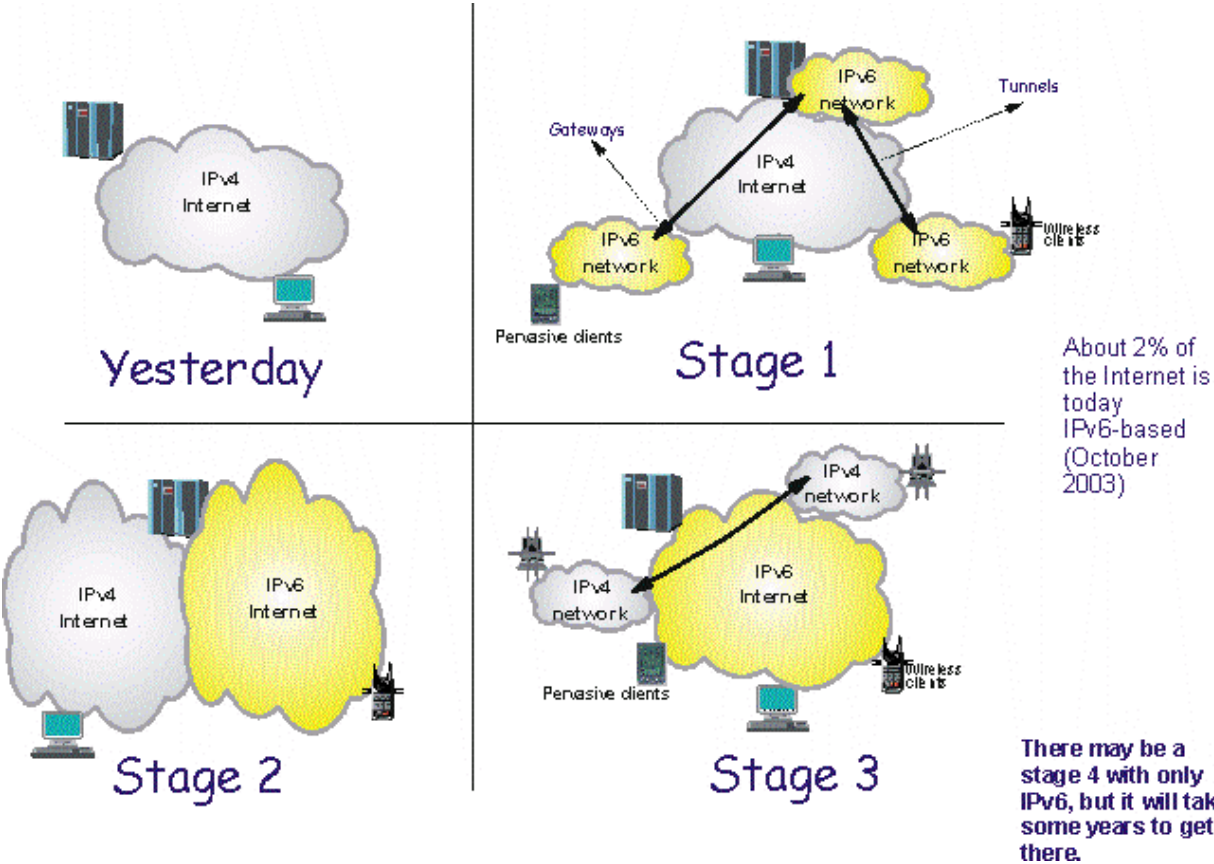

# Why IPv6 in Korea?

Prepare IPv4  
Address  
Depletion

- Usage ratio of assigned IP addresses : 96.2% (Mar. 2006)
- More IP addresses to be needed for the future IT839 Strategy

Promoting  
New  
Services

- IPv6 based Home Network Service
- IPv6 Service over 2.3 GHz based WiBro
- IPv6 based VoIP Service
- IPv6 based Telematics Service, and many others

IT839 New  
Growth  
Engine

- A master plan for the IT industry
- Effort to gain more growth momentum from the IT sectors



# IPv6 Transition Roadmap – Leading Korean ISP

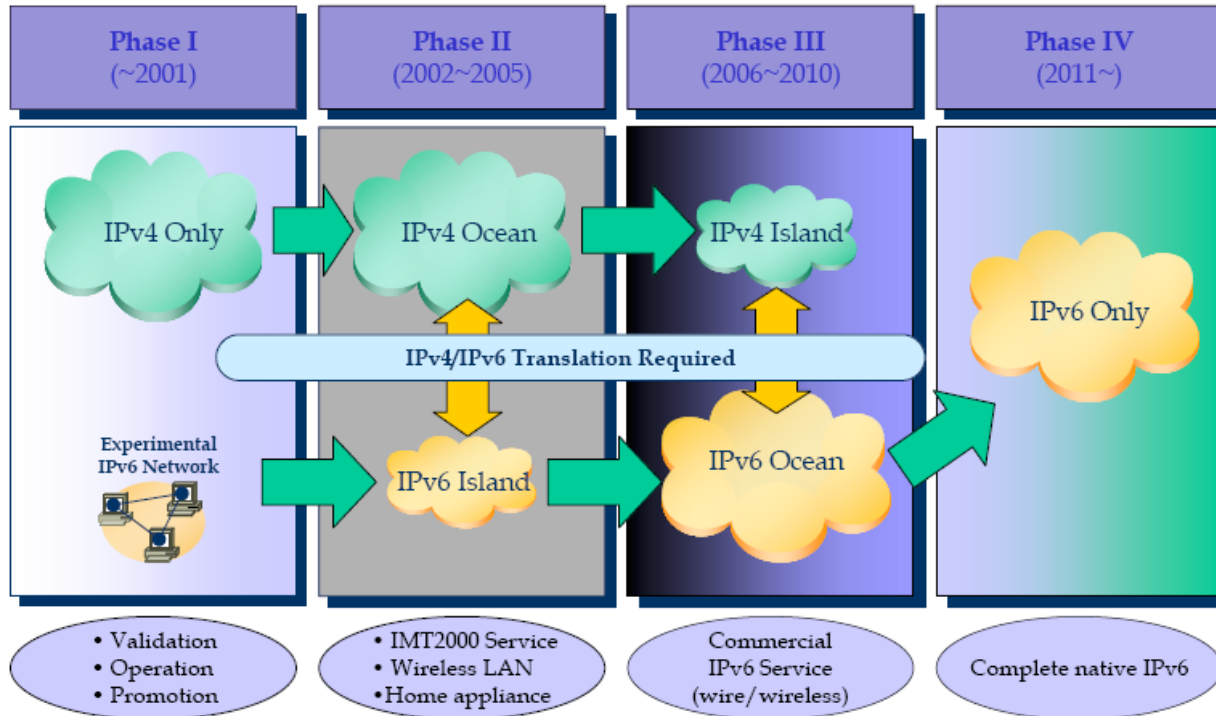

Expanded with country wide support services

6NGIX provides exchange among ISPs

Korea advanced Network providing IPv6 for organizations now

By end of 2009 3 new ISPs moving to IPv6 backbones

Public Sector transition planned for 2011

## 6to4 Tunneling

IPv6 traffic tunneled to go through an IPv4 network  
www.sixxs.net – Worldwide tunnel broker

Address - 2002:wwxx:yyzz::/48

wwxx:yyzz is both the NLA and the colon-hexadecimal representation of an IPv4 address assigned to the site or host

2002:wwxx:yyzz:[Subnet]:{Interface ID}

6to4 host - an IPv6 host that is configured with at least one 6to4 address

6to4 router - an IPv4/IPv6 router that forwards 6to4 traffic between 6to4 hosts within a site or 6to4 relay routers on the IPv4 Internet

6to4 relay router - an IPv4/IPv6 router that forwards 6to4 addressed traffic between 6to4 routers on the IPv4 Internet and hosts on IPv6 networks

**Anycast**  
**2002:C058:6301::**

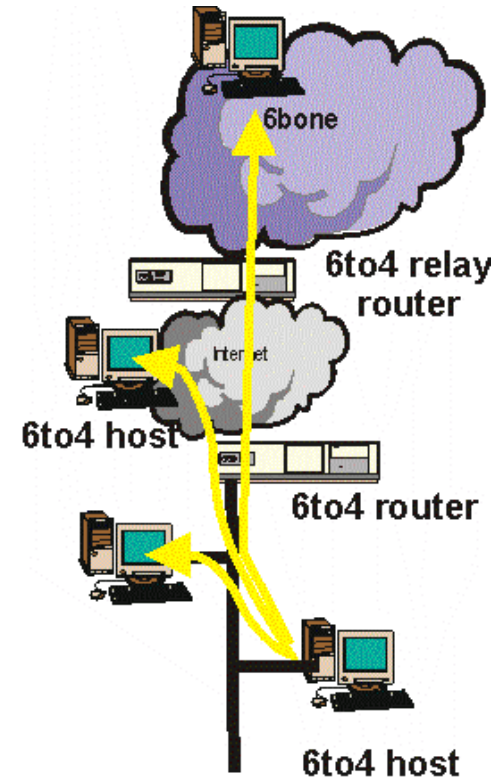

## Teredo

- 6to4 tunnels requires the tunnel end point public IPv4 address.....so for many that n NAT device...Many NAT devices cannot k upgraded
- Teredo encapsulates IPv6 in UDP/IPv4 datagrams.
  - Diagnoses UDP over IPv4 (UDPv4) connectivity and discovers the kind of NAT
  - assigns a globally-routable unique IPv6 address to each host using it;
  - encapsulates IPv6 packets inside UDPv4 datagrams for transmission over an IPv4 network (this includes [NAT traversal](#));
  - routes traffic between Teredo hosts and native (or otherwise non-Teredo) IPv6 hosts.

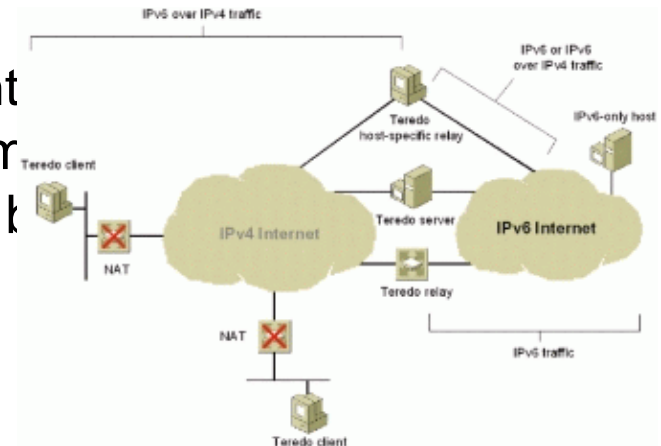

## IPv6 Translations

### **NAT-PT (Network Address Translation and Protocol Translation)**

Translates by mapping each IPv6 address onto one from a pool of IPv4 addresses

Upside: easy to implement and understand

Downside: Limits simultaneous access to multiple services with a network

Breaks end-end networking

Single point of failure

### **NAPT-PT (Network Address Translation plus Port Translation)**

Protocol gateway translates the IPv4/IPv6 network addresses and also maps port across boundaries

Upside: Easy to implement, adds support for more simultaneous sessions

Downside: Breaks end-end networking, single point of failure

### **SIIT (Stateless IP/ICMP Translation)**

IP packets and ICMP messages are translated between IPv4 and IPv6 with temporary assignments of IPv4 addresses creating a one-one mapping

Upside: Does not require state detail to be maintained

Downside: Does not save on IP addresses, single point of failure

## IPv6 Penetration Germany

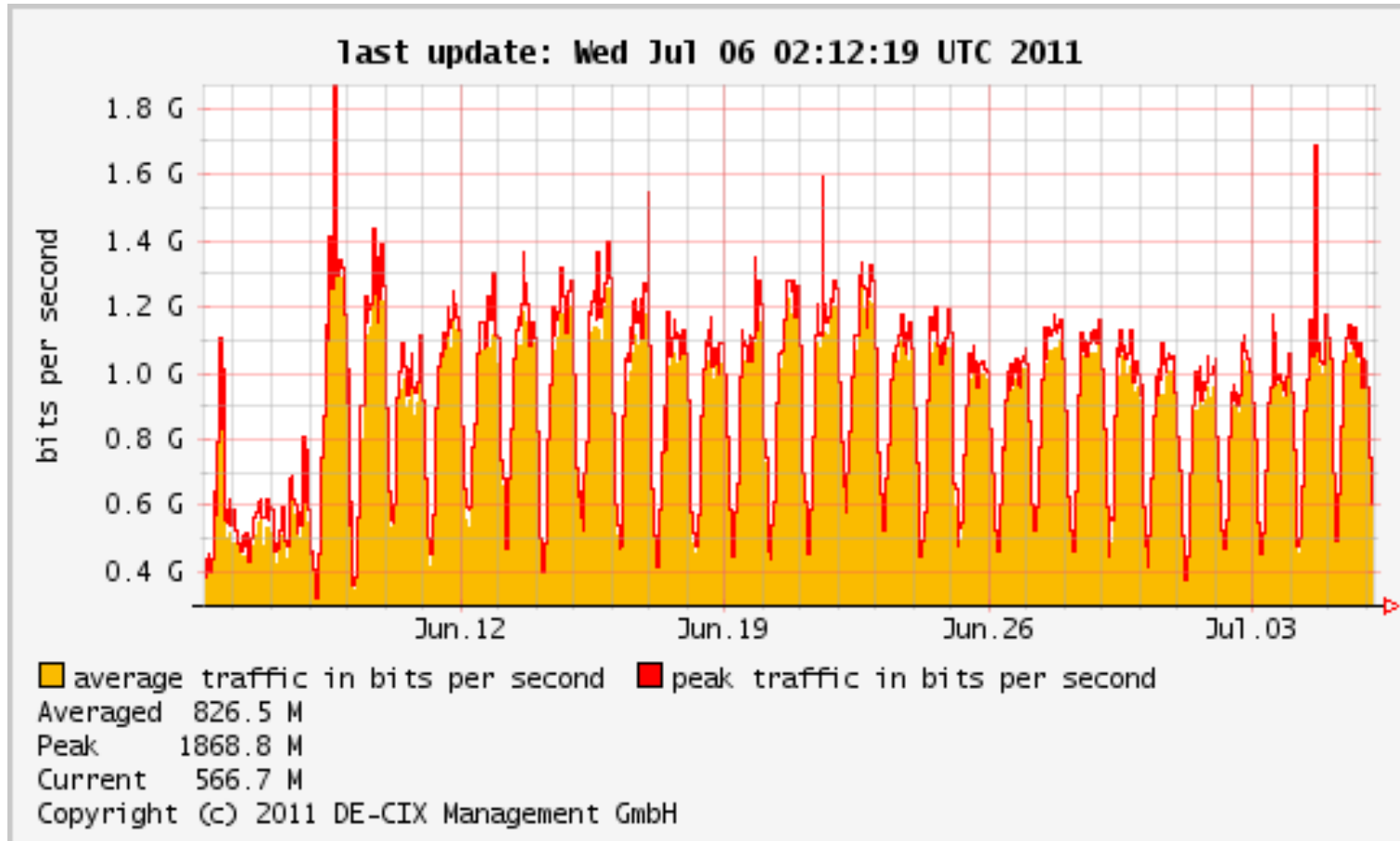

# Google IPv6 Statistics

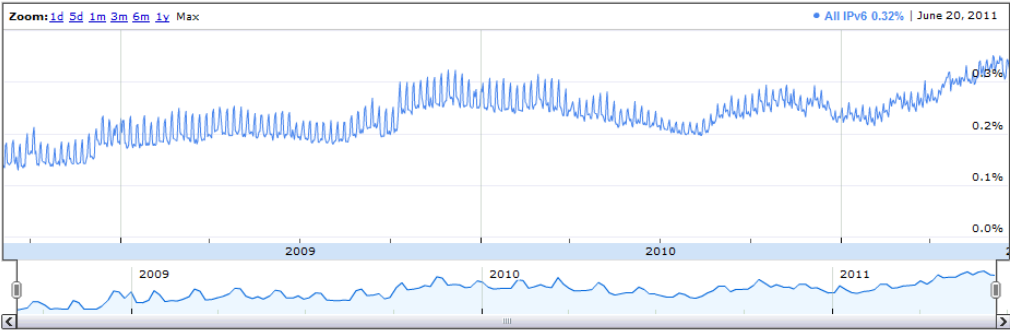

This is the Native IPv6 vs. 6to4/Teredo graph and shows what connectivity method is used by users. More connectivity is now native than before.

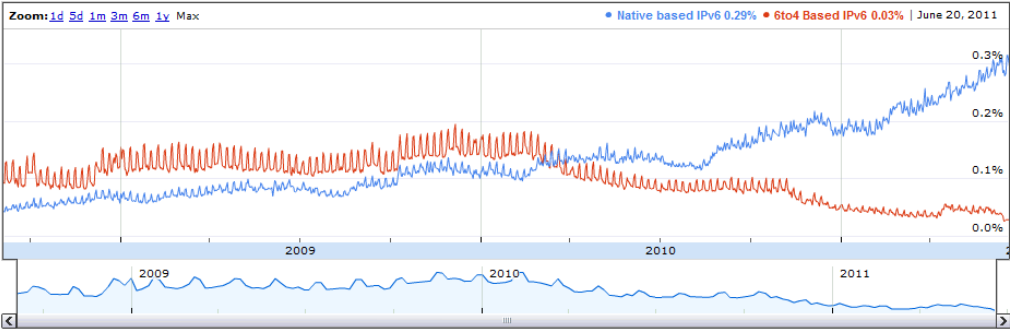

## IPv6 Migration Plans

**Define topology and functions on hosts, routers, and service machines**

**Upgrade DNS, DHCP, ARP servers to handle IPv6 addresses**

**Introduce dual stack systems that support IPv4 and IPv6**

**Configure to Internet using IPv6**

**Rely on tunnels to connect IPv6 islands separated by IPv4 networks**

**Gradually remove IPv4 from systems**

**Work closely with ISP for connections to the Internet**



## IPv6 References

<http://www.ietf.org/>

<http://playground.sun.com/pub/ipng/html/ipng-main.html>

[http://www.getipv6.info/index.php/IPv6\\_Presentations\\_and\\_Documents](http://www.getipv6.info/index.php/IPv6_Presentations_and_Documents)<http://www.6ren.net>

<http://www.ipv6forum.com>

<http://arin.net>

<http://www.internet2.edu>

<http://www.ipv6.org>

<http://ipv6.or.kr/english/natpt.overview>

<http://www.research.microsoft.com/msripv6>

<http://www.ipv6.org.uk>

New Internet Protocol - Prentice Hall - ISBN 0-13-241936-x

IPNG and the TCP/IP Protocols - John Wiley and Sons - ISBN-0-471-13088-5

IPv6 The New Internet Protocol - ISBN-0-13-24-241936

IPNG Internet Protocol Next Generation - ISBN-0-201-63395-7

Internetworking IPv6 with Cisco Routers - ISBN 0-07-022831-1





## AES Sessions at Share

Mar 12, 2012: 1:30-2:30 10715: [Keeping Your Network at Peak Performance as You Virtualize the Data Center](#)

Mar 14, 2012: 8:00-9:00 10397: [IPv6 Basics](#)

Mar 14 2012: 1:30-2:30 10395: [IPv6 Tunneling Technologies](#)

Mar 14, 2011: 1:30-2:30 10720: [Network Problem Diagnosis with OSA Examples](#)

Mar 15, 2012: 3:00-4:00 10401: [IPv6 Performance Management](#)

Mar 16, 2012 9:30-10:30 10393: [CSI Maui: The Case of the Compromised Server](#)

Mar 16 2012 11:00-12:00 10414 [IPv6 Transitioning](#)

*Vielen*  
**Dank**

*Köszönettel*

# QUESTIONS?

*Obi* Спасибо

**Bedankt**

ขอบคุณ

شكراً

**Gracias**

Ευχαριστώ

*Merci*

*Díky*

شكراً

धन्यवाद

**THANK YOU**

Grazie

Danke

*Hvala*

ขอบคุณ

תודה

ありがとうございました

Merci

Teşekkürler

धन्यवाद  
Hindi  
**Gracias**

[laurak@aesclever.com](mailto:laurak@aesclever.com)

감사합니다

[www.aesclever.com](http://www.aesclever.com)

நன்றி  
Tamil

**650-617-2400**

Obrigado